

THE
JOURNAL OF ECONOMIC BIOLOGY

EDITED BY

WALTER E. COLLINGE, M.Sc., F.L.S., F.E.S.,

*Foreign Member of the Association of Economic Entomologists, Washington, U.S.A.;
Honorary Secretary of the Association of Economic Biologists; Honorary
Consulting Zoologist to the Land Agents' Society, and the Midland
Reafforesting Association; and Special Lecturer on Economic
Zoology in the University of Birmingham.*

WITH THE CO-OPERATION OF

A. H. REGINALD BULLER, D.Sc., Ph.D.,

Professor of Botany in the University of Manitoba, Winnipeg.

GEO. H. CARPENTER, B.Sc., M.R.I.A.,

*Professor of Zoology in the Royal College of Science for Ireland,
and Consulting Entomologist to the Royal Dublin Society.*

ROBERT NEWSTEAD, A.L.S., F.E.S.,

*Lecturer in Entomology and Parasitology in the Liverpool School of Tropical Medicine,
and Hon. Lecturer on Economic Entomology in the University of Liverpool.*

AND

A. E. SHIPLEY, M.A., F.R.S.,

*Fellow and Tutor of Christ's College, Cambridge, and University
Lecturer in Advanced Morphology of the Invertebrata,*

VOLUME II.

1907-8.

LONDON:

DULAU AND Co., 37, SOHO SQUARE, W.

1908.

CONTENTS OF VOLUME II.

	PAGE
The Spruce-Gall and Larch-blight diseases caused by <i>Chermes</i> , and suggestions for their prevention. By E. R. BURDON, M.A., F.L.S. (Figures A and B)	I
New Hemipterous Fruit Pests in Britain. By FRED. V. THEOBALD, M.A. (Plates i and ii.)	14
Hints on the Collecting of Timber Specimens. By HERBERT STONE, F.L.S., F.R.C.I. (Plates iii and iv.)	26
Brandis' Indian Trees. By Prof. W. R. FISHER, M.A.	32
Reviews and Current Literature.	35
Parthenogenesis in <i>Lophyrus pini</i> . By R. STEWART MACDOUGALL, M.A., D.Sc., F.R.S.E. (Plate v.)	49
On the Life-history of the Root-Maggot, <i>Anthomyia radicum</i> , Meigen. By C. GORDON HEWITT, M.Sc. (Plate vi.)	56
A Remedy for the Spruce Gall and Larch Blight Diseases caused by <i>Chermes</i> . By E. R. BURDON, M.A., F.L.S.	64
Reviews and Current Literature.	68
On the Bionomics of certain Calyptrate <i>Muscidae</i> and their Economic significance, with especial reference to Flies inhabiting houses. By C. GORDON HEWITT, M.Sc.	79
Notes on Ticks. By CECIL WARBURTON, M.A., F.Z.S. (Plate vii.)	89
The Application of Economic Biology to Agriculture. By WALTER E. COLLINGE, M.Sc., F.E.S.	96

iv.

	PAGE
Reviews and Current Literature.	107
Some Critical Observations on the European species of the Genus <i>Chermes</i> . By E. R. BURDON, M.A., F.L.S. (Plates viii and ix.)	119
On the Structural Characters of Three Species of <i>Coccidae</i> affecting Cocoa, Rubber, and other plants in Western Africa. By ROBERT NEWSTEAD, A.L.S., etc. (Figures A—C.)	149
Reviews and Current Literature.	158

LIST OF ILLUSTRATIONS IN VOLUME II.

	PAGE
Development of healthy Spruce shoot.	8
Development of Spruce shoot attacked by <i>Chermes</i>	8
New Hemipterous Fruit Pests. Plates I and II.	24
Sections, etc., of Wood of <i>Stenocarpus</i> . Plate III.	30
Sections, etc., of Wood of <i>Myrsine</i> . Plate IV.	30
<i>Lophyrus pini</i> , Curtis. Plate V.	55
<i>Anthomyia radicum</i> . Plate VI.	63
Diagrams of <i>Ixodidae</i> . Plate VII.	95
European Species of <i>Chermes</i> . Plates VIII and IX.	148
Structural Characters of <i>Stictococcus sjöstedti</i> , Ckll.	152
Structural Characters of <i>Palaeococcus theobromae</i> , n. sp.	154
Structural Characters of <i>Pulvinaria jacksoni</i> , n. sp.	156

THE
JOURNAL OF ECONOMIC BIOLOGY.

THE SPRUCE-GALL AND LARCH-BLIGHT DISEASES CAUSED
BY CHERMES, AND SUGGESTIONS FOR THEIR
PREVENTION.

By

E. R. BURDON, M.A., F.L.S.,
Cambridge.

WITH FIGURES A AND B.

THE Pine-apple galls of the Spruce Firs, and the Blight, or Bug of the Larch, are diseases well known to every forester and gardener, and numerous attempts have been made from time to time to find some means for preventing the damage done in plantations and gardens by these diseases.

In this, as in every other disease, the spread of accurate information as to the life-history of the parasite responsible for the disease is most important, for unless this is thoroughly understood, any attempts to remedy the evil are likely to prove abortive.

The important fact to bear in mind about these two diseases, is that they are both caused by different generations of one and the same insect, viz., the genus *Chermes*, belonging to the family *Aphidae*.

Thanks to the patient labours of Blochmann, Dreyfus, Cholodkovsky and others during the past twenty years in Germany and Russia, many of the main points in the complicated life-history of this peculiar genus of *Aphidae* have been unravelled, and although we are still in the dark about some details in the life-histories of the separate species, sufficient information has been gathered as to the genus as a whole, to enable intelligent experiments to be made for preventing the spread of these pests.

The results of the work on *Chermes* done on the Continent are not as widely known in this country as they should be, and the majority of the accounts found in English works are inaccurate and misleading.

Most English writers have relied on the account of *Chermes* given by Buckton in his Monograph of British Aphides, but this is unfortunately full of mistakes and quite unreliable, whether regarded from the entomological or the botanical point of view.

His book was written before the discovery was made that the *Chermes* of the Larch were not separate species, but merely the descendants of a generation of Spruce *Chermes*, which had migrated to the Larch, so that Buckton regarded them as distinct species. But quite apart from this the different species are confused, the account given of the structure of the insect is unreliable, and the description of the habits of the gall-Foundress is so confusing that one is almost inclined to doubt whether the author knew which insect was the actual Foundress. On one page she is described as viviparous, on another as laying heaps of eggs. In one paragraph he expresses a doubt as to whether the Queen-mother dies outside the developing gall or accompanies her offspring into the chambers, yet later on he states that 20 to 50 larvae are to be found in each chamber with the Queen *Chermes* in the midst surrounded by her progeny.

His statement that he discovered wingless males in the gall, and proved their sex by dissection, has never been confirmed by any subsequent observer. The drawing given of this male *Chermes* leaves little doubt that Buckton was misled by a bad preparation, and mistook an ordinary gall larva for an adult male. The few remarks made about the way in which the gall is formed are as inaccurate as his description of the insect.

These statements have found their way into the majority of our English accounts, and it is time for us to drop Buckton as an authority on *Chermes*, and spread a more accurate knowledge of the facts brought to light by the Continental observers mentioned above.

Before going further, I propose therefore to give a brief *résumé* of the chief points in the life-history of the insect, and we will take as the starting point the hibernating generation on the Spruce.

Generation 1, Fundatrices.—In the autumn a *Chermes* larva takes up its position at the base of a bud on the Spruce, and driving its long proboscis into the stem just below the bud, or into the bud itself, it anchors itself securely to the plant and passes into a hibernating condition. The insects are almost invariably found on the underside of the bud, in which position they are well protected from the effects of heavy storms in winter. In the spring the insect awakens, and, without stirring from the spot to which she is attached, begins to suck, and at the same time to secrete tufts of white wool-like wax from glandular plates on the dorsal side of her body. She rapidly increases in size, undergoes three ecdyses, and then, having reached

maturity, lays numerous eggs which are attached to the stem by delicate hair-like stalks. This generation consists entirely of wingless parthenogenetic females. While this process has been going on, the bud, still enclosed in the winter bud-scales, has become much enlarged in consequence of the insect's action, and if the scales are removed the young gall is at once visible to the naked eye, not only on account of the abnormally swollen condition of the stem and bases of the young needles, but also on account of its bleached appearance, since the insect has destroyed the chlorophyll.

Generation 2, Alatae.—By the time that the first eggs laid by the gall Foundress are about to hatch the galled shoots are beginning to emerge from the winter bud-scales, these last being carried up on the apex of the elongating shoot in the form of a calyptra. The larvae creep on to the young shoot, where they find a soft succulent tissue already prepared for them. Owing to the arrangement of the needles on the shoot, *i.e.*, the phyllotaxis, and the way in which the swelling proceeds, the space in the axil of each needle becomes gradually converted into a chamber, into which the larvae make their way. As growth of the gall proceeds, the mouths of these chambers become closed by the growth of tumid lips, and the larvae thus concealed and protected complete their development inside the chambers. About June or July the galls begin to dry up, the chambers open, and the inhabitants creep out as Nymphs on to the neighbouring needles to undergo their final ecdysis, from which they emerge as winged adults. They again consist solely of parthenogenetic females, who at once fly off to lay their eggs on other trees.

The habits of this winged generation differ according to the species. In one or two species the insects merely fly to other Spruce Firs, and, seating themselves on the needles, there lay eggs from which the winter mothers of generation 1—the Fundatrices—develop, and in this case therefore the life-cycle is completed in one year, and reproduction seems to be entirely parthenogenetic.

In the majority of *Chermes* species, however, when the Spruces on which they have developed happen to be growing amongst other Coniferous trees, a migration takes place to an Intermediate Host. This migration may be either complete, that is to say, the whole generation migrates, or only partial, in which case the generation splits itself up into two parallel series, the Migrants and the Non-Migrants.

The latter behave like the non-emigrating species described above, *i.e.*, they lay eggs on the Spruce needles, from which Generation 1—the Fundatrices—hatches forth. The emigrants, on the other hand, fly off to another species of Conifer, the Larch, Pine, or Silver Fir, as the case may be, and lay their eggs on the needles of these trees.

The tree selected as intermediate host differs according to the species of *Chermes*, some species selecting the Pine, others the Silver Fir, and others again the Larch. I am uncertain whether the species which migrate to the Pine and Silver Fir are found in England. The Larch is the intermediate host which is most attacked in this country, and numbers of winged emigrants from the Spruce galls may be found laying their eggs on the needles about the middle of summer.

Generation 3, which I have called the *Colonici*, develops from the eggs laid by the *Migrantes-Alatae* on the Larch needles. The larvae suck for a time on the needles, and then, as autumn advances, make their way into crevices of the stem. Driving their proboscides into the bark, they anchor themselves in the same way as the winter mothers on the Spruce, and then pass into a hibernating condition. In the spring they awaken, and, without moving from the spots where they lie, commence sucking, undergo three ecdyses, and then lay heaps of eggs. This generation also consists of parthenogenetic wingless females, and it is remarkable that, although closely resembling the Foundresses on the Spruce, they do not cause the formation of a gall on the intermediate host, a fact for which I am unable to offer any explanation at present.

Generation 4, Exules and Sexuparae, arises from the eggs laid by the *Colonici* on the intermediate host. The larvae swarm up on to the tender needles and shoots which are just beginning to sprout. As the larvae continue to grow a differentiation becomes noticeable, for while some of them show no marked segmentation of the body, others have their bodies distinctly segmented into head, thorax and abdomen. After the third ecdysis the differentiation becomes more marked, and it is then seen that the generation is splitting into two parallel series. The one series, known as *Exsules*, consists of wingless parthenogenetic females, which remain on the Larch and lay eggs from which other parthenogenetic generations arise. They or their descendants are to be found on the Larch the whole summer through, readily visible at some distance, and looking like white flecks of wool attached to the needles.

The individuals of the other series undergo one more ecdysis than their wingless sisters, and emerge as winged insects. They also consist entirely of parthenogenetic females, and this series is known as the *Sexuparae*, since from their eggs arises a sexual generation. The *Sexuparae* re-migrate to the Spruce, and lay their eggs on the needles of the preceding year, where they may be found any time about the middle or end of May.

Generation 5, the Sexuales, arises from the eggs laid by the sexuparous series of *Generation 4*. I have not yet succeeded in following

this generation through every stage to maturity, and must rely entirely on Cholodkovsky's account. The adults are exceedingly minute wingless insects, and consist of males and females, the former being smaller and more active than the latter. After copulation the female betakes herself to a crevice of the bark, or conceals herself beneath scales, and there lays a single comparatively large egg. From this egg arises a hibernating Foundress of Generation 1, and the cycle begins once more.

The accompanying table will, I think, be of assistance in making clear the main facts in this complicated history, as the whole life-cycle is seen at a glance.

	Primary Host, Picea.	Intermediate Host, Larix (or Pinus, or Abies.)
1st year	<p>I. Fundatrices { <i>hibernate—cause galls—</i> <i>wingless—all ♀</i></p> <p>II. Alatae { <i>larvae inhabit gall—</i> <i>adults winged—all ♀</i></p> <p>Non migrantes Migrantes</p>	
2nd year	<p>I. Fundatrices (<i>as before</i>)</p> <p>II. Alatae (<i>as before</i>) Non migrantes Migrantes</p> <p>V. Sexuales { <i>wingless—</i> <i>cause no</i> <i>gall—♂ & ♀</i></p> <p>to <i>Larix</i> <i>as before</i></p>	<p>III. Colonici { <i>hibernate—cause</i> <i>no gall—wing-</i> <i>less—all ♀</i></p> <p>larvae live on the needles—cause no gall—all ♀</p> <p>IV. Sexuparae Exsules <i>adults winged</i> <i>adults wingless</i></p> <p>Exsules</p>
	<p>I. Fundatrices I. Fundatrices</p>	<p>?</p>

It will be seen that the Fundatrices may arise either parthenogenetically or from fertilised eggs, and that even if the insects were exterminated on one species of tree, a fresh supply would soon arise in consequence of the emigration from Spruce to Larch, and *vice versa*. This point should be borne in mind also when new plantations are laid out, and Spruce and Larch should not be mixed together, as this arrangement furnishes the insects with the most favourable conditions for development. On the contrary, the plantations should be separated when possible by a belt of broad-leaved trees, which would probably render migration impossible.

The object of migration to an intermediate host seems to be for the set purpose of introducing the male element by means of a sexual generation, though only a portion of the emigrants succeed in realizing this object. Possibly the Exsules give rise to a winged sexuparous generation in the following year, but I do not think that anyone has yet succeeded in following up their complete history, or finding out how long they can continue to reproduce parthenogenetically without the intervention of a sexual generation.

The same remark applies to the non-emigrating species on the Spruce, for so far as I am aware no sexual generation has yet been discovered amongst them, and parthenogenetic reproduction appears to be the rule.

The fact that these insects are found year after year on Spruces which are quite isolated, and have no other Conifers growing near them, looks as if these *Chermes* can continue to live and multiply without migration to an intermediate host. But there is also no doubt that when intermediate hosts *are* present, migration goes on on a large scale, and that the disease increases much more rapidly.

Having now, as I hope, placed the main points in the life-history clearly before you, we will consider the damage done by these insects to the host-plants. The injury to both primary and intermediate host is very considerable. In this country the Spruce and Larch are the chief sufferers, and the Pine and Silver Fir do not appear so subject to attack.

The damage to the Spruce if the galls are at all numerous is very serious. This tree, like many other Conifers with crowded leaves, only develops very few buds in the axils of the leaves, and in the majority of the axils buds are entirely absent. The number of buds produced on a single shoot each year rarely exceeds a dozen to fifteen, unless the tree shows exceptionally strong growth, while six to ten is the more usual number. All these buds develop in spring, and there are consequently no "dormant eyes" to replace failures. If any of these buds therefore become transformed into galls, the damage is

far more serious than it would be in the case of a tree with buds in every axil, for the Spruce has no reserve of buds to fall back upon. It is no unusual occurrence for one half of the crop of buds on a shoot to become galled.

The position of the Foundress in relation to the buds varies slightly in the different species of *Chermes*. *C. coccineus* and *C. strobilobius* are almost always found seated about halfway up the bud; *C. abietis* usually nestles down at the base of the bud, and Cholodkovsky¹ has found a species, *C. sibiricus*, which often seats itself on the bark a little distance below a bud. The effect of the insect on the bud varies inversely as the distance of its proboscis from the apex of the bud. The reason for this is that the apex of the bud is in a more embryonic and plastic condition, and less differentiated than the basal end, and responds more readily to the irritation of the insect.

In the cases of *C. coccineus* and *C. strobilobius* the bud becomes completely modified into a gall. The shoot rarely continues to grow beyond the gall, and as soon as the gall begins to dry up all further branching from that bud is brought to an end.

C. abietis, which is seated at the base of the bud, usually affects only one side of the young shoot; the other side of the shoot remains normal, and growth is continued beyond the gall. Such a shoot is of course much weakened; it produces fewer and less healthy buds, and sometimes withers before the summer is over. If it lasts through the winter, and escapes being again attacked by *Chermes*, it may eventually recover, but a second crop of galls in the following year would probably determine its fate and cause its death.

The effect of *C. sibiricus* is much less harmful, owing to the greater distance of the Foundress from the plastic embryonic tissue. The stem and the bases of the needles only become slightly swollen and curved, and the elongation of the shoot is not checked or retarded as in the cases mentioned previously.

It is therefore apparent that the nearer the Foundress is to the apex of the bud the more deadly is the effect.

Whether the shoot is completely or only partially galled depends also, of course, on the number of Foundresses that attack the same bud. Where only one or two are found on a bud the effect will depend upon the position of the insects on the bud, but if six to eight, or even more Foundresses all set to work at one bud the shoot will become completely transformed into a gall, whatever be the species of *Chermes*.

¹Cholodkovsky.—Beiträge zu einer Monographie der Coniferenläuse. Horae Soc. Entom. Ross. T. 30, pp. 1-102; T. 31, pp. 1-61.

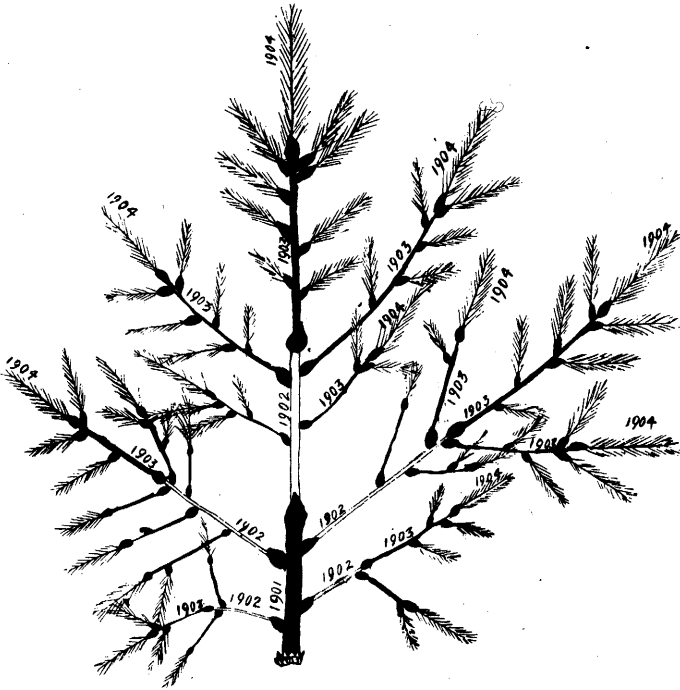

FIG. A.—Development during the years 1902 to 1904 of a healthy Spruce shoot which was laid down in 1901, and bore five buds.

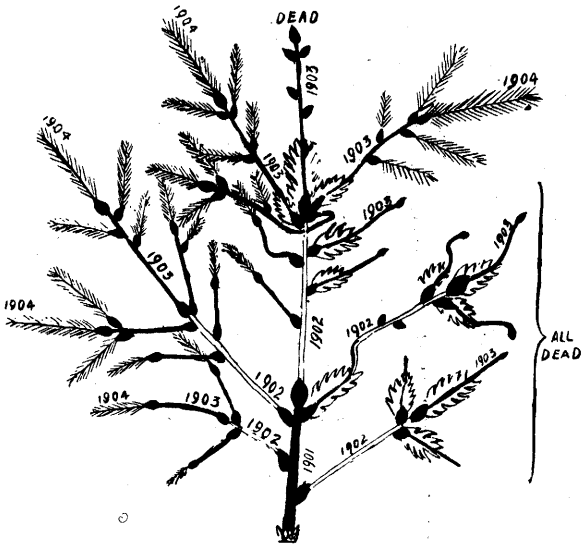

FIG. B.—Development during the same period of a Spruce shoot with five buds, which was taken from the same tree as A, but was attacked by *Chermes* in the first two years.

In the cases of shoots which are only partially galled curvature sometimes ensues, and the shoot becomes very brittle at the point where the curvature took place, and is easily broken by wind and weather.

If this debilitating process is long continued, the tree not only becomes most unsightly from the numerous dried galls borne on the branches, but the ultimate shape is much impaired, and gaps occur which destroy the tapering symmetry. The tree at the same time loses its health, and, if the evil spreads without let or hindrance, death will eventually result.

The accompanying diagrams, drawn from actual cases, show how great the damage may become in the short space of three years. Diagram A shows the development of the apex of a healthy branch in three years from a shoot which was laid down in 1901 and bore five buds. The shoot in diagram B started in the same year, on practically equal terms, with a crop of five buds. In 1902 one of these was galled. In 1903 every bud on the right side of the main axis, and three out of the four terminal buds were galled. The solitary sub-terminal bud which escaped attack was, however, so crowded by the three galls that the shoot was forced to curve round to the opposite side of the main axis, and was weakly in consequence. Of the shoots galled in 1903, only two managed to survive the winter and develop fresh shoots in 1904, and all the others, including the leader, died. The three lowest shoots on the right-hand side died without even being able to form their winter buds.

It has been stated that the damage done by *Chermes* on the Spruce is not of a serious nature, but I think the above facts are sufficient to show that the injury is by no means to be lightly regarded, and anyone who compares healthy trees with those which have been galled year after year, will at once realize how extensive and far-reaching is the injury caused by *Chermes*.

As regards the Larch, the damage done by the hibernating generation, the *Colonici*, is not apparent *at first*, since no gall is formed, and there is consequently no outward and visible sign to mark the presence of the insects. But the continual sucking of numbers of these Larch bugs must have a very weakening effect on the trees. It is only when the next generation, the *Exsules* and the *Sexuparae*, have reached maturity, and patches of white wool begin to appear scattered over the needles, that one realizes that there is anything seriously wrong. Then examination of each infected needle shows a very slight swelling at the spot where the insect is seated. The chlorophyll in the vicinity has been destroyed, and the needle has become bent into the shape of a knee, and a month later the distal portion of the needle

above the spot where the *Chermes* was seated is found withered and dead. The descendants of the Exsules make their way to other needles, and they begin to suffer in a similar manner. Now, however, the needles have completed their growth, the vascular bundles have been lignified, and the epidermis cutinised, with the result that no curvature of the needle takes place. But at whatever spot the *Chermes* is seated, and this applies equally to those generations which live on the Spruce needles, the chlorophyll is destroyed, and the needles become marked with yellow patches. The same action is noticeable in Spruce galls, which, in their youngest stages, are quite pale and devoid of chlorophyll. Later on, as they emerge to the light, the plant struggles to gain ascendancy over the insect, and the extent to which it succeeds might almost be measured by the colour of the gall, since its first efforts are to replace the chlorophyll destroyed by the insect.

With the disappearance of the chlorophyll the function of the leaves is destroyed, the work of assimilation is stopped, and the needle dies. By the end of June the descendants of the Exsules have increased at such a prodigious rate, that a badly infected tree looks as if covered with mould, and the needles and shoots are everywhere turning yellow and dying. The injury to the health of the tree is enormous. A few years ago some Larch plantations in Yorkshire were so badly infected, that after walking through them, one's clothes were covered with white flecks of the wool of these insects, which was being carried in all directions by the wind. It was doubted if the trees could possibly recover from the effects, and I have since heard from the owner that he had to cut down and burn the majority of the infected trees, involving a sacrifice of some 5,000 eight-year-old Larches.

In addition to the immediate damage inflicted by the *Chermes*, there is the train of evils which follows in the track of galls and blight. The trees become less able to withstand the attacks of other parasites; boring beetles and wood wasps find the sickly Spruce and Larch an easy prey, and, burrowing into their trunks, hasten on their death. Fungi, such as the Larch canker (*Peziza wilkommii*), and the Spruce shoot disease (*Septoria parasitica*) also make their appearance. *Peziza wilkommii* can only, as Hartig pointed out in his "Baumkrankheiten," germinate on a wound, and there is no doubt that this canker frequently gains entrance into the trees through the wounds made by *Chermes* and other insects. *Septoria parasitica* probably gains entrance into the Spruce in a similar manner, for I have often found hyphae which I believe to be those of this or some closely allied fungus, ramifying through the tissues of the old dried galls, and at certain times of the year its minute, black, bead-like fructifications are to be seen projecting from the surface of the gall. Whether the hyphae pene-

trate into the living tissue adjoining is a point I have not yet ascertained.

My attention was first directed to the need of finding some better method for preventing the disease than those usually adopted, by the foreman of a large nursery garden. He had been specially troubled by galls on the young Spruce Firs, and had attempted to diminish the evil by snipping off the galls in summer, a treatment generally recommended in most books and reports dealing with the subject. For work of this kind, when carried out on a large scale, ordinary labourers have to be employed, and, in summer, when there are so many other things needing attention in Horticulture or Forestry, it was impossible to give the workmen the necessary supervision. The result was that the cure was sometimes worse than the disease, and the trees were often more damaged than they would have been had the galls been left. But apart from this the results were unsatisfactory, since in another year or two the crop of galls seemed just as heavy as ever. This, of course, is only what we should expect after a consideration of the insect's life-history, since the supplies on the Spruce are kept up by the return of the sexuparous generation from the Larch.

There is another objection to the method of cutting off the galls, for, as mentioned above, in the case of *Chermes abietis* the shoots are frequently galled on one side only, and continue to grow normally above the gall. There is always the possibility that the shoot may eventually recover from the effect if it escapes being galled the following year. This does frequently happen, but removal of the gall of course prevents all chance of this occurring.

The only galls which, in my opinion, ought to be removed, are those which involve *the whole shoot* in their formation, as in these cases there is no possible chance of the shoot recovering and making further growth. As, however, the men employed to do the work would probably lack power of discrimination, the wisdom of recommending such treatment appears doubtful.

Various washes have been recommended at different times for spraying the trees, and some of these have been used with a certain measure of success. Miss Ormerod stated that drenchings with any of the Aphis washes in July, or when the *Chermes* were seen to be hatching (*i.e.*, in April) would be useful in clearing many from the trees. She also gave a list of washes which have been found efficacious in reducing the number of insects on the Larch. These washes were also applied in spring or summer.¹

¹ E. A. Ormerod.—Manual of Injurious Insects. 2nd Ed., pp. 220-6, 267-270.

Blandford recommended washing in April as likely to give good results.¹

MacDougall carried out some spraying experiments in the spring and summer of 1900 on a comparatively large scale in some infected plantations in Scotland.² He used three different washes:—

1. Pure paraffin, which generally killed the insects, but was rather a dangerous remedy to use in plantations on account of the risk of fire. It was, moreover, found liable to scorch the foliage.

2. A solution of soft soap was also effective in getting rid of the insects, but the foliage of the Spruce suffered badly, though, curiously enough, the more tender foliage of the Larch was unaffected.

3. An emulsion of paraffin and hard soap gave fairly satisfactory results, though here and there badly infected trees still had insects left on them.

There is no doubt that spraying infected trees in spring and summer considerably reduces the number of insects, but it is not absolutely effective, and there are several objections to the method.

In summer, and especially in spring, when the shoots and needles are young and tender, there is considerable danger of injuring the young foliage, which, as we have seen, was frequently scorched in MacDougall's experiments.

With Spruce Firs spraying in June or July would only destroy a proportion of the insects, for the fluid would not reach those which still remained in unopened galls.

Spraying in April, when the young *Chermes* are seen to be hatching, would destroy a good number of insects, but it would lead to disappointment in many cases, for the owner might find a fair crop of galls later on in spite of his efforts. He would conclude that the wash was ineffective, and not try it again the following year. In this he would be wrong; the wash did its work, but was applied too late to stop the development of the galls, for some experiments which I made in 1903 showed that if the winter-mother is allowed to suck until she reaches maturity, *but removed just before she begins to lay eggs*, the galls continue to develop after her death.

It occurred to me that the method of washing the trees in winter might give better results than spring or summer washing. There would be less risk of injuring the trees at this time, as the Larch loses its leaves in winter, while the Spruce, Pine, and Silver Fir, all have their buds well protected by the resinous bud-scales. The work could also be better carried out, as not only are the trees more easily handled in

¹ W. F. H. Blandford.—Conifer Conference Report, 1891, pp. 169-176.

² R. S. MacDougall.—Trans. Highland and Agric. Soc. Scotland, 1900, Vol. xii, pp. 298-303.

their winter condition than when in full summer growth, but it is the slack time of year, when men could be more easily obtained.

In order to test the effect, I carried out a few initial experiments on a small scale during the winter of 1903, intending, if they gave encouraging results, to follow them up with more extended experiments another winter. The results obtained were most satisfactory, but, unfortunately, I was prevented from continuing the work in the winters of 1904 and 1905, and am only taking it up once more this winter.

As my small experiments may be of use to others, and enable them to test the efficacy of winter washing on a larger scale than I have been able to attempt, I will briefly describe the method adopted and the results obtained, without waiting for the results of this winter's work.

The Spruce Firs were the only trees on which I experimented, and for these two washes were used:—

A.—2 oz. paraffin, $\frac{1}{2}$ oz. soft soap, and 1 gallon of water.

B.—1 $\frac{1}{2}$ oz. caustic soda, 1 $\frac{1}{2}$ oz. caustic potash, $\frac{1}{2}$ teacup treacle, and 1 gallon water.

The latter wash was not effective, and there is no need to waste time in describing the experiments. The paraffin emulsion, on the other hand, in spite of being a very weak prescription, gave most encouraging results. Before washing, a certain number of infected buds were selected, and the number of insects on each bud counted. The apex of the branch bearing the infected buds was then dipped bodily into the wash-pail, and gently shaken in the fluid to make certain of all parts being thoroughly wetted. The insects were again counted after washing to see that none had been knocked off by the shaking.

Out of a total number of 63 Foundresses on 44 buds, only one insect survived the treatment, and 43 of the 44 buds developed into strong healthy shoots which showed no sign of gall formation. The single Foundress that escaped never looked quite healthy, and only caused a small and insignificant gall. The foliage of the tree was not in any way injured by the treatment, and in the experiments which I am now carrying out, I am using much stronger prescriptions in order to test the effects on the trees.

As mentioned above, my experiments were entirely confined to the Spruce, but it is evident from the facts of the insect's life-history, that the washing will not be successful unless neighbouring Larches are also treated at the same time. Pines and Silver Firs showing signs of infection should also be similarly sprayed.

NEW HEMIPTEROUS FRUIT PESTS IN BRITAIN.

By

FRED. V. THEOBALD, M.A.

WITH PLATES I AND II.

DURING the past summer and autumn a number of communications from various parts of Britain have been received concerning the damage done and the annoyance caused by the so-called "Leaf-hoppers." Most orchard trees have been attacked, and to some extent bush fruit.

Fortunately, three of these insects were found in my own garden in enormous numbers, and thus their habits and life-history could be more easily followed.

The Leaf-hoppers in all cases reported and observed proved to belong to three species of the Homopterous family *Typhlocybidæ*, namely, *Typhlocyba quercus*, Fabricius, *Chlorita flavescens*, Fabricius, and *C. viridula*, Fallen.

As no reference can be found to any of these insects in the literature on Economic Entomology in this country, the following notes on their life-history, the damage caused by them, and the means of holding them in check, may be of some interest, particularly as the damage they have done has in some cases been very great.

In other parts of Europe, and in America, there are many instances of damage caused to crops and fruit by both of the genera of *Typhlocybidæ* that are mentioned here (3, 17, 21).

That there are no published records of such damage in this country we may well imagine, when we call to mind the very scanty literature on the subject of our fruit pests. However, several growers I have consulted have noticed the damage caused by these Leaf-Hoppers on fruit previous to this year. An allied insect, *Chlorita solani*, was described by Curtis (5) in his work on Farm Insects, and an account given of its habits, and the injury caused to potatoes.

The Rose Leaf-hopper (*Typhlocyba rosae*, Linn.) is also well known as an enemy of cultivated roses (13). The Hop Frog Fly (*Euacanthus interruptus*, Linn.) (24), and the Elm Leaf-hopper (*Typhlocyba ulmi*, Linn.) are other instances of allied insects which do damage in this country. Edwards (7) does not appear to have been acquainted

with the economic literature of this subject, for he states in his work on the Hemiptera-homoptera of the British Isles (p. 3) that "none of the Homoptera-cicadina can be said to be of any economic importance in Britain; certain species, as *Philaenus spumaria*, *Chlorita viridula*, *Eupteryx auratus*, etc., sometimes swarm in gardens, and elm and beech trees are generally tenanted by countless numbers of *Typhlocybidæ*, but it does not appear they do any real harm in any stage."

The *Typhlocybidæ* are small Leaf-hoppers, which form a very homogeneous group, and some, such as the *Typhlocyba quercus* under discussion, are very gaily coloured, others, as the two *Chloritæ*, are more uniform in appearance.

No less than twenty species of *Typhlocyba* are known to occur in Britain. One species is described from plums (*T. pruni*, Edw.), another from nuts (*T. avellanae*, Edw.). Neither of these have been so far observed by me on fruit trees in any numbers, and in many orchards and plantations visited none could be found at all.

It is strange that one of the species that has been doing so much harm to fruit trees should be an oak feeder. At least, it has been identified as such by Mr. Distant, and it certainly answers the description of *Typhlocyba quercus* given by Edwards, although his figure does not quite agree with¹ any specimen I have. The series in the Douglas and Scott collection in the British Museum all agree with those that have been sent me.

The damage done by these Leaf-hoppers is very marked, and has been referred to by various writers abroad.

In the case of Apple and Plum the insects, by means of their probing proboscides constantly being inserted in fresh tissue, and constantly sucking out the sap, produce on the leaves, first, minute pale spots, which gradually increase until the leaves become more or less entirely silvery green, or grey, or marbled. To such an extent have I seen this effect during the past year that anyone would have thought, at a distance, that the trees were suffering from Silver Leaf disease.

The *Chloritas* and the *Typhlocyba* had all the same effect on Apple and Plum leaves.

On Cobs and Filberts the effect was not nearly so marked in this respect, but when the young leaves were punctured the result was equally striking, though very diverse—they become pierced with irregular slit-like holes. This is caused by the young tissue being damaged and splitting on further growth. Mr. Collinge tells me he has noticed this effect in roses. The mottling and paleness of the foliage is the most marked feature of their attack, however.

This we frequently see in Elms in this country, which have been

noticeably attacked during the past year in and around Brighton by *Typhlocyba ulmi*, Linn.

Similar effects are produced on Vines (17) in America (by *Typhlocyba comes*), and on Vines in Europe (by *Chlorita flavescens* and *C. viticola*) (12, 13, 14). The result of this damage is that the leaves lose their vitality and cease to exercise their proper functions, fall prematurely, and in bad cases of attack the fruit withers and drops. The growth of the trees is also checked.

The life-history of the *Typhlocybae* and *Chloritae* is different, so they are best treated separately.

THE OAK AND FRUIT LEAF-HOPPER.

(*Typhlocyba quercus*, Fabr. = *Typhlocyba flammigera*, Amyot.)

Like all members of this family, the insect passes the winter in either the adult or nymphal stages. Hibernation takes place in any sheltered position. One may find them amongst fallen leaves at the foot of hedgerows, in box hedges, amongst moss and lichens on trees, and abundantly amongst conifers. In spring they appear again, and feed upon the young leaves. In June they were first noticed in numbers; possibly between their exit from winter quarters and June a generation had appeared. It was not until July that any marked damage was done to the leaves of apple, plum, and damson, then all stages of the insect could be found at once, and the life-cycle easily followed. How many generations occur in the year could not be decided, but apparently more than two. The adult may be told by its beautifully-marked anterior wings, with six bright orange and vermilion spots, on a milky white ground, and with a large dusky network at the apex. They are subject to variation in regard to the markings.

Their length varies from 3 to 3.9 mm. Both nymphs and adults feed mainly on the under side of the leaves, but by no means always.

They are not very active, and can easily be taken at rest on a dull day. When disturbed they take a leap from the leaf, and then use their wings, often flying a couple of feet away.

Egg laying seems a laborious task. By means of the saw-like structure the female cuts a slit into the under epidermis, and places one or more eggs just beneath it. A very minute and faint oblong spot marks where they have been laid.

The ova are very delicate, white, and oblong-oval in form, somewhat curved on one side, and blunt at each end. When nearly ready to hatch they may be seen with a strong lens under the epidermis, their position being plainly marked by the dark eye spots of the embryos. Length, 0.04 mm.

Eggs under observation were found to hatch in four days, but how long they had been laid was not known. Slingerland (17) shows that the American Grape Vine Leaf-hopper (*Typhlocyba comes*) remains two weeks in the egg stage, and it is quite likely this is about the period taken by *Typhlocyba quercus*.

The young emerge on the under side of the leaf, and grow rapidly. There are four moults in the nymph stage. At first the young are very pale, but gradually become yellowish as the wing-buds develop. Towards the end of nymphal life they are most ravenous. The whole period of growth lasts from five to six weeks, the complete life-cycle probably taking fifty days.

They kept on breeding until the first week in October, but in very small numbers after the middle of September.

Until they are mature these Leaf-hoppers are very sedentary, and even when adult do not jump as do other members of their tribe.

The distribution of *Typhlocyba quercus* in Britain is probably very wide. Edwards (7) gives the following localities:—Norwich and Cotswold districts, Ireland (Haliday), Renfrewshire (Young), Dallington Forest, Totteridge, Barnet (Butler), Glanvilles Wootton (Dale).

During the past year specimens have been received from or taken in various places in Kent, Surrey, Sussex, Devonshire, Somersetshire, Worcestershire, Herefordshire, Monmouthshire, Huntingdonshire, and North Wales.

Amyot (20) (Ann. Soc. Ent. France, II, se. V, pp. 230-495) describes this insect as *T. flammigera*.

THE YELLOW LEAF-HOPPERS.

(*Chlorita flavescens*,¹ Fabr. and *C. viridula*, Fall.).

Two species of *Chlorita* were identified out of the specimens caught and received last season by Mr. Distant, namely, *C. flavescens*, Fabricius, and *C. viridula*, Fallen. Of these two, the latter seemed by far the most abundant, but both usually occurred together. The differences lie mainly in the male genitalia, but, roughly, when fresh they may be separated by the pale area on the anterior wings, the so-called supra-brachial area being hyaline throughout in *flavescens*, hyaline at the apex only in *viridula*.

These insects swarmed in greater numbers than the *Typhlocyba* in most districts from which reports were received. It may be pointed out that they soon fade after death, and the different species are then difficult to identify. They should be mounted in balsam.

¹ *Typhlocyba rosae*, H. Sch. (D. Ins. p. 124 1). *Eupterix flavescens*, Marsh, Ent. Mo. Mag., iii, p. 220-6. *Typhlocyba flavescens*, Flor. (Rh. L, II, p. 394-9). *Cicadula flavescens*, Sahlb. Not. Feim., xi, p. 161-3. *Chlorita flavescens*, Fab. Gli. Insetti. No., p. 154. Vol. 4.

One correspondent wrote from Southfleet on August 6th that his pickers had refused to work owing to the swarms of leaf-hoppers, which got into their eyes, ears, nose, and were drawn in at every breath. They had appeared in this manner several years previously. The grower wrote later that he had watched for them, and cleaned the trees with soft soap and quassia. They all fell to the ground, and he thought they had been made an end of, but on the following day they had revived, and were all up the trees again.

The effect of these Yellow Leaf-hoppers on Apple and Plum is very similar to that of the *Typhlocyba*, but in nuts they produced a curious split and jagged appearance of the leaves.

In life-history they differ from the pretty *Typhlocyba*. Like the latter, however, they hibernate as adults and nymphs, and in very much the same positions; in fact, they were frequently found in company during the winter.

The earliest time they were noticed on nuts was May 2nd, but doubtless they are about before then. Eggs were laid in June, and another brood appeared in August. Some eggs were brought me as late as October 23rd, and I saw one or two still unhatched on November 17th. A single individual was seen active early in December, the weather having been particularly open. I believe these *Chloritae* also have three, not two, broods. The eggs are laid by the female on the under side of the leaves, not under the epidermis, as in the former genus. The egg is white, broadly spindle-shaped, with prominent ribs running from pole to pole. Length, .8 mm.

The ova hatched in August in eleven days, and the nymphs at once commenced to feed.

The nymphs moulted five times, and reached maturity in about five weeks, a few in thirty days. When first hatched they are very pale, almost white, but darken as they grow, becoming pale yellowish-green. At each moult the insect fixes itself firmly to the under side of the leaf by its claws and proboscis. The cast skins remaining attached to the leaves a long time. Unlike the nymphs of *Typhlocyba*, they are very active, and run rapidly, but do not jump like the adults.

The adult *C. viridula* is green, with pale marks on the scutellum, a pale spot at the apex of the suprabrachial and sub-costal areas, and a large sub-triangular spot on the apex of the brachial area. The male has the white silky hairs on the apex of the genital plates, sub-equal in length to the erect bristles on the remainder of the same. Length, 3 mm.

C. flavescens is more of a yellowish-green, the entire supra-brachial area pale, also the apex of the sub-costal, and a spot at the apex of the brachial area. The white hairs on the apex of the male

genital plates are twice as long as the erect bristles, and the insect is somewhat larger ($3\frac{1}{2}$ to 4 mm.).

It may here be pointed out that a third species occurs in Britain, which is not mentioned by Edwards, viz., *C. solani*, Curtis. Edwards (7) (p. 198) says that Lethierry (10) in his "Catalogue des Hemipteres du Department du Nord," speaks of *C. solani* as generally common throughout the year, but does not mention *C. viridula*, and this circumstance raises the suspicion that the latter common European species was the one he had in view.

If *C. flavescens* and *C. viridula* are distinct, so is *C. solani*, which has a pale area running transversely across the wing, as figured by Curtis (5) in his work on Farm Insects (p. 438, and plate O, fig. 28).

The distribution of *C. flavescens* in Britain is given by Edwards as Norwich and Cotswold districts; Dublin (Carpenter); Hastings (Butler); Glanvilles Wootton (Dale). One could add some hundreds of localities. Suffice to say that it has occurred in such numbers as to cause damage in several localities in Kent, Sussex, Herefordshire, Worcestershire, and Huntingdonshire.

The allied species is also recorded from the Norwich and Cotswold districts; Pitlochry (Norman); Ardara (Johnson); Ireland (Haliday); Glanvilles Wootton (Dale); Hurst Green, Hastings, Ewhurst, and Chingford (Butler). Specimens have been received in all cases from the same localities as *flavescens*.

They are both probably found throughout the whole country.

NATURAL ENEMIES.

Quite a number of *Chloritae* and *Typhlocybae* were found to be attacked by parasites.

A Neuropterid *Eupsocus*, *sp.* (?) occurred in considerable numbers, and was bred with "hoppers" taken in Kent, Worcestershire, and Sussex, and a few from Devonshire.

I have been unable to follow what part these *Psocidae* play, but I have found them always in company with these homoptera, and cannot help thinking that they may have some connection with them. Saunders (19) records a Strepsipteron, *Eleuchus tenuicornis* (of Kirby) as a parasite of the allied *Liburnia* (Ento. Mo. Mag, III, 4 se, p. 249 and 279, 1892), and figures this parasitic colopteron emerging from the host. None have been bred from any of these insects received in 1906.

The two most important natural enemies of the *Typhlocybidae* are the Proctotrupids, of the genus *Aphelopus*, and Pipunculid larvae. Quite a number of the *Chloritae* and *Typhlocyba* examined from all

parts of Britain last year showed the extraordinary parasitic Proctotrupids of the genus *Aphelopus*. The infected individual looks as if its abdomen were bifurcated, for the "gall" produced by the parasite equals or rivals in size the abdomen of the host.

These "galls," for they are nothing more nor less than animal galls, have been previously noticed by Giard (8) in France, and he speaks of them as "*Thylacia*," a term which we may well adopt.

These growths are formed by a gradual dilatation of the hypodermis, which at the same time secretes an abnormal cuticle, more strongly adorned with undulating striae than that which actually covers the body of the homopteron.

This sac is normally attached to the dorsum of the second somite by a thick chitinous V-shaped area, which can be clearly seen in prepared specimens to mark the point of suspension of the sac.

In this sac lies the *Aphelopus* larva, and here it passes the later stages of its development. It lies bent on itself until the anterior and posterior extremities nearly meet at the point of suspension of the sac.

The two arms of the larva are distinctly separated from one another by a longitudinal partition, which divides the sac into two portions; these two areas communicate at the ends of the sac.

A narrow fissure, the margins and the posterior part of which are tinged with a black pigment, starts from the point of the chitinous V, and extends longitudinally for a distance equal to rather more than the length of the Typhlocybid somite. Frequently I have found these sacs break away and fall to the earth; the homopteron flies on unconcerned, just as it seems to have been by this additional load. Giard states that the host may die. More often this sac remains attached to the host until the Proctotrupid larva escapes. This exit takes place by the fissure extending to the free extremity of the sac and the consequent dehiscence of the larva, which falls either to the ground or on to the twigs or bark of the tree. It then pupates in a coarse case very similar to that formed by the Braconidae. The *Aphelopus* larva is long, and has a transverse row of long stiff bristles on each segment. There is no anus, and only a very rudimentary alimentary canal, but it is said by Giard to have well-developed mandibles. The fat-bodies are very voluminous, and are filled with rectangular crystals with a rectangular base.

The effect of these hymenopterous parasites is very marked. Giard refers to them as causing parasitic castration (Castration Parasitaire), a somewhat erroneous term.

The effect is generally to reduce the size of the external genitals, frequently to such an extent that only vestiges remain, and at the same time to alter their form.

We have other similar instances of this (Stilopization of *Andrenae* (23), and the Hermit Crab and *Peltogaster*) (16), but in which the parasitised individual takes on the characters of the opposite sex.

The effect of the *Aphelopus* is different on male *Typhlocybidae* in different species, according to Giard. For instance, he found that in *T. douglasi*, Edw., the alterations very slight, whilst in *T. hippocastani*, Edw., they were very great.

In the males of the species I have seen the reduction was similar. The effect of the alterations in *T. hippocastani*, Edws., according to Giard, are such that it become like *T. rosae*, Linn.

In the females I find that the saw-like ovipositor becomes so reduced that it is useless for puncturing, and is frequently entirely absent.

The parasites did not seem to me to affect the general health of the hosts in any way, and I found that parasitised individuals lived just as long as those which are not, but Giard speaks of "abortion of function, and finally death of the insect."

At the same time, by destroying the genitals, they must act very powerfully as natural checks, owing to stopping egg-laying. Not only do they affect the primary and secondary genitals, but Giard noticed that "modifications are seen in singular organs not hitherto noticed, which exist in the male of *T. douglasi* and *T. hippocastani*, the function of which is quite enigmatic. These organs consist of two invaginations of the integument that divide the ventral surface of the first segment of the abdomen, and reach, like fingers of a glove, up to the extremity of the fourth segment, and sometimes a little beyond. They appear to be homologous with the phonic organs of male *Cicadae*. Amongst the male *douglasi* and *hippocastani* infested with *Atelenura* and *Aphelopus*, the ventral invaginations are greatly reduced, generally they do not reach the second segment of the abdomen, and often exist as two small gussets on the first." I have been unable to detect these organs in the species dealt with here.

The colour of the "Thylacia" varies. Some are yellow, others almost black, on both *Typhlocyba quercus* and *Chlorita flavescens*. Giard also noticed this, for he tells us that those he found in the gardens of the Luxembourg were yellow, those which he found so commonly at Wimereux and in the woods at Meudon upon *T. hippocastani*, *T. ulmi* and *T. opaca*, were black. I am not sure if in all cases this is due to different species of *Aphelopus*, as only one hatched from those under observation. Walker has described no less than fifteen *Aphelopus*, but the types in the British Museum are in such poor condition as to be almost valueless, and I at present cannot identify the species bred out. The "Thylacia" were noticed by Giard infesting

nymphs during the latter half of June, the insects hatching in July. These deposited their eggs in the second brood of "Leaf-hoppers," and the parasites live in the hibernating nymphs all the winter, but do not appear to grow. The parasite found by Giard was identified as *Aphelopus malaleucus*, Dalman.

The majority of "Thylacia" I found were in August, and the last were not shed until nearly the middle of the month. The species is evidently quite distinct from Dalman's *A. malaleucus*.

The other important group of parasites are the larvae of the dipterous family of *Pipunculidae*.

Several larvae were found in *Chloritae* sent from Kent belonging to a species of *Atelenura*. In France the species found by Giard working with the Proctotrupids appears to be *Atelenura spuria*, Meigen. The effect of these larvae is also to produce parasitic castration. I do not know if any changes take place in the female hoppers.¹ The *Atelenura* larva lives within the body of the Typhlocybidæ. It lives with its head pointing towards the head of the host. The parasitized abdomen swells to such an extent that it passes well beyond the wings, so that an invaded specimen can at once be told.

When mature the parasite issues from the middle segments, always dorsally, and falls to the ground and becomes a naked pupa on the surface.

Atelenura spuria is known usually as *Chalarus spurius*; (*Chalarus*, Walker, 1834, *Atelenura*, Macquart, 1835).

It is also found in America (New Jersey, and New Hampshire), (*Vide* Cat. N. Ameri. Dip., p. 342. J. W. Aldrich, 1905) (1).

Boheenaus also has found *Pipuncula fuscipes*, Fall., infesting *Cicadula virescens*, Fall. It is thus probable that *Pipunculidae* generally are parasitic on the homopterous *Cicadulidae*, and the Proctotrupians of the family *Dryinidae* and *Aphelobidae* are parasitic on *Jassidae* and *Typhlocybidæ* respectively.²

PREVENTION AND TREATMENT.

The nymphs of these Leaf-hoppers may be destroyed by washing with dilute paraffin emulsion, particularly when young.

Of the various strengths experimented with the following formula was the lowest found successful, and thus adopted:—

Paraffin (Tea Rose)	-	-	-	3 gallons.
Soft Soap (Chiswick)	-	-	-	10 lbs.
Water	-	-	-	100 gallons.

¹ Giard distinctly states so.

² Perris found *Dryinus pedestris*, Dalm, on *Athysanus maritimus*, Perris.

Mik found *Gonatopus pilosus*, Thoms., on *Deltocephalus xanthoneurus*, Fabricius.

This, if sprayed with a fine nozzle, was found to have no effect, nor were any of the other formulæ used until such a quantity of paraffin was employed as to do more harm than the hoppers!

The success in destroying the nymphs lies in giving the trees a good soaking. In fact, in all spraying for insects, the "mystifying" idea should be abolished, unless we persist in using Paris green and pure oils. In America (21) they have found that 1 lb. of whale oil soap to 10 gallons of water enough to kill the nymphs of the allied *Typhlocyba comes*. With soft soap this was not sufficient.

In all cases two washings were found necessary, partly on account of fresh hatchings. The second should be done two weeks after the first.

The adult hoppers can also be destroyed by spraying; they must first be knocked off the trees by a plain, not strong soft soap wash, when they will be found, as Mr. Chambers describes, lying as if dead on the ground; they can then be further sprayed on the ground with strong paraffin emulsion (25 per cent. paraffin). This method, which is employed in America, was found to be completely successful here.

No wash will kill the adult hoppers on the leaves that is not so strong that the foliage is destroyed by it. The adults may also be caught in large numbers on tarred cloths, stretched on a light wooden frame, and held on each side of the trees, which are then jarred so as to make the insects move from shelter, and thus get caught in the tar. This is a laborious undertaking, and is no more beneficial than the washing treatment mentioned.

DAMAGE BY TYPHLOCYBIDÆ IN EUROPE, AFRICA, AND AMERICA.

There are many references to these insects doing damage in Europe. Reh (17 and 18) refers to *C. flavescens* and a *Typhlocyba*, sp., in Germany (Phytopath. Beobachtungun, p. 184, 1902; and Sond für Pflanzenschutz, p. 134, 190, vi. 1903). Vineyards in Algeria and Tunis are ravaged by *C. flavescens*. In the Isles of Elba and Pianosa *T. viticola*, Targ., is very harmful (Vide Insecta de la Vignes, p. 16, 1890, Mayets; Gli Insetti Nocivi, Vol. 4, p. 161 (1901), and Nuove Relazioni R. Stazione di Entomologia Agraria di Firenze, Se Pri. No. 4, p. 451 (1902), Leonardi).

In America, an allied insect—the Apple Leaf-hopper (*Empoasca* (*Chlorita*) *malæ*, Le B.), attacks apples and currants in a similar way, and does considerable damage to young stock and in nurseries, and causes very similar effects on the leaves. (Rept. Connecticut Agri. Exp. St., 4th Report St. Entomo., III, p. 216, 1905. W. E. Britton).

Chlorita flavescens, Fabr., is also referred to in America (U.S.

Nat. Mus. Proc., 20, 145). The Grape Leaf-hopper (*Typhlocyba comes*) is allied to the *Typhlocyba* mentioned here, and is very harmful to grape vines (Bull. 215, 1904., Cornell. Exp. St. M. V. Slingerland). I have received two *Chloritae*, one undoubtedly *C. flavescens*, from Lower Egypt, where they do some harm.

REFERENCES.

1. Aldrich, J. M.—Cat. N. American Diptera. 1905.
2. Amyot.—Ann. Soc. Ent. France, II. Se. V. p. 230-495.
3. Britton, W. E.—Report Connecticut Agri. Experiment Station. 4th Rept. State Entomologist. III. p. 216, 1905.
4. Collinge, W. E.—Reports on Injurious Insects observed in the Midland Counties during 1904, p. 13, 1905; ibidem during 1905, p. 13, 1906.
5. Curtis, J.—Farm Insects.
6. Douglas and Scott.—Cat. Brit. Hemiptera. Heteroptera and Homoptera (Cicadina and Phytophires), 8vo. London. (Ent. Soc.) 1876.
7. Edwards, J.—The Hemiptera-homoptera (Cicadina and Psyllina) of the British Isles. 1896, pp. 271 + 30 plates. Cr. 8vo. London.
8. Giard, M. A.—Comptes rendus des séances de l'Académie des Sciences. Vol. cix. July 8, and Nov. 4. No. 19, pp. 708-710, 1889.
9. Gillette.—U.S. Nat. Mus. Proc. 20, 745.
10. Lethierry, M.—Catalogue des Hémiptères du Département du Nord. Hemip-Heteroptera. Misc. IV. p. 361, 8vo. Lille, 1859; 2nd ed. p. 413, 1874.
11. Leonardi.—Gli Insetti Nocivi. Vol. 4, p. 161. 1901.
12. Leonardi.—Nuove Relazioni R. Stazione di Entomologia Agraria di Firenze. Se. Pri. No. 4, p. 451. 1902.
13. Lucet, E.—Les Insectes Nuisibles aux Rosiers Sauvages et Cultivés en France, pp. 296-298, 1898.
14. Mayets.—Insectes de la Vignes, p. 116, 1890.
15. Melichar, L.—Cicadinen von Mittel-Europa. 8vo. Berlin, 1896.
16. Potts, F. A.—Quarterly Journal Microscopical Science. Vol. 50, Pt. 4, pp. 599-621, 1906.
17. Reh, Dr.—Phytopathologie Beobachtungun, p. 184, 1902.
18. Reh, Dr.—Sond fur Pflanzenschutz, p. 134, and 190. VI. 1903.
19. Saunders, E.—Entomo. Monthly Magazine, III. N. Se. p. 249 and 297, 1892.
20. Sahlberg, J.—Ofversight af Finlands och den Skandinaviska halföns Cicadariae.
21. Slingerland, M. V.—Bull. 215. Cornell Experiment Station, 1904.

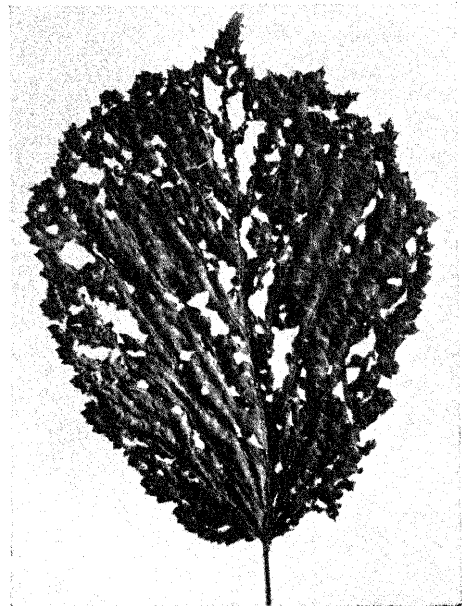
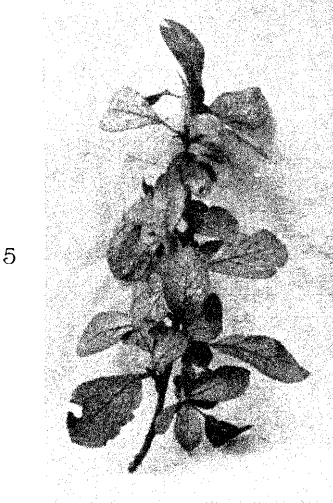
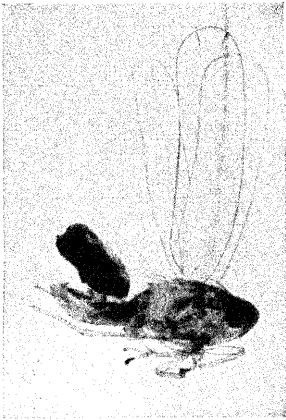
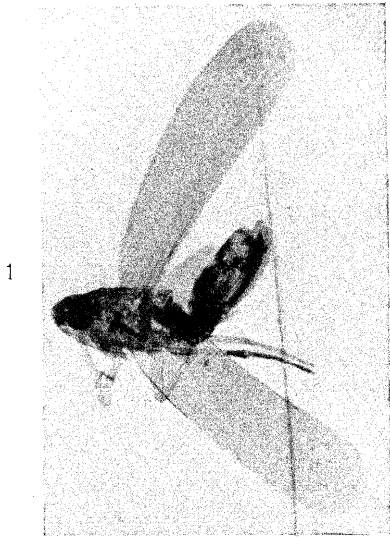

NEW HEMIPTEROUS FRUIT PESTS.



1.



2.



3.



4.



5.



6.



7.

Huth sc et imp

NEW HEMIPTEROUS FRUIT PESTS.

22. **Theobald, F. V.**—Report on Economic Zoology for year ending April 1, 1906, p. 76-78, 1906.
23. **Theobald, F. V.**—Entomo. Monthly Magazine, vol. iii, 2nd Se. pp. 40-42, 1892.
24. **Whitehead, C.**—Reports on Insects Injurious to Hop Plants, etc., pp. 18-21, 1885.

EXPLANATION OF PLATES I & II.

Illustrating Mr. Fred. V. Theobald's paper on "New Hemipterous Fruit Pests in Britain."

PLATE I.

- Fig. 1.—*Chlorita flavescens*, Fabr.
- Fig. 2.—*Typhlocyba quercus*, Fabr.
- Fig. 3.—*Chlorita flavescens*, Fabr., with Proctotrupid case.
- Fig. 4.—*Chloritae* on apple leaf.
- Fig. 5.—Plum foliage showing paleness, giving the effect of "Silver-Leaf," due to *Typhlocybidae* ($\frac{1}{3}$ rd nat. size).
- Fig. 6.—Nut leaf punctured by Leaf-hoppers when young.

PLATE II.

- Fig. 1.—Typical wing of *Typhlocyba quercus*, Fabr.
- Fig. 2.—Variety of above.
- Fig. 3.—Ovum of *Typhlocyba quercus*.
- Fig. 4.—Ovum of *Chlorita*, sp.
- Fig. 5.—Wing of *Chlorita flavescens*, Fabr.
- Fig. 6.—Wing of *Chlorita viridula*, Fall.
- Fig. 7.—Wing of *Chlorita solani*, Curtis.
-

HINTS ON THE COLLECTING OF TIMBER SPECIMENS.

By

HERBERT STONE, F.L.S., F.R.C.I.,

Four Oaks, Sutton Coldfield.

WITH PLATES III AND IV.

DURING the last few years it has been my lot to handle some ten collections of specimens of wood, from various Colonies, made chiefly with a view to ascertain their properties, and prospects of finding a place in the market. I have also inspected other collections made for public exhibition.

In every case I have been much pained to find that the object has been, in some measure, defeated by the defective condition, or unsuitable form of the material. For this reason I am of the opinion that a few suggestions may be of value to future collectors, as the task they undertake is by no means a light one, and is worthy of a better return.

The object in making such collections may be one or more of the following:—

- (A). A report upon the value of more or less unfamiliar woods, as material for works of construction, furniture-wood, and fancy and general woodware.
- (B). The precise identification of the species, accompanied by a description, to facilitate business, and to lead to their detection in fresh localities, where they may exist unrecognised under different local names.
- (C). The provision of material for scientific inquiry—Museum specimens and the like.

The preliminary steps necessary to attain any of these objects is much the same, but before felling trees careful consideration must be given to the precise end in view. If the object falls under Class A, then it is imperative that the selection shall be such as will commend itself to the timber-dealer and user. It is vain to send unsound, rotten, cracked, wormeaten, unripe or discoloured specimens. They will be accepted here as average samples, and however good a species may be,

it can stand little chance of a market if the impression created by the show pieces is bad.

The specimens should be taken from a straight, clean, well-grown tree, free from holes, wounds, and blemishes on the bark. No tree upon the stem or roots of which a fungus or parasite is growing must be used, nor one with dead branches of large size, especially those in the top. It is also well to avoid all such as are overgrown with strangling creepers, or epiphytes, whose roots or branches distort the form of their host. Scars on the bark, bordered by Callus-cushions, often indicate deep cracks and holes healed over, where hidden decay may be going on ; in fact, Callus is a bad sign in every case, and the collector should learn to recognise it. The bark should be searched for holes, indicating worm-galleries, which may riddle the tree-trunk. Decay and worm-holes frequently accompany each other. Loose bark that is dirty and dusty underneath, harbouring insects, or that can be detached too easily, is also to be distrusted, as is also any copious effusion of gum or resin.

The preliminary examination of the tree, as it stands, may save the felling of a useless tree, hence it is worth all the trouble it entails. A shapely tree generally makes good timber, but a gnarled one, "whose boughs are mossed with age, and high top bald with dry antiquity," is mostly cord-wood.

Providing that error is unlikely to arise in the naming, it is wise to enlist the good offices of the local timber-exporter. He will instinctively select sound timber, and will furnish such specimens as commend themselves to his judgment as a commercial man. Moreover, he may have logs ready seasoned in his yard, and thus shaky or cracked specimens, the greatest failing in Forester's collections, will be avoided.

Failing this resource, the tree should be felled and cross-cut into short lengths about 8 feet long. The best of these should be selected, the ends painted or smeared with cow-dung, after being duly numbered. For most purposes a portion of this log will suffice, and where carriage is difficult it is as well to split the log down the centre by means of wedges, and—unless a wide plank be needed—again into quarters. The halves or quarters should then be stored in as cool a place as possible, away from the direct rays of the sun. A thatch of sufficient thickness over the wood pile makes an excellent form of shed. The wood must rest upon cross-pieces, to keep it from contact with the soil, and the logs must not touch each other. The air should be allowed to circulate freely around them, but there should be no keen draught. They should remain in the store for some months, being examined at frequent intervals to protect them from white ants and other vermin.

Unseasoned wood is quite useless. By the time it arrives in Europe it is either cracked or in the process of decay, or both. No place is so bad for unseasoned wood as the hot, damp, ill-ventilated hold of a ship. Out of a collection of nearly one hundred specimens of the greatest interest, recently received, all but ten were in more or less evil case; some rotten, some cracked, some riddled with worm-galleries, and some all three. A few actually tumbled to pieces during the unpacking of the case.

The timber-buyer esteems wood of good dimensions, and is not impressed by narrow planks, having the sapwood (the outer lighter-coloured wood) running down each side. I remember a long series of such "sappy" planks at the Canadian Exhibition, at Wolverhampton, in 1902. They were Black Walnut, polished, and they looked very decorative as they stood in a row against the wall, but they were mere rubbish in a timber-buyer's eyes. Another instance of wasted effort was included in the same exhibit, namely a huge block of Oregon Pine (Douglas Fir), which was, so far as my memory serves me, about 4 feet square by 6 feet high. This impressive and noble piece of wood, though it attracted attention from every visitor, was quite valueless as a recommendation for the species, being cracked far inwards in many places. A third unfortunate example was a fine section of a Western Plane Tree, some 30 to 36 inches in diameter, obviously rotten in the centre. All these woods are in daily use in Canada, and for that matter in England, so that perfect specimens might have been selected from many wood-yards, and exhibited to the admiration of all.

Large diameters or width of plank are not needed in a collection of specimens for report. It is sufficient to mention the size in which species are readily obtainable. For exhibition, the wider the plank the better, and a wide plank is just as effective as a big log, for the buyer likes to see how the wood cuts up, and how it stands in plank form. A species prone to twist and warp will betray itself thus, whereas in the log it will not. A plank should be taken so as to show the pith on one face. It will then display the medullary rays or silver grain to fullest advantage, and will also show whether the pith will spoil the centre plank. In quartered wood the pith will generally be obliterated, but buyers want to know what to expect, for a large pith is a defect in a furniture-wood. Certain woods, such as the Gums or Eucalypti of Australia, when old, always have defective centres, and it is then customary to cut the planks in such a way (tangentially), so as to utilize the young outer wood only. I once had a collection of Australian woods in the form of fitches riven from the outside of the trees. These were useless in a great measure, as they consisted of bark, much sapwood, and very

little heartwood indeed ; the latter being, of course, the interesting part.

If tests of any kind are wanted, the form of the specimens should be appropriate. Here again short, quartered logs or thick planks are the best forms. The experimenter can cut from these such test pieces as his process may demand. For transverse breaking, and models of elasticity, test pieces 24in. by 1½in. by 1½in. are convenient. Laslett used pieces 6ft. by 2in. by 2in., and others use any size, down to as small as 6in. by ½in., but as the grain of wood is a wayward and wandering thing, and as one cannot see very far into the wood, it is certain that the larger the test piece, the less is the error on the score of hidden defects. On account of expense and the difficulty of transport, it is often impossible to furnish such samples as are here suggested, hence smaller pieces must suffice. These are not to be despised, but as they may twist in transit, plenty of margin should be allowed for squaring up.

It will be clear from these remarks that the forms which collectors have favoured hitherto, *i.e.*, a disc, or transverse section of a tree, a few inches deep, are quite useless for transverse-breaking tests, and for that matter, they fail to afford any proper idea either of their behaviour with tools, or of their appearance in the plank. On the other hand, they are quite appropriate to the purpose of identifying and describing the species, inasmuch as the transverse (cross) section is the important one as regards the structure ; and the presence of the Sapwood and Bark are valuable aids. In this respect, the amount of Heartwood which is present, if quite typical, is not material, so that, failing a log, a large branch will often meet all demands.

The chief aids to identification are the native and trade names, in whatever language, and evidence such as can be afforded by the fruits, leaves and flowers. Even a dead leaf, or a bunch of flowers, dried like herbs by the fireside or in the sun, are most valuable. Much better, of course, are properly preserved botanical specimens, dried between absorbent paper, but best of all are the systematic names furnished by a competent botanist who has seen the trees where they stand.

I have already touched upon the question of Exhibition and Museum specimens, and will now merely remark that "freak" exhibits are of doubtful value, and often cost a great deal of money. Any log bigger than those demanded by commerce, I class under this name. A mahogany log, 4ft. by 4ft., would be a fine item in a catalogue, because mahogany is wanted in wide pieces, but a wood used for construction, and customarily cut up before shipment, is best displayed in the form in which it is most generally used.

Excessive "polish" should be avoided, hence specimens should never be polished all over, unless an unpolished duplicate can be shown

beside each one. The exhibit is for the purpose of showing what the wood is, and not what the polisher can make of it. Polish is so susceptible of "faking" that the trader distrusts it. It is like a new label on a Chicago meat tin. It is no guide as to what is inside. It is quite possible to make an exhibit look too well; moreover, spirit polishes, such as are commonly used, change the colour of the wood materially. Woods of quite different colours assume a family likeness when polished, and in addition the open grain is filled up with powdered pumice, so that the specimen fails to show how much open grain there may be to fill up.

When small hand specimens are employed, care should be taken that they show all the possibilities of the grain and figure. If they are in the form of short planks, there should be one from the "quarter" (radial section), and one "plankwise" (tangential section), but there is no form for exhibition equal to a turned cylinder with a dome-shaped top. Its upper half may be polished. This form shows every variation of the grain from the radial or quarter, passing through all changes of figure to the "plankwise" section, and back again. Every possible figure obtainable from the wood is displayed upon the surface of the cylinder *twice over*, so that the front half of a specimen in a case or upon a shelf, shows all that is needed. Cylinders are cheap to make, and far cheaper than planks to polish, being finished in the lathe; and further, instead of having to select special figured pieces for show, any sawn piece (always excepting curly wood and the like) will produce the same effect when turned in cylindrical form.

All finishing, or anything beyond hewing or rough sawing, should be done in England. Such work is cheap enough at places where great exhibitions are held, and the disappointment of hearing that carefully prepared specimens have arrived cracked and disfigured by damp will be avoided.

Careful numbering of the specimens is essential. This is best done by means of iron number-punches, upon the transverse or cross section (end of the log). Chalk, labels of tin, and even paint, cannot be recommended. A set of punches with half-inch letters, in a leather case to go in the pocket, weighs very little, and takes up but small space. The back of an axe or a stone will serve for a hammer. When all else fails, a number can be punched by means of a nail, tracing out the line by a series of dots or Roman numerals; or it may be scribed deeply on the side of the log with a knife after removing a piece of the bark. The essential point is, that the mark shall be in a form that cannot be obliterated by weather and hard usage.

Packing and forwarding. Rough planks and logs (when the bark is of no consequence) may be painted with the shipping mark, and

Fig. 1.

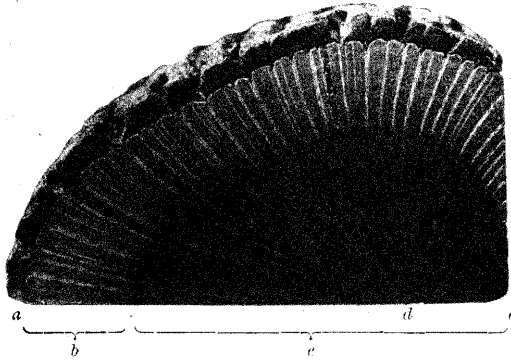
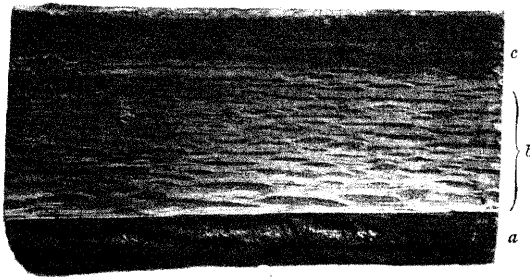

Fig. 2.



Fig. 3.



SECTIONS, ETC., OF WOOD OF STENOCARPUS.

SUMMARY OF CHOLODKOVSKY'S DESCRIPTION OF

Chermes orientalis, Dreyfus.¹ P.H. *Picea orientalis* (rarely
P. excelsa).
I.H. *Pinus sylvestris* and
P. strobus.

I. **Fundatrices:** P.H., seated on the stem some distance below the bud. Gall consequently longer, shoot being less stunted than in most other species. It differs from *Ch. sibiricus*-galls in the needles being equally affected on every side of the shoot, so that a complete, not merely a partial gall, is formed in which there are distinct chambers for the larvae. **Insects** almost identical with *Ch. sibiricus*-**Fundatrices**, but the two median rows of plates are placed so close together as to be almost fused.

II. **Alatae:**—Adults (migrantes) migrate to I.H.² The winged insects closely resemble the corresponding generation of *Ch. sibiricus*.

III. **Colonici:**—I.H. Very similar to corresponding generation of *Ch. sibiricus*.³

IV. Not described.³

V. **Sexuales:**—Red males and females found by Dreyfus on P.H. were believed to belong to this species.

¹No full description of this species was published by Dreyfus when he found and named it, and the few details given by Cholodkovsky are chiefly drawn from private letters of Dreyfus. Cholodkovsky has only met with two isolated examples of the gall on *Picea excelsa* in Russia, though he has often obtained them in material sent from the Caucasus.

²Dreyfus discovered this fact but never published it. Paul Marchal has, however, confirmed it as correct, stating that in the neighbourhood of Paris a regular migration takes place to the two trees mentioned above.

³The only examples which Cholodkovsky appears to have seen were bred from the **Alatae** which emerged from the two galls mentioned in note (1). He suggests that the species described on page 133, *Ch. pini*, may prove to be generations III., IV. and V. of *Ch. orientalis*.

SUMMARY OF CHOLODKOVSKY'S DESCRIPTION OF

Chermes piceae, Ratz.¹

P.H. Not known.

I.H. *Abies pectinata*.I. **Fundatrices**:—Not known.II. **Alatae**:—Not known.

III. **Colonici**:—The only generation of this species that is known probably corresponds with the **Colonici** generation of other species. It occurs on the bark, and is wingless when adult. **Insects** very similar to *Ch. funitectus*-**Colonici** without any fusion of the glandular plates on the abdomen, but the faceted areas of the median and marginal plates are absent, thus distinguishing it from both *Ch. coccineus* and *Ch. funitectus*. **Wool** present.

Ch. piceae var. **bouvieri** is a name given by Cholodkovsky to a variety found on the stems of *Abies nobilis* var. *glauca* and sent to him from the neighbourhood of Paris. The shoots bore club-shaped swellings on their distal ends and were covered with swollen and crowded buds, an effect which Cholodkovsky attributed to the influence of the insect.³

IV. **Exsules** and **Sexuparae**:—Not known.²V. **Sexuales**:—Not known.

¹ Ratzburg merely named the insect without giving any information about it except that it lived on the bark of Silver Firs and covered itself with white wool.

² Nüsslin's *Ch. piceae* being identified as *Ch. funitectus*.

³ The drawing of the swellings on the stem given by Cholodkovsky raises a doubt in my mind whether these are rightly ascribed to the *Chermes*. They look more like the effect of the fungus *Aecidium elatinum*, E.R.B.

SUMMARY OF CHOLODKOVSKY'S DESCRIPTION OF

Chermes pini, Koch. P.H. Not known with certainty (Spruce?)
Ditto var. pineoides. I.H. *Pinus sylvestris*,
P. strobus, etc.

I. **Fundatrices**:—Not known.¹

II. **Alatae**:—Not known.¹

III. **Colonici**:—I.H., chiefly on the young shoots. **Insects** dark red; **Wool** copious; **Glandular Plates** similar to those of *Ch. sibiricus*-Colonici. **Eggs** dark yellow.

IV. **Exsules, Exsules alati, and Sexuparae**:—The adult Sexuparae migrate to the Spruce,² the other members of the generation remain on the I.H.

Exsules.	Exsules alati. ³	Sexuparae.
Insects dark red covered with wool. Glandular Plates similar to those of <i>Ch. sibiricus</i> -exsules.	Of larger size, but otherwise identical with the Sexuparae . Eggs dark yellow, laid on the Pine. From these eggs hatch Colonici .	Adults very small, dark red; Wings whitish. Very similar to <i>Ch. sibiricus</i> - Sexuparae , but the conical joints (Nos. 3 and 4) of antennae are shorter and thicker. Eggs reddish.
Colonici (see Generation III.).		V. Sexuales :—Dark red.

Chermes pini var. pineoides:—Under this name is mentioned a variety which occurs on the bark of the Spruce, especially on weakly trees growing in shaded places. It closely resembles *Ch. pini*, but is somewhat smaller and is always wingless.

¹ Cholodkovsky suggests that these two generations are supplied by the species, *Ch. orientalis*.

² Cholodkovsky states that the **Sexuparae** are not produced every year as in other species, but that there are special swarming-years ("Flugjahre") in which they appear very numerous, whilst in other years they are almost entirely lacking. Although they lay their eggs on the Spruce, the **Sexuales** which hatch from them rarely live to reach maturity, and even if they do, their fertilised eggs shrivel up and come to nothing. Cholodkovsky's breeding experiments gave the same results, and he therefore regards the occasional migration as a remnant of a former habit which has almost disappeared.

³ The **Exsules alati** are practically **Sexuparae** which have given up the migratory habit, and with it, the production of a sexual generation.

SUMMARY OF CHOLODKOVSKY'S DESCRIPTION OF

Chermes viridanus, Chol. Host. Larch.

This species differs from all others in consisting of only one generation which lives entirely on the Larch. The larvae resemble the **Colonici** of other species in general appearance and habits, but after hibernating they undergo *four* moults instead of three, and become *winged* instead of wingless adults. These closely resemble the **Sexuparae** of other species. From their eggs however arises, not a sexual generation, but another generation similar to themselves. The larvae hatch from eggs laid on the Larch needles about the end of July, and Cholodkovsky says that they hibernate, without however describing either the insects in their winter state or the exact place of hibernation.¹ In the following May he says they are to be found on the young green shoots or cones, and in June to July they become winged adults which lay their eggs on the needles.

Larvae elongated-oval in shape, yellowish green. **Glandular Plates** represented by 6 longitudinal rows of indistinctly marked groups of 4 to 5 facets each; replaced later by the 6 typical rows of flat faceted warts. **Wool**; in May very little present, but the amount increases considerably after each moult. **Proboscis** long, the loop not quite reaching the end of the abdomen. **Nymphs** (after 3rd moult) dirty green with dark grey wing sheaths. **Winged adults** yellowish green, very similar to *Ch. viridis-Alatae*, with same structure of antennae and a thick yellowish green post costa. **Posterior wing** however with the fold and secondary nervure oblique instead of transverse to the longitudinal nervure. **Wax glands** strongly developed round margin of abdomen from which long threads of wool are excreted. **Eggs** few (about 14) greenish, thickly covered with wool.

¹For a more detailed description of the species and its life-history Cholodkovsky refers to a previous article which I have not seen. The paper is entitled "Ueber den biologischen Zyklus des *Chermes viridanus*." Revue Russe d'Entomologie, Bd. II, 1902.

Critical Observations and References to the Species occurring in England.

THE above list comprises all the different species which, according to Cholodkovsky, have as yet been met with in Europe. If we exclude *Ch. viridanus* as somewhat aberrant from the normal type, the remainder of the species can be separated into four distinct groups, according to the morphological characters of the hibernating larval FUNDATRICES.

1. *Ch. viridis* and its double, *Ch. abietis*, which possess glandular plates with 4-5 pores and short frizzly "wool."
2. *Ch. strobilobius* and its double, *Ch. lapponicus*, which possess glandular plates with only one pore and long straight "wool" hairs.
3. *Ch. coccineus* and *Ch. funitectus*, whose glandular plates are divided into irregular faceted areas, and the "wool" forms a dorsal crest and a marginal halo. The little that is known of *Ch. piceae* seems to connect it also to this group.
4. *Ch. sibiricus* and *Ch. orientalis*; glandular plates divided into irregular polygons, and "wool" forming a thick felted ball. *Ch. pini* probably belongs to this group.

Of these four main groups, three at all events are represented in this country, and it will probably interest entomologists to examine and compare with Cholodkovsky's descriptions my drawings of those species with which I have so far met. I should mention that my own work in connection with these insects has been chiefly directed to the botanical and economical sides of the subject, and I have made no attempt to study the finer sub-divisions of each main group. But I have no doubt that a more extended search would disclose the existence of most, if not all, the different breeds described by Cholodkovsky. I ought also to mention that I have never actually bred any one species continuously through its entire cycle of generations. I satisfied myself as regards *Ch. abietis* (or *viridis*?) and *Ch. strobilobius* (or *lapponicus*?) that the ALATAE on emerging from the galls do in some cases fly to the Larch and lay their eggs on the needles; while in other cases they do not migrate, but seat themselves on the needles of the Spruce in the neighbourhood of the open galls. I have found both types of ALATAE on the Larch needles in a free state, and have confirmed the observations by experimental infection of young Larch trees in the laboratory. As mentioned, however, in the note on page 125, the mere laying of eggs on any tree is not sufficient proof that that tree is the intermediate host, as Cholodkovsky found that the insects laid their eggs whether seated on the right tree or not. I

have, however, made no further attempts to follow the fate of the offspring on the intermediate host, and the inclusion of figures 4, 11/13 and 16/18 in the cycles of *Ch. strobilobius* and *abietis* respectively rests solely on morphological grounds, and I have not traced the descent direct from a FUNDATRIX on the Spruce.

The insects and galls figured in the following plates were all collected either in the Botanic Gardens, Cambridge, or in my own garden at Royston.

Ch. abietis (or *viridis*). Pl. viii, Figs. 1, 2, 7, 11, 12 and 13. Pl. ix, Figs. 14, 15, 22 and 23.

To which of these two species the insects figured belong, I am unable to decide. The differences between the two are exceedingly minute, as apart from colour and size, the only definite morphological distinction seems to lie in the comparative length of the antennal "joints." In the matter of colour the FUNDATRICES I have examined vary from dark green to light greenish-yellow, and the same insect may show any shade of colour between these two at different stages of growth. I have never noticed anything sufficiently definite in this respect to enable me to distinguish a green or a yellow breed. To judge by the structure of the antennae shown in Fig. 23, which were drawn with a camera lucida, the species should be *Ch. viridis*, since the third "joint" is longer than the fourth. But *Ch. viridis* is stated to be an invariable migratory species, while *Ch. abietis*, on the other hand, never migrates. Now the insects to which these antennae belonged were taken at Royston, and here there are no Larches anywhere near enough to render migration possible. I have, moreover, found ALATAE identical with the above laying their eggs on the needles of the Spruce close to the open galls, so that on this ground the species should be *Ch. abietis*.

In Fig. 7 I have only shown a shoot which is partially galled, but instances of the entire shoot becoming modified into a gall are not infrequent.

Ch. strobilobius (or *lapponicus*). Pl. viii, Figs. 3, 4 and 8. Pl. ix, Figs. 14, 16, 17, 18, 19, 21 and 24.

Here it is even more difficult to discriminate between these two species. Fig. 24 shows that in the ALATAE the fourth joint of the antennae is slightly longer than the third, and the fifth longer than the fourth, but since this structure is the same in both *Ch. strobilobius* and the *praecox* variety of *Ch. lapponicus*, it is no help. We are therefore reduced to a sole difference in habit for a distinction between the two species. If the ALATAE migrate, the species is *Ch. strobilobius*; if not, it is *Ch. lapponicus*. I know that in the Cambridge Botanic

Garden migration does in some cases occur, and I also know that in Royston it does not occur; therefore the Cambridge insects should be *Ch. strobilobius*, and the Royston insects *Ch. lapponicus*. The only way in which this point can be definitely settled is by carefully controlled breeding experiments.

Ch. orientalis (or *sibiricus*). Pl. viii, Figs. 5, 6, 9 and 10. Pl. ix, Figs. 20 and 25.

I only noticed these galls on the Oriental Spruce (*Picea orientalis*) for the first time in the middle of last summer. I have not yet found the FUNDATRIX in the *hibernating* condition, and on going through a few of the galls which I had preserved in spirit, I have been able to find very few of the adult FUNDATRICES, and only two of the cast larval skins showing the winter pattern of the glandular plates. One of these is shown in Fig. 5, and the structure of a thoracic plate, much enlarged, in Fig. 6. It will be seen that the median rows of plates are almost fused, a character which, following the tables, constitutes practically the only morphological difference between *Ch. orientalis* and *Ch. sibiricus*. Fig. 25 shows the top-shaped third and fourth "joints" of the antennae of the ALATAE. The galls varied considerably, and all degrees between the elongated type, shown in Fig. 10, and the more stunted form of Fig. 9 were to be found. The long form corresponds closely with the *Ch. sibiricus* galls described and figured by Cholodkovsky, but I think that the shape of the gall merely depends on the distance of the FUNDATRIX from the bud, and that all these galls were probably caused by the same species.

As regards the species of *Chermes* to be found on the intermediate hosts, Larch, Silver Fir and Pine, the only form which I have examined is the one mentioned as belonging to the cycle of *Ch. strobilobius* (Figs. 4, 16, 17 and 18), but I have noticed a second kind on the Larch, which differs from the first in being covered with "wool" and in laying bright green eggs. It probably belongs to the cycle of *Ch. viridis*. I have also seen *Chermes* insects on both the Silver Fir and Pine, so that it is quite likely that the third group, *Ch. coccineus*, etc., is also represented in this country.

B.—Species or Varieties.

The question now comes: are all these various forms of *Chermes* to be regarded as true species or merely varieties, and it is one which has been put to me more than once. While I do not feel in any way qualified to give a definite answer, it may perhaps suggest lines of future research if I discuss some of the difficulties which have arisen

in my mind with regard to the specific rank of the characters on which these species are based.

It may, I think, be safely affirmed that there is no other genus of insects which presents greater difficulties in the determination of its species than the genus *Chermes*.

The complicated cycle of development and want of regularity in their migratory habits, the close similarity between different species when adult, the polymorphism exhibited in different generations of the same species, and the microscopic nature of the distinguishing characters; all these combine to make the study of *Chermes* a task of exceptional difficulty. The fact that some years ago Cholodkovsky went so far as to suggest that perhaps all different forms of *Chermes* were merely varieties of one species—*Chermes coniferarum*, as he proposed to call it—is in itself sufficient illustration of this point. In my opinion the question is one which will not be definitely settled until each form of the genus has been repeatedly bred through the whole of its complicated cycle of generations on various species and varieties of both the primary and intermediate host-plants, with the strictest precautions to ensure the purity of each culture. I think it quite possible that, if pure cultures of this kind were made, the genus *Chermes* might prove to be an example of adaptive parasitism similar to that which is known to occur in the *Erysiphaceae* and other fungi, and that some of Cholodkovsky's species might turn out to be nothing more than biologic forms. It must not be inferred from this that Cholodkovsky has based his descriptions of the different species on mere examination of their morphological characters without attempting any breeding experiments at the same time. On the contrary, most of his information as to the migratory habits of those species which occur in Russia has been derived from breeding experiments and confirmed by synchronous observations of the insects in their free state. But, so far as I am aware, Cholodkovsky has published no detailed account of the methods pursued in these experiments, and we have no data from which we may judge for ourselves of the value of the results obtained. Information on many points would be most welcome. For instance, we do not know whether the whole cycle of each species has been bred from start to finish as the result of one infection, or whether the first year generations were reared at one time, and the second year generations from a fresh infection. Then was any attempt made to rear the same species on different species and varieties of host-plant? Were any precautions taken to isolate the different species and prevent all chance of migration interfering with the purity of the culture? It would also be interesting to know whether

a series of specimens was examined to see if any particular character was subject to variation before it was adopted as specific. In polymorphic insects like these one might expect to find considerable variation in such characters as the extent of fusion in the dorsal glandular plates, the arrangement of the pores on the plates, the coloration, the length of the "joints" of the antennae, etc.

But whether these various forms prove, on further examination, to be true species or merely varieties, we can in the meantime use the names given in the above tables without committing ourselves to a definite opinion one way or the other. The confusion in *Chermes* nomenclature is great enough already, and I do not propose to increase it by accepting this or rejecting that species, until the grounds for so doing rest upon such a firm basis as pure cultures alone can provide.

We will now pass on to consider the characters of (1) the galls, and (2) the insects.

I.—The Characters provided by the Galls.

(a) *The characters provided by the gall* consist of its size, shape, colour, and the presence or absence of normal shoot growth at its apex.

Examination of the tables will show that although there are eight species which produce galls on the Spruce, only three distinct types of galls can be recognized, viz.:—

- A.—The elongated cylindrical galls caused by *Ch. sibiricus* and *orientalis*. (Figs. 9 and 10).
- B.—The very stunted globular or cone-like galls caused by *Ch. strobilobius*, *lapponicus*, *coccineus*, and *funitectus*. (Fig. 8).
- C.—A type which is intermediate between A and B, and is caused by *Ch. viridis* and *abietis*. (Fig. 7).

There are, I think, strong grounds for believing that the development of gall-growth is caused by an injection of the insects. Since, however, we find that different species give rise to the same type of gall, it seems clear that the character of the gall is not due to any specific difference in the composition of the injection. On the contrary, I think that the composition of the injection is probably the same in all species of *Chermes*, and that the characters of the gall depend almost entirely on the ratio between the strength of the injection and the power of the embryonic tissue of the bud to resist it. We will first consider the factors which aid the buds to resist attack. It is hardly necessary to remind my readers of the monopodial growth of the Spruce, and of the fact that the terminal buds are larger and invariably exhibit a much stronger and quicker growth in spring than the lateral buds at the proximal end of the shoot. Consequently an

insect would have a much harder task to completely modify a terminal bud into a gall than if it selected a lateral bud lower down on the same shoot. A similar difference in strength exists between those buds of a tree which are fully exposed to light, and buds on branches growing in shaded situations, the latter being weakly, and much more easily influenced by the parasite. Again, there is a marked difference in the rate of growth. The terminal buds are the first to open, and the development of the shoots proceeds from above downwards. Between the terminal and the lowest buds of the same shoot there is often as much as a fortnight's difference in the time of casting the cap of winter bud scales; there is considerably more than this interval between the earliest and latest buds on the same tree, while between the earliest and latest buds of different trees growing in the same garden I noticed as great an interval as six weeks last spring.

Now my observations seem to show that so long as the bud remains closed the insect's influence is predominant, but that as soon as the shoot bursts from the bud scales it endeavours to resist the attack of the parasite. It follows that the power of a bud to resist the *Chermes* influence also depends in some measure on whether it opens early or late.

The strength of the injection, on the other hand, is also dependent on several circumstances. In the first place, its effect is stronger or weaker in proportion as the length of time during which it is acting on the unopen bud is longer or shorter. The explanation of this is found in the fact that the embryo shoot offers practically no resistance to the injection so long as it is enclosed in the winter bud scales. The reserve of food material stored up in the bud is converted to the insect's use, the tannin and resin canals disappear, and the chlorophyll is destroyed. All differentiation of the tissues disappears wherever the influence of the injection reaches, and a parenchymatous mass of thin-walled, greatly-distended cells, with vacuolated protoplasm and numerous grains of starch, is formed. But once the bud scales are thrown off, and the galled shoot emerges to the light, it endeavours to repair the ravages of the insect. The normal elements of the plant tissue reappear in abnormal situations, and we find chlorophyll, tannin and resin canals laid down once more, and the extent to which the shoot succeeds in resisting the gall influence may be more or less judged by the shade of green it assumes. We have seen that the rate of bud development varies considerably. The rate of development of the insects seems to vary in the same proportion, for their growth in spring apparently begins and keeps pace with that of the buds on which they are seated. The Larch, for example, puts forth its shoots

at least six weeks before the Spruce. Last spring the Larches in the Cambridge Botanic Gardens were quite green by 3rd April, and the *Ch. strobilobius*-COLONICI had in many cases completed their moults and commenced to lay eggs at that date. The Spruce Firs in the same gardens did not reach the equivalent stage of shoot growth until the third week in May, and I even found some buds still unopened as late as the first week in June. The *Ch. strobilobius*-FUNDATRICES on the Spruce were equally late in development, and I was unable to find any which had reached the stage of egg-laying until 24th April, and the majority of the insects did not begin to lay eggs till the first week in May. I believe the same difference in the rate of development will be found between those insects seated on early and those on late Spruce buds, but my observations on this point last spring were interfered with by the majority of the insects marked for observation being killed by frosts or eaten by spiders or tits.

It follows from the above remarks that in the case of buds which develop slowly the injection continues to act for a longer time on non-resistant embryonic tissue than is the case in buds which develop quickly.

Even supposing the amount of the injection to be the same in both buds, it is, I think, reasonable to suppose that its influence would have a less deleterious effect on the early bud than on the late bud. But Cholodkovsky has pointed out in the case of the gall inhabitants that their size depends upon the length of time they feed in the gall. Thus on page 5 he says:—"Überhaupt ist die Grösse der Geflügelten (wie auch bei andern Chermes-Arten) sehr veränderlich, was vorzugsweise von der ungleichen Ernährung abzuhängen scheint, indem die aus den ersten Eiern ausgeschlüpften Larven sich besser und länger nähren, als die jüngeren."

I have never examined this point, but probably there is a similar difference in size between the early and late FUNDATRICES, in which case the quantity of fluid injected by the larger FUNDATRICES would probably exceed that injected by the smaller FUNDATRICES, and this of course affects the extent of modification.

The quantity of the injection further depends upon the number of *Chermes* insects which attack the same bud. It is no uncommon thing to find buds literally studded with the insects, and I have sometimes counted as many as twenty *Ch. strobilobius* on the same bud. Such a bud, of course, will form a complete gall and show no sign of any normal growth.

Another factor upon which the strength of the injection depends is the distance it has to travel before reaching the embryonic tissue,

on which alone it can act. It is reasonable to suppose that the strength of the fluid becomes dissipated in the tissues through which it passes before reaching a bud, when it is injected an inch or so below that bud, as in *Ch. sibiricus* and *orientalis* (Figs. 9 and 10), and that it is more concentrated when injected directly into the bud itself, as in the *Ch. strobilobius* group (Figs. 14 and 8). Examination of the three types of gall, and of the positions occupied by the FUNDATRICES in each case confirms this supposition, and we find that the further the insects are seated from the buds, the less influence do they exert on the shoot, and, conversely, the nearer they are seated, the more complete is the modification into a gall.

To sum up the foregoing, the strength of the buds depends chiefly on:—

- (a) Their position on the shoot, since terminal buds are stronger than lateral buds.
- (b) Their situation in relation to light, since buds fully exposed to light are stronger than those grown in shade.
- (c) Their rate of development in spring, since the earlier the shoot emerges, the sooner is the work of assimilation, and thereby resistance to the influence of the gall insect begun.

The strength of the injection, on the other hand, depends on:—

- (a) The length of time it is able to operate on the non-resistant embryonic tissue before the opening of the bud.
- (b) The quantity of the injection, which is probably greater in the case of slow-growing insects than in those which develop rapidly, and is certainly greater when the insects on a bud are numerous than when they are few.
- (c) The distance of the puncture through which the fluid is injected from the bud on which it acts, since if injected at a point some distance below the bud, its strength is probably reduced in passing through other tissues; while if injected directly into the bud, its strength is likely to be more concentrated.

The size, shape and colour of the gall, and the extent of normal growth remaining on the shoot attacked, are then merely to be regarded as indices expressive of the ratio between the strength of the bud and the strength of the injection, and cannot, in my opinion, be used as specific characters.

(b) *Position of the hibernating Fundatrices in relation to the buds.*

The only thing that can be said is that the sum of the gall characters mentioned above is more or less of a guide to tell one the position occupied by the FUNDATRIX in relation to the bud. Reference

to the tables shows that a certain degree of uniformity is said to be noticeable in the habits of the different species as regards the position selected:—

Thus *Ch. sibiricus* and *orientalis* usually seat themselves on the stem below the bud. (Figs. 9 and 10).

Ch. viridis and *abietis* are usually found on the neck of the bud. (Fig. 14, *b*).

Ch. strobilobius, *lapponicus*, *coccineus*, and *funitectus* hibernate on the bud itself. (Fig. 14, *a*).

Cholodkovsky points out that in *Ch. sibiricus* the position varies, the insects being sometimes seated quite near a bud, and at other times some distance below it, and that the character of the gall differs accordingly. I have noticed the same variation in *Ch. orientalis* (Figs. 9 and 10). In *Ch. strobilobius* (Fig. 14, *b*) there is a remarkable degree of uniformity in this respect, and I have never found this species in any other position than on the bud, though sometimes it is seated so low down on the bud as to almost encroach on the territory of *Ch. viridis* (*abietis*). This last species is also fairly constant in selecting a position quite near to a bud, but although I have never found it *on* the bud, it is not necessarily on the neck, but may occur on the stem a short distance below a bud.

The characters of the gall, then, although indicative of the position occupied by the FUNDATRIX, can only serve as a rough guide to the species of insect, since the same position is selected by more than one species, and even in the same species the position is subject to more or less variation. The matter is, moreover, complicated by the fact that a single gall is not uncommonly due to the combined attack of two species on the same bud, as shown in Fig. 14.

(*c*) *Dehiscence of the Galls*.—It will be noticed that the time when this occurs is stated rather precisely for each species, and from the manner in which Cholodkovsky writes about it, I gather that he regards the time of gall opening as to some extent constituting a definite specific character. The importance of keeping a record of the time of gall dehiscence has not previously occurred to me, but I hope to make notes on this point during the coming summer. Of the two species, *Ch. strobilobius* and *Ch. abietis* (or *viridis* ?), it is certainly true that numbers of *strobilobius*-galls open as early as June, and that *abietis*-galls seem as a rule to ripen later. But without further examination I should hesitate to say that *ALL strobilobius*-galls open early, and *ALL abietis*-galls late, and it is difficult to understand how there can be such regularity. The dehiscence of the gall is in reality due to the death of the cell protoplasm, which results in the shrinking of the

gall tissues, and consequently in the opening of the chambers. The time required to kill the protoplasm must again depend upon the ratio between the respective strengths of the bud and the injection. We have already seen that there is a marked difference between various buds in their strength and rate of development. It follows that, unless each *Chermes* species selects buds of approximately equal strength and rate of growth, the insects of any one species, whether seated on strong and quick growing, or on weak and slow growing buds, are nevertheless able to force the shoots to develop into galls in such a manner that all the galls of that species shall reach maturity and dehisce at approximately the same period. A weak bud is of course more rapidly killed than a strong one, and the fact that *Ch. strobilobius* more frequently selects weak buds probably accounts for the fact that so many of its galls open early. But although this species exhibits a preference for weak buds, I have also found it on buds of average strength. I have also observed unopened galls which I believed to be due to *Ch. strobilobius* quite late in the year, but as I did not examine the insects microscopically I cannot speak definitely as to the species. As regards *Ch. abietis*, this species certainly attacks both weak and strong buds without exhibiting any particular preference for either, and we ought therefore, according to this theory, to find its galls opening both early and late. I hope to clear up this doubt next summer.

II.—The Characters provided by the Insects.

The main features used to distinguish the species are as follows:—Colour, shape, size, length of the proboscis loop, quality and quantity of the "wool," structure and arrangement of the glandular epidermal plates, and in the winged generations the nervation of the wings, and the length of the three terminal "joints" of the antennae.

First, as regards the colour of the insects; examination of almost any species in the tables will show that this is a character upon which very little reliance can be placed, as the same colour is rarely maintained in every stage of the insect's existence. A list of the colours found in the cycle of the four species which differ most from each other in the sum of all their characters will show this clearly.

Ch. viridis.—Dark green, light green, greenish-yellow, reddish, yellowish-red, yellowish, sulphur yellow; Eggs: green, dark green, greenish-yellow, yellow.

Ch. strobilobius.—Black, greenish-yellow, greenish-brown, reddish, reddish-brown, dark red, greenish-grey, chocolate brown, grey, dark brown, olive green, reddish-yellow. Eggs:

yellow, greenish yellow, yellowish-red, greenish, greenish-brown, yellowish-green, reddish.

Ch. coccineus.—Black, bluish-brown, greyish-brown, reddish, dark red, reddish-brown, dark violet, reddish-violet, dark grey. Eggs: reddish-brown, reddish-yellow, dark green.

Ch. sibiricus.—Chocolate brown, yellowish-brown, dark red, yellowish-grey, yellow, reddish, dark green. Eggs: brownish-yellow, reddish-yellow, yellow.

The shape and size of these insects are so similar throughout the genus that any minute differences there may be are too indefinite to attach any importance to them. The size varies considerably in the same species in individuals of the same generations, and depends on the duration of feeding during the larval stage, and this might easily account for the difference in shape, which can only be expressed by the words "more slender."

The length of the proboscis loop in the wingless generations seems to me a character which should be carefully examined in a large number of examples before any reliance can be attached to its invariability. It depends upon the habit that the insects when not engaged in sucking coil their long proboscides into an 8-shaped loop, which is carried below the abdomen. Whether one end of the loop reaches the hinder end of the abdomen or not, probably depends on the length of the proboscis, and it is quite possible that this may be subject to considerable variation. On examining the tables we find that there is such a variation between the *Fundatrices* and the *Colonici* of the same species (*Ch. viridis*, *strobilobius*, etc.), while in *Ch. lapponicus* insects with short loops and others with long loops occur in the same generation. Even if the proboscides were all the same length it is improbable that all the insects of the same species would coil them up to exactly the same length.

The structure of the glandular plates of the hibernating larvae and the nature of the "wool" which covers them during the winter are the most distinctive of all the characters. In the hibernating condition the larvae of the different species can be easily recognized with the help of a lens, but soon after they awaken in spring the winter skin is cast, and not only does the "wool" now excreted differ between the species in much less degree than that carried by the insects in winter, but the structure of the skin changes after each moult, and is more or less similar in all species. The insects all become swollen into ovoid bodies, and the glandular plates are replaced by warts bearing facets, so that the only way in which one can be absolutely certain of the species in summer is by finding the cast winter skin in the clump of "wool."

But even these characters of the glandular plates and the "wool" are not so satisfactory as at first appears. They are, in the first place, larval not adult characters, and when we find that there are certain differences between the plates of the FUNDATRIX and COLONICI generations of the same species, and that one generation excretes "wool," while another does not—e.g., *Ch. strobilobius*, *coccineus*, etc., doubts arise in the mind as to how far we may rely on these characters. They are, however, most useful in that they provide one with a fixed starting point.

The position that the secondary nervure of the hind wing occupies in relation to the longitudinal nervure does not carry us very far. As far as my observations go it certainly makes about a right angle in *Ch. abietis* (Fig. 22), while in *Ch. strobilobius* (Fig. 21) and *Ch. orientalis* (Fig. 20) it forms an acute angle with the longitudinal nervure. There are other species as well in which this secondary nervure is placed obliquely, so that the right-angled position merely enables *Ch. abietis* (*viridis*) to be distinguished.

The comparative length of the last three "joints" of the antennae is a character I have only examined in a very few cases, but its importance is evident on reference to the tables, as it is practically the only definite feature by which the different species can be recognized in the winged generation. It is therefore most necessary to know whether the character can be absolutely relied on, or whether it is subject to variation. Cholodkovsky tells us (page 6) that these three "joints" are in reality only pseudo-joints, caused by two constrictions dividing the long terminal joint of the antennae into three apparent segments. If this is the case, such pseudo-joints might, one would think, be more subject to variation in the matter of length than the true joints. Now in *Ch. viridis* such a variation is stated to occur, as the following quotation from page 6 shows:—"Die Fühler sind fünfgliedrig, oder richtiger, erscheinen als solche; die beiden ersten (basalen) Glieder sind sehr kurz, das dritte länger als das vierte und dem fünften ungefähr gleich. Diese Verhältnisse sind aber etwas veränderlich; die Glieder 3-5 können nämlich alle annähernd gleich lang sein oder es erscheint das vierte sogar etwas länger als das dritte."

In *Ch. lapponicus* again the length of the fourth "joint" differs in the two varieties, being longer than the third in *var. praecox*, and shorter than the third in *var. tardus*. Seeing, then, that this character is subject to variation in two species, it seems remarkable that in other species the comparative length is apparently invariable, and can be ranked as a specific character. It would be interesting to know whether any series of measurements of the antennal "joints" of a number of

insects of each species was made before adopting the character as specific.

The above remarks will, I think, enable the reader to realize some of the questions which require an answer before the exact limits of each *Chermes* species can be absolutely defined, and I further hope that they may suggest a line of useful research to entomologists in this country.

EXPLANATION OF PLATES VIII AND IX,

Illustrating Mr. E. R. Burdon's paper on the European Species of the Genus *Chermes*.

PLATE VIII.

- Fig. 1.—*Chermes abietis* (or *viridis*). Fundatrix generation; hibernating larva after removal of the "wool," shewing the 6 longitudinal rows of glandular plates each with 4 or 5 pores. Pr. proboscis. \times about 125.
- Fig. 2.—Portion of the first two abdominal segments of *Ch. abietis* (or *viridis*) shewing the pattern of the pores on the plates, and one or two "wool" fibres projecting from the pores. Much enlarged.
- Fig. 3.—*Ch. strobilobius* (or *lapponicus*). Fundatrix generation; hibernating larva. Glandular plates, each with one double contoured pore, from which a single long fibre is excreted. \times about 125.
- Fig. 4.—*Ch. strobilobius*. Colonici generation; hibernating larva from the Larch. Glandular plates with only one pore as in Fundatrix generation, but plates more or less fused on abdominal segments, and pores very small and with single contours. "Wool" absent. \times about 125.
- Fig. 5.—*Ch. orientalis*. Fundatrix generation; cast skin of a hibernating larva from *Picea orientalis*. Median rows of glandular plates practically fused to form a single plate, and plates divided into regular polygonal areas. (The legs have been omitted for the sake of clearness). \times about 125.
- Fig. 6.—A thoracic plate from the cast winter skin of *Ch. orientalis*, shewing the polygonal markings. Much enlarged.
- Fig. 7.—*Ch. abietis* (or *viridis*). Shoot of *Picea excelsa* partially modified into a gall.
- Fig. 8.—*Ch. strobilobius* (or *lapponicus*)-gall. Shoot of *Picea excelsa* completely modified into a gall.
- Fig. 9.—*Ch. orientalis*-gall. Shoot of *Picea orientalis* completely modified into a gall.

Fig. 10.—*Ch. orientalis*-gall. Shoot of *Picea orientalis* slightly modified into a gall.

In above figures F = Fundatrix.

Fig. 11.—Female of Generation V. (Sexuales). Dorsal aspect. This probably belongs to the cycle of *Ch. abietis* (or *viridis*). The males are very similar, but have longer legs and more slender bodies with pointed abdomina.

Fig. 12.—Ventral aspect of same, shewing origin of proboscis and the sheath in which it lies.

Fig. 13.—Antenna of same, shewing the 4 "joints."

PLATE IX.

Fig. 14.—(a) *Ch. strobilobius* (or *lapponicus*). Larval Fundatrices.

(b) *Ch. abietis* (or *viridis*). ditto
seated on buds of *Picea excelsa* in winter.

Fig. 15.—L.S. through a lateral bud, shewing a Fundatrix of *Ch. abietis* at base, the course of its proboscis, and the commencement of gall formation.

Fig. 16.—One-year old Larch shoot in winter, with hibernating Colonici of *Ch. strobilobius*. Notice the absence of "wool."

Fig. 17.—Three-year old Larch shoot at the beginning of April, with Colonici of *Ch. strobilobius*. The insects in some cases have reached maturity and commenced to lay eggs.

Fig. 18.—Larch shoot in May, with Colonici, Exsules and Sexuparae of *Ch. strobilobius*. The needles are often bent at the point attacked.

Fig. 19.—*Ch. strobilobius* (or *lapponicus*)-Alatae on the needles of the Spruce.

Fig. 20.—*Ch. orientalis*-Alatae, shewing the secondary nervure of the posterior wing placed obliquely to the longitudinal nervure. The line above the latter merely represents a fold or thickening of the wing.

Fig. 21.—Wings of *Ch. strobilobius* (or *lapponicus*). Alatae, shewing oblique position of the secondary nervure of the posterior wing.

Fig. 22.—Wings of *Ch. abietis* (or *viridis*), shewing the secondary nervure placed at right angles to the longitudinal nervure of the posterior wing. More enlarged than Fig. 21.

Fig. 23.*—Antennae of three specimens of *Ch. abietis* (or *viridis*)-Alatae, shewing the 3rd "joint" longer than the 4th.

Fig. 24.*—Antennae of three specimens of *Ch. strobilobius* (or *lapponicus*)-Alatae, shewing 4th "joint" to be longer than 3rd, and 5th longer than 4th.

Fig. 25.*—Antennae of three specimens of *Ch. orientalis* (or *sibiricus*)-Alatae, shewing "joints" 3 and 4 to be more or less top-shaped.

* Figs. 23, 24 and 25 are all drawn with a camera lucida to the same magnification.

Figs. 4 and 14 to 18 are copied from the *Gardener's Chronicle* by the courtesy of the Editor.

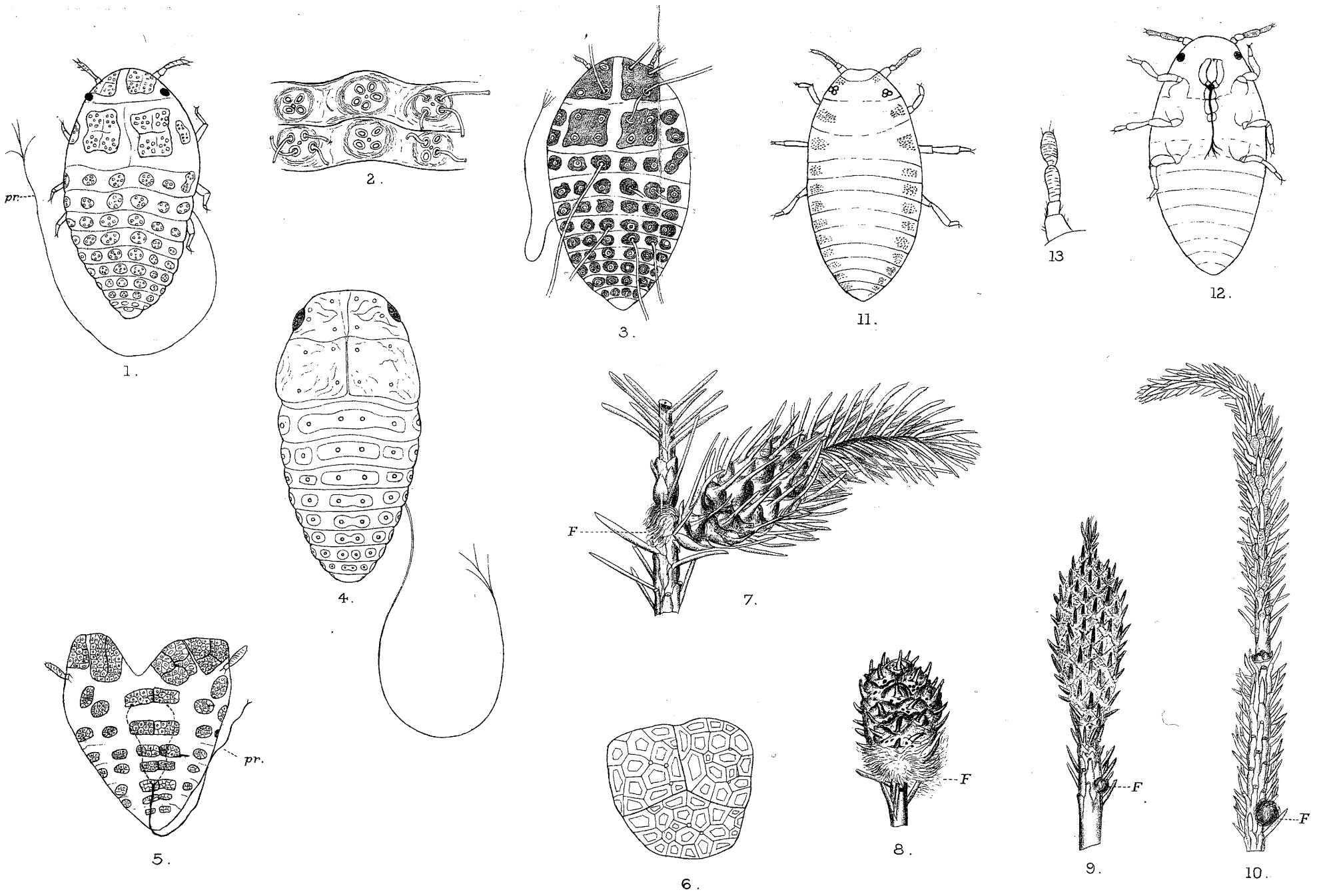

EUROPEAN SPECIES OF CHERMES.

Huth, Lith^r London

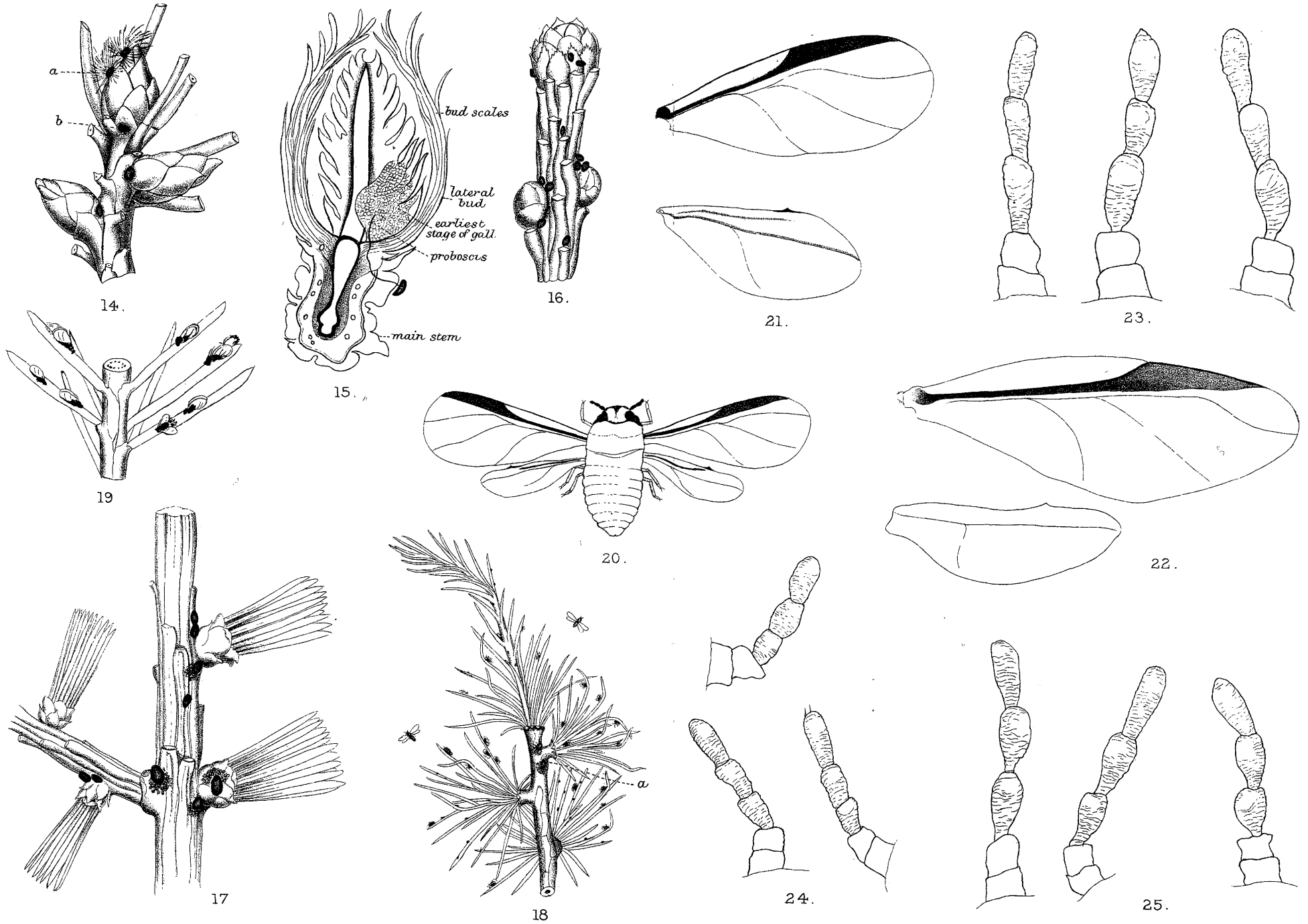

Huth, Lith. London.

EUROPEAN SPECIES OF CHERMES.

ON THE STRUCTURAL CHARACTERS OF THREE SPECIES
OF COCCIDAE AFFECTING COCOA, RUBBER, AND
OTHER PLANTS IN WESTERN AFRICA.

By

ROBERT NEWSTEAD, A.L.S., Etc.,

The School of Tropical Medicine, The University, Liverpool.

WITH THREE TEXT FIGURES.

DURING the last two years several interesting collections of injurious insects from Western Africa have been placed at my disposal for verification and report, the larger portion of which belong to the family *Coccidae*, but there are also several other Orders of insects represented, and efforts are being made to publish a descriptive account of these insects, together with the available information as to the nature and extent of the injury caused by them. Unfortunately the time at my disposal for such extraordinary work is very limited, and it may be some time before the work will be completed. Meanwhile there are matters regarding some of the *Coccidae* which I wish to deal with at once, and these will form the subject matter of this communication. I wish, however, to offer my sincere thanks to Dr. L. Reh, of the Natural History Museum, Hamburg, for the material collected in the Cameroons; and to my colleague, Dr. Slater Jackson, for the great pains he has taken to collect specimens during his frequent but short visits to the West Coast of Africa.

***Stictococcus sjöstedti*,¹ Ckll.**

This curious insect was described by Cockerell in 1903 from material collected in the Cameroons by Dr. Sjöstedt, to whom the insect is dedicated. Cockerell was not, apparently, furnished with any particulars as regards the food-plant, and I can find no reference to such in any recent publication. In 1904 I received through Dr. Reh, of Hamburg, a number of specimens of this insect which were col-

¹ Canadian Entom., 1903, vol. xxx, p. 64.

[JOURN. ECON. BIOL., 1908, vol. ii, No. 4.]

lected by Dr. Winkler in the Botanic Gardens at Victoria, Cameroon, with the note that they were found infesting the young fruit of the Cocoa (*Theobroma cacao*), and were, for the most part, attached to the stalks of the pods,¹ sometimes completely covering them. Since that time Dr. Jackson has collected specimens on Cocoa and Rubber at Gaboon, in 1907; on Cocoa at Aburi, 10, iv. 06; on *Coffea*, sp. at Warri, viii. 07; and on an unknown plant at Koko Beach (Benin River), where it was extremely abundant, and was found infesting the small branches of some very tall trees. This insect is therefore fairly widely distributed along the west coast, and will in all probability be found in other localities where the cocoa is under cultivation, and also on other plants.

Cockerell (*l.c.*) established the genus *Stictococcus* for the inclusion of *S. sjöstedti*, and until quite recently the genus was a monotypic one. About a week since I described a second species,² from Kilimanjaro, E. Africa, which, strange to say, was also discovered by Dr. Sjöstedt, of the Zoological Museum, Stockholm, in 1905.

With such an abundance of material I have been enabled to make an extended examination of the female in all stages, and also to prepare the accompanying drawings illustrating the anatomical characters of this insect, none having hitherto been published. At the same time I find it necessary to enter more fully into the structural details than Cockerell has done, to somewhat extend the generic characters, and clear up some important discrepancies which I find on comparing my examples with the existing description. I find it necessary also to remove the insect from the position it now occupies in the classification of the *Coccidae*.

Genus *Stictococcus*, Ckll.

Canad. Ent., 1903, vol. xxxv, p. 64.

Female.—Anal orifice in the middle of the back, enclosed by a pair of transverse setiferous sclerites, not connected with the hind margin by a slit or groove. Legs and antennae present, the latter of 4-6 segments. Dorsum with or without secretionary covering; smooth or spinose.

¹ Lord Mountmorres in his paper on "Maize, Cocoa and Rubber" (Liverpool University: Institute of Commercial Research in the Tropics, p. 22, 1907), says that these coccids "form scales all over the pods, and the red ants which live on these trees (cocoa) keep them in check." The coccid in question is *S. sjöstedti*. R.N.

² *Stictococcus multispinosus*, n. sp., distinguished by the dorsum being covered with long barbed spines, and a white mealy secretion divided by a broad marginal, and a medial black band. R.N.

Larva with a spinose dorsum and long hairs at the margins and abdominal extremity. Anal orifice setiferous. Antennae of four segments. Anal lobes obsolete.

The italics are mine; the remainder from Cockerell's description (*l.c.*).

The characters of the female antennae and also the dorsum are based upon the two known species; the remaining portion of the diagnosis upon *S. sjöstedti* alone.

In addition to the principal anatomical details which may be considered of generic importance there is also present on the venter a transverse slit¹ or fold, which leads apparently to a small pouch, as in certain Monophlebids, but owing to the nature of the chitin (no sections were cut) it is difficult, indeed almost impossible, to determine its true character. Cockerell described this insect as an aberrant genus of *Lecaniinae*, and Sanders² includes it in the same sub-family under the new name *Coccinae*. It seems to me, however, that the total absence of anal lobes, in all stages, precludes its retention in this group; though for the moment I am doubtful as to which of all the allied families it belongs; but provisionally I would place it after *Zylococcus*, in the sub-family *Margarodinae*, though the setiferous anal ring is, as far as I can trace, abnormal.

Stictococcus sjöstedti, Ckll.

Female adult.—Cockerell (*l.c.*) has fully described the external features of this insect; but there are some structural details which he has overlooked, and others that require elucidation. The antennae (Fig. 1) are as already described, but I find one or two faintly knobbed hairs on the apical segment. Legs about as long as the antennae; digitules to tarsi, normal. Mentum monomerous. Anal orifice (Fig. A 2) closed by two chitinised plates or sclerites, placed transversely or one in front of the other, the upper plate having a row of 6-7 spinose hairs and a pair of longer and stouter ones anterior to them; the lower plate has apparently six³; these plates are not, I think, analogous to the anal plates (modified anal lobes) in the *Lecaniinae*, as they are, as already stated, arranged transversely, though their function may be similar. Posterior pair of spiracles with *two channels* leading from them to the margin; anterior pair with one; spinnerets circular. Margin with a continuous series of closely arranged spines, one set bluntly

¹ Cockerell also mentions this organ.

² Catalogue of recently described *Coccidae*, Washington, 1906, p. 7.

³ *S. multispinosus* has a similar arrangement, but the plates have fewer hairs.

serrated (Fig. A 3 *a*), the other curved and sharply serrated (Fig. A 3 *b*); and at long intervals between them are some single and very long stiff hairs (Fig. A 3 *c*). Dorsum with minute spines and small tubular spinnerets. Dorsal glands (Fig. A 4) large, irregular in form, but shaped somewhat like a campanulate flower, with the outer edge deeply and regularly divided, the chitin surrounding these organs much thickened; they occupy the positions indicated externally by the deep punctures which are filled with cereous matter.

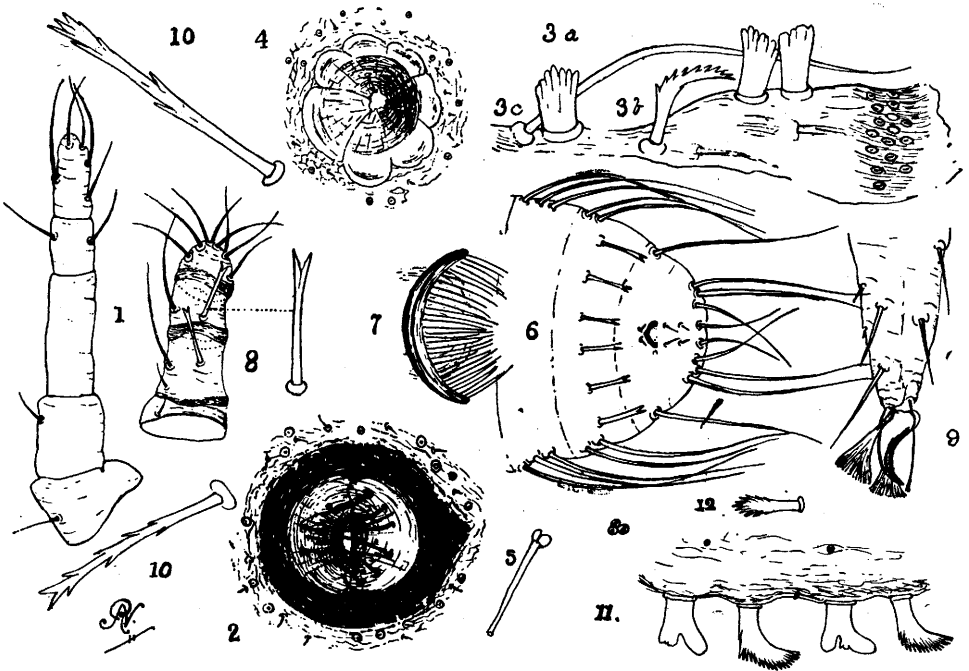

Fig. A.—1. Antenna of adult female; 2. anal orifice of adult female; 3 *a-c*. marginal spines of adult female; 4. dorsal glands of adult female; 5. tubular spinneret; 6. anal extremity of abdomen of larva; 7. anal orifice of larva; 8. antenna of larva; 9. tarsus of larva; 10 (*bis*). serrated spines; 11. marginal spines of second stage female; 12. submarginal spine of ditto. All greatly enlarged.

Ventral derm with many short spines, those at the margin much the longest, forming an almost complete series just below the marginal spines; spinnerets circular, scattered, except near the margin, where they form little groups of three.

Female third stage.—Ovate, flat, dusky ochreous. Antennae of only example seen asymmetrical; one of five segments, the other of six; relative length of segments similar to those in the adult. Legs as in the adult. Structure and arrangement of the marginal spines as

in the adult, but the broad digitate forms are placed much more closely together, so that, in some places, they slightly overlap each other. Derm above almost covered with circular spinnerets and minute spines. Anal orifice resembling that of the adult, and, like it, also placed in the centre of the dorsum.

Female second stage.—Very short ovate, or sub-circular. Antennae of five or six segments, short; possessing divided spines as in the larva. Margin with a fringe of two forms of spines (Fig. A 11), arranged alternately, one form being dilated and curved backwards with the outer edge finely serrate, the other with two or more lobate extensions: there is also a sub-marginal series of smaller serrated spines (Fig. A 12). Anal orifice with the outer ring, as in the adult; within the ring is the true orifice, which has its distal or anterior half chitinised, and bears on its inner edge a fringe of fine and closely-set hairs (? 50), pointing backwards and partly closing the orifice; attached to the outer margin of the inner ring, laterally, are four (two on either side) long spines, and above these, between the true orifice, on the clear and thinner derm, anteriorly, are two more similar but much longer spines, which reach beyond the posterior margin of the outer ring.

Embryo larva (taken from the body of the parent) elongate. Dorsum with six rows of spines (Fig. A 6) dilated and divided at the ends; ventrally there are also two rows of divided spines similar to those on the dorsum, but smaller; margin of abdominal segments (see Fig. A 6) with long spinose hairs. Anal segment (Fig. A 6) without lobes. Anal orifice (Fig. A 7) with a semicircle of chitin, the inner or lower edge of which is fringed with long and extremely delicate hairs.¹ Antennae (Fig. A 8) of four segments, of which the second and third are nearly equal in length and much the longest; the first and fourth segments together equalling the third in length; articulations of all the segments are indicated by strongly chitinised bands; there are two or three short hairs on the first and second segments, one or two very long spinose hairs on the second and third, each segment also bears a single long spine slightly dilated and divided at the end; and the apical one bears six or seven long spinose hairs. Rostrum and monomerous mentum minute; legs rather long, stout, spinose; digitules to tarsi absent; those of the claw (Fig. A 9) broadly dilated with fine lines radiating from its base; claw strong, with a deep ventral channel, in which lies a knobbed hair of the form usually met with on the tarsi of most members of the *Coccidae*.

¹ Visible only under a $\frac{1}{12}$ oil immersion lens.

Cockerell's description of the larva applies undoubtedly to the second stage female, and is, so far as it goes, accurate, though much too brief and incomplete.

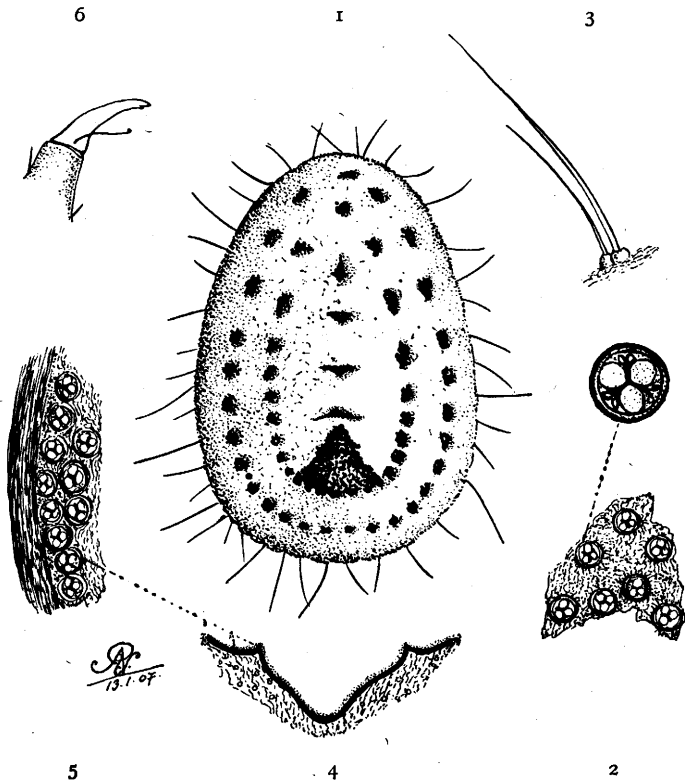

Fig. B.—1. Adult female, dorsal; 2. spinnerets of dorsum; 3. double hairs of do.; 4. margin of ? marsupium; 5. spinnerets on inner edge of do.; 6. claw of the larva. All greatly enlarged.

Palaeococcus theobromae. n. sp.

Adult Female.—(Fig. B 1) ovate, but widened posteriorly. Dorsum almost flat; covered with densely felted and finely pitted bright sulphur-yellow secretion, with the exception of a double series of spots, following the contour of the margin, and a median series more irregular in outline, all of which appear as blackish depressions in the secretion. Margin crenulated, especially beneath, with numerous long outstanding hairs. Antennae not very highly chitinised, of nine segments, tapering slightly as far as the 8th inclusive; 9th much broader than the preceding segment, and is also the longest; 2nd and 3rd equal, cylindrical, but shorter than the 9th; 4th to 8th, inclusive,

subequal, sides curved; all the segments with spinose hairs. Dorsal epidermis almost covered with large circular spinnerets (Fig. B 2) having three large circular pores (rarely four), and in the space between them, near the periphery, two minute ones. Hairs of the dorsum (Fig. B 3), especially in the region of the antennae, arranged in pairs, one long and one short. Spinnerets of the venter smaller than those on the dorsum, there are also a few minute hairs. Margin of vaginal orifice (? marsupium) (Fig. 4) broadly V-shaped, with the tips curved outwards and upwards; inner margin covered with spinnerets (Fig. B 5), which before maceration is seen to be covered with white secretion.

Length, 3.50-4.25 mm.

Female Second Stage.—Antennae of six segments; marginal hairs much longer at the posterior extremity of the abdomen than in the adult.

Larva resembles those of the genus *Icerya* in the arrangement of the marginal hairs. Mentum biarticulate. Claws bifid (Fig. B 6); lower digitules knobbed. Only one example obtained, and this is in many ways imperfect, the antennae being broken, so that it is impossible to fully describe it.

Habitat.—On the leaves of Cultivated Cocoa (*Cacao*, sp.); Calabar, W. Africa; 1.07. Collected by Dr. Slater Jackson.

This is a very striking insect when perfect; but the old examples become covered with a black fungoid growth, so that all trace of the secretory covering becomes obliterated. No ovisac is formed, but the ova or larvae may be retained within the large pouch or opening on the venter. It appears to be quite distinct, and is altogether an interesting insect. Crowded together along the mid-rib of the leaf were large numbers of the empty skins of the young females, with here and there an old adult female wedged in between them. Dr. Jackson informs me that the attacked leaves become sickly and yellowish in colour; but I have no information as to the prevalence of this insect, or of the extent of the injury caused by it.

***Pulvinaria jacksoni*, n. sp.**

Ovisac from two and a half¹ to seven times the length of the female; breadth equal to the width of the insect; low convex sides parallel; closely felted, tough and web-like in texture.

Length, 16.75-42 mm.

Adult Female.—Dried examples sienna-brown or dull ochreous; the pale examples with yellowish mottlings indicating the position

¹These are evidently incomplete.

of the derm-cells. Form normal. Antennae (Fig. C 1) of eight segments, the third being much the longest; last four subequal; there is a very long hair on the third and fifth, the one on the former the longest. Legs (Fig. C 2) stout; trochanter about one-third the length of the femur, with a very long apical hair; digitules to claws and tarsi normal. Derm with very small inconspicuous glands. Marginal spines short, closely set, truncate, the ends often notched. Stigmatic cleft (Fig. C 3) with pointed spines and two large tubercles, the latter longer than the longest spine.

Length, 6.25-7 mm.; width, 4-4.75 mm.

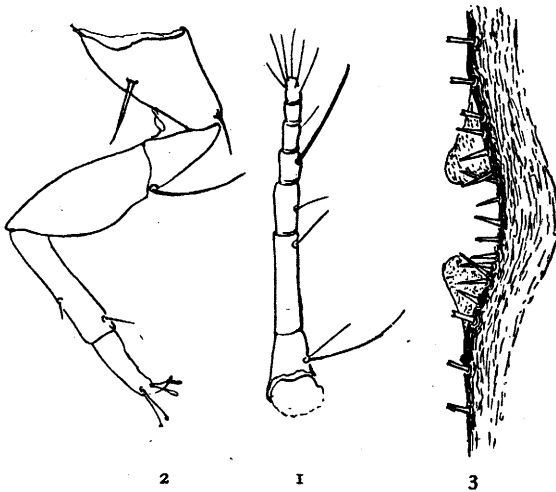

Fig. C.—1. Antenna of adult female; 2. leg of adult female; 3. stigmatic cleft with tubercles and spines, of ditto. All greatly enlarged.

Male puparium, white stained with brown. Normal in shape, but thick, and unusually wax-like in appearance; dorsal plate with one large central, white, wax-like felted spot and several (3-4) brownish tubercles immediately beyond it.

Length, 2.25 mm.

Male unknown.

Habitat.—On Cacao, Royal Botanic Gardens, Calabar (February 1.07); and on *Ficus*, sp., at Dakar (October 3.07).

Allied to *Pulvinaria maxima*, Green; but may be readily distinguished by the unusual length and texture of the ovisac; by the presence of two large tubercles at the margin of the stigmatic clefts, and the great length of the trochantae.

The insect, for the most part, fixes itself upon the smaller branches of its food-plant, and as the ovisacs are only slightly raised above the bark they appear, even on close examination, remarkably like a white fungoid growth. The resemblance is so striking that I was at first completely deceived. Dr. Jackson informs me that he also, at first, mistook the ovisacs for white mould. Only three examples were found on the Cacao, but they were abundant on *Ficus*. Many of the ovisacs had been partly destroyed by predaceous insects, presumably ; and Dr. Jackson informs me that on paying a second visit to the *Ficus* tree, after an interval of a few weeks, he found that all the coccids had disappeared. The colonies were visited by numbers of ants ; but no coccinellids or other predaceous insects were seen near the coccids.

REVIEWS AND CURRENT LITERATURE.

I.—GENERAL SUBJECT.

Burkett, C. W.—Soils, their Properties, Improvement, Management, and the Problems of Crop Growing and Crop Feeding. Pp. x + 303, 129 text figs. New York: Orange Judd Company. London: Kegan Paul, Trench, Trübner and Co., Ltd., 1907. Price 6s. net.

The agriculturists of no country have so fully realised the importance of the study of the soil as those of America. The more they know about it, the more they feel they can improve it and adapt it to the requirements of their crops.

Mr. Burkett's book sets forth in a clear and admirable manner just what the agriculturist wants to know, and should know. It is practical and interesting from cover to cover, and cannot fail but prove of great educational value to all who will carefully read it and act upon the sound advice given.

The author has carefully avoided long technical descriptions, the many excellent and striking diagrams and figures, coupled with the crisp and pithy style the work is written in, make it a book to be strongly recommended to all who wish to learn more of the important subject it treats of.

W. E. C.

Conn, H. W.—Practical Dairy Bacteriology. Pp. xii × 314, 86 text figs. New York: Orange Judd Company. London: Kegan Paul, Trench, Trübner and Co., Ltd., 1907. Price 6s. 6d. net.

The study of Dairy Bacteriology is comparatively speaking a new one, and like many new subjects is apt to be overlooked or receive only scant attention in the curious curricula which exist in our agricultural colleges, we therefore extend a hearty welcome to Dr. Conn's work.

As the author very aptly remarks, the bacteriology of milk products has an intimate relation to two different classes of problems, viz., the problems arising in the dairy proper and affecting purely dairy matters, and the problems of the relation of milk bacteria to the public health.

The work consists of two parts. The first deals in a general manner with the known facts concerning the relation of bacteria in milk, whilst in the second part practical directions for bacteriological analysis and methods of bacteriological study are given.

After a careful perusal of this excellent work, we feel that no student or teacher of agriculture (and particularly of dairying) can afford to neglect it. It is written in a lucid, yet concise style, packed with valuable

[JOURN. ECON. BIOL., 1908, vol. ii, No. 4.]

information, and thoroughly practical throughout. It forms an admirable companion to Dr. Belcher's "Clean Milk," in the same series of standard agricultural works.

W. E. C.

Pearson, R. H.—The Book of Garden Pests. Pp. xiii + 214, 68 figs. London: John Lane, 1908. Price 2s. 6d. net.

The author for fifteen years has been connected with the *Gardeners' Chronicle*, and his experience "has been gained from the specimens received from, and the constant communications made by, correspondents."

Some biological training and practical experience would have better fitted the author for his task, and with the contributions from such men as Curtis, Westwood, and Berkeley, not to mention modern writers, we are surprised that he has not made better use of the materials.

The illustrations are poor, and the remedial measures, in very many cases, crude. This is not a book we can recommend to even the average gardener.

W. E. C.

Saunders, Edward.—Wild Bees, Wasps and Ants, and other Stinging Insects. Pp. xiii + 144, 4 pls. and 28 text figs. London: George Routledge and Sons, Ltd. Price 3s. 6d.

In his Preface the author states that this little work has been written for "lovers of Nature who wish to know a little about the insects they see round them, and how they spend their lives," and very admirably has he performed his pleasurable task.

No one is better qualified than Mr. Saunders to write upon the British Hymenoptera Aculeata, and this work can scarcely fail to excite the interest of all commencing the study.

There is a capital chapter "On Structure," covering just the ground that anyone unfamiliar with this Order of Insects will more than appreciate.

W. E. C.

II.—ANATOMY, PHYSIOLOGY, AND DEVELOPMENT.

van Leeuwen, W., u. Reynvaan, J.—Über die Anatomie und die Entwicklung einiger *Isosoma*—Gallen auf *Triticum repens* und *junceum* und über die biologie der Gallformer. Marcellia, 1907, vol. vi, pp. 68-101, Tav. i, 21 text figs.

III.—GENERAL AND SYSTEMATIC BIOLOGY, AND GEOGRAPHICAL DISTRIBUTION.

Adams, J. A.—Irish Parasitic Fungi. *Irish Nat.*, 1907, vol. xvi, pp. 167-169, 4 figs.

Bezzi, M.—Ulteriori notizie sulla Ditterofauna delle Caverne. *Atti. Soc. Ital. Sci. Nat.*, 1907, vol. xlvi, pp. 177-187.

- Cameron, P.**—Description of a new Species of *Apanteles* from Ceylon. *Spolia Zeylanica*, 1908, vol. v, pp. 17, 18.
The new species is *A. acherontiae*, bred from the larva of *Acherontia lachesis*.
- Caudell, A. N.**—On some Earwigs (*Forficulidae*) collected in Guatemala by Messrs. Schwarz and Barber. *Proc. U.S. Nat. Mus.*, 1907, vol. xxxiii, pp. 169-176.
- Chapman, T. A.**—The Hibernation of *Marasmarcha*. *Trans. Entom. Soc. Lond.*, 1907, pp. 411-414, pl. xxviii.
- Cholodkovsky, N.**—Die Coniferen-Läuse Chermes, Feinde der Nadelhölzer. Pp. 44, Tfn. i-vi. Berlin: R. Friedlander and Sohn, 1907.
- Cockerell, T. D. A.**—The Scale Insects of the Date Palm. *Agr. Exp. Stat., Univ. Arizona, Bull. No. 56*, 1907, pp. 185-192, pls. i-v.
- Fletcher, F.**—Mendelian Heredity in Cotton. *Journ. Agric. Sci.*, 1907, vol. ii, pp. 281, 282.
- Fletcher, T. B.**—Description of a new Plume Moth from Ceylon, with some remarks upon its Life-history. *Spolia Zeylanica*, 1908, vol. v, pp. 20-32, 7 figs.
- Gammie, G. A.**—The Indian Cottons. *Mem. Dept. Agric. India, Bot. Ser.*, 1907, vol. ii, No. 2, pp. 1-23, pls. i-xiv.
- Green, E. E.**—Note on the Parasite *Apanteles acherontiae* of the Caterpillar of the "Death's Head" Moth. *Spolia Zeylanica*, 1908, vol. v, p. 19, 1 fig.
- Guppy, L., Junr.**—Life History of *Cydimon (Urania) leilus*, L. *Trans. Entom. Soc. Lond.*, 1907, pp. 405-410, pls. xxvi, xxvii.
- Hunter, W. D., and Hooker, W. A.**—Information concerning the North American Fever Tick, with notes on other species. *U.S. Dept. Agric., Bur. of Entom., Bull. No. 72*, 1907, pp. 1-87, pls. i-iv, 13 text figs.
A valuable and interesting paper.
- Perrin, W. S.**—Note on the possible transmission of *Sarcocystis* by the Blow-fly. *Spolia Zeylanica*, 1907, vol. v, pp. 58-61, 2 figs.
- Quaintance, A. L.**—The More Important *Aleyrodidae* infesting economic plants, with a description of a new species infesting the Orange. *U.S. Dept. Agric., Bur. of Entom., Tech. Ser.*, No. 12, pt. v, 1907, pp. 89-94, pl. vii, 2 text figs.
Aleyrodes howardi, n.sp.
- Rumsey, W. E.**—Manner of Birth of the Woolly Aphis of the Apple (*Schizoneura lanigera*, Hausm.), and of other *Aphididae*. *U.S. Dept. Agric., Bur. of Entom., Bull. No. 67*, 1907, pp. 31-34.

- Walsingham, Lord.**—Descriptions of new North American Tineid Moths, with a Generic table of the Family *Blastobasidae*. Proc. U.S. Nat. Mus., 1907, vol. xxxiii, pp. 197-228.
- Weber, S. E.**—Mutation in Mosquitoes. Weber's Arch., Lancaster, Pa., 1907, vol. i, no. 2, pp. 1-28, 6 figs.

IV.—AGRICULTURAL AND HORTICULTURAL.

- Amos, A.**—The effect of Fungicides upon the Assimilation of Carbon Dioxide by Green leaves. Journ. Agric. Sci., 1907, vol. ii, pp. 257-266.
- Ball, E. D.**—The Control of the Codling Moth in the Arid Regions. U.S. Dept. of Agric., Bur. of Entom., Bull. No. 67, 1907, pp. 55-57, 4 figs.
- Chittenden, F. H.**—Insects Injurious to Vegetables. Pp. 14 + 262, 163 text figs. New York: Orange Judd Company. London: Kegan Paul, Trench, Trübner and Co., 1907. Price 6s. 6d. net.

No one is better qualified than Dr. Chittenden to write such a work as the one before us, and very admirably has he fulfilled his task.

The work may be divided into three parts, viz., the first, which consists of a general introduction; the second, treating of the value of a knowledge of entomology, the prevention of insect attacks by farming methods, the mechanical methods of destroying insects or preventing injury, and a chapter on insecticides and their uses.

The third part of the work briefly considers the pests injurious to different vegetable crops, and the preventive and remedial measures to be adopted.

The work forms an excellent collation of what has been written in America on vegetable pests, and the concise and practical manner in which the author has put the same, make it a handbook that cannot fail but prove eminently useful to the American farmer and those of other countries also.

W. E. C.

- Collinge, Walter E.**—On the Eradication of the Black-Currant Gall Mite. (*Eriophyes ribis* (Nalepa).) U.S. Dept. Agric., Bur. of Entom., Bull. No. 67, 1907, pp. 119-123.
- Dickerson, E. L.**—Some Observations on the Natural Checks of the Cottony Maple Scale. (*Pulvinaria innumerabilis*, Rathv.). U.S. Dept. Agric., Bur. of Entom., Bull. No. 67, 1907, pp. 48-53.
- Draper, Walter.**—Notes on the Injurious Scale Insects and Mealy Bugs of Egypt; together with other Insect pests and fungi. Pp. 28, 24 figs. Cairo: 1907.

- Forbes, R. H.**—The Extermination of Date Palm Scales. Agr. Exp. Stat., Univ. Arizona, Bull. No. 56, 1907, pp. 193-207, figs. i-v.
- Girault, A. A.**—The Lesser Peach Borer. U.S. Dept. Agric., Bur. of Entom., Bull. No. 68, pt. iv, 1907, pp. 31-48, plt. vi, 1 text fig.
- Hodgkiss, H. E.**—Effects of Sprays on Aphis Eggs. U.S. Dept. Agric., Bur. of Entom., Bull. No. 67, 1907, pp. 29-31.
- Hooker, W. A.**—Observations on Insect Enemies of Tobacco in Florida, in 1905. U.S. Dept. Agric., Bur. of Entom., Bull. No. 67, 1907, pp. 106-112.
- Parrott, P. J.**—The Pear Blister-Mite. (*Eriophyes pyri* (Pgst.), Nal.). U.S. Dept. Agric., Bur. of Entom., Bull. No. 67, 1907, pp. 43-48.
- Salmon, E. S.**—Notes on the Hop Mildew (*Sphaerotheca humuli* (DC.) Burr.). Journ. Agric. Sci., 1907, vol. ii. pp. 327-332, 6 figs.
- Schrenk, H. von.**—Branch cankers of Rhododendron. Rpt. Mo. Bot. Gard., 1907, vol. 18, pp. 77-80, plt. v, and 1 text fig.
- Smith, R. E.**—The Brown Rot of the Lemon. Univ. Calif. Agric. Exp. Stat., Bull. No. 190, 1907, pp. 1-72, 1 plt., 29 figs.
- Smith, R. E.**—Californian Peach Blight. *Ibid.*, Bull. No. 191, 1907, pp. 73-100, 16 figs.
- Smith, E. F., and Townsend, C. O.**—A plant-tumour of bacterial origin. Science, 1907, n.s. vol. xxv, pp. 671-673.
- Taylor, E. P.**—Economic Work against the Howard Scale in Colorado. (*Aspidiotus howardi*, Ckll.). U.S. Dept. Agric., Bur. of Entom., Bull. No. 67, 1907, pp. 87-93.
- Walden, B. H.**—Notes on a new Sawfly attacking the Peach. (*Pamphilus persicum*, Mac G.). U.S. Dept. Agric., Bur. of Entom., Bull. No. 67, 1907, pp. 85-87, plt. i.
- Webster, F. M.**—The value of parasites in Cereal and Forage Crop production. U.S. Dept. Agric., Bur. of Entom., Bull. No. 67, 1907, pp. 94-100, 1 fig.

V.—FORESTRY.

VI.—FISHERIES.

- Colgan, N.**—The Shipworm and Wood-boring Crustaceans in Kingstown Harbour. Irish Nat., 1908, vol. xvii, pp. 9-14.
- Willey, A.**—Report on the Window-pane Oysters (*Placuna placenta*, "Muttuchchippi") in the backwaters of the Eastern Province (June, 1907). Spolia Zeylanica, 1907, vol. v, pp. 33-57, 1 plt. and 5 figs.

Williamson, M. Burton.—The Haliotis or Abalone Industry of the Californian Coast: Preservative Laws. Proc. Am. Hist. Soc., S. Cal., 1907, vol. vii, pp. 22-30.

VII.—MEDICINE.

Hossack, W. C.—An Account of the Rats of Calcutta. Mem. Indian Mus., 1907, vol. i, pp. 1-80, plts. i-viii.

Newstead, R.—Preliminary Report on the Habits, Life-cycle and Breeding places of the Common House-Fly (*Musca domestica*, Linn.), as observed in the City of Liverpool, with suggestions as to the best means of checking its increase. Pp. 23, 14 figs. Liverpool: C. Tinling and Co., Ltd., 1907.

From the standpoint of public health this is a most important report. We are glad to find that city authorities are awakening to the fact that the common house-fly is a serious factor in the spread of disease, and anything that will tend to reduce the numbers must prove of great advantage to the community at large.

VIII.—ANIMAL DISEASES.

Mayo, Nelson S.—The Diseases of Animals. 3rd Ed. Pp. xvi + 459, 59 figs. New York: The Macmillan Company. London: Macmillan and Co., Ltd., 1907. Price 6s. 6d.

Dr. Mayo's work, which has now reached a third edition, gives just the concise, practical directions that can be carried out by those who have to do with the care of animals. Rare and unusual diseases are purposely omitted, as also complicated medicinal treatment, special attention being given to the use of domestic and simple remedies.

As one might expect from a practitioner and teacher of many years standing, the work is eminently practical, and should find a place on the shelf of all interested in live stock.

W. E. C.

Smith, F.—A Manual of Veterinary Physiology. 3rd Ed. Pp. xvi + 715. London: Baillière, Tindall and Cox, 1907. Price 15s. net.

IX.—COMMERCIAL.

Browne, C. A.—Methods of Honey Testing for Bee Keepers. U.S. Dept. Agric., Bur. of Entom., Bull. No. 75, pt. i, 1907, pp. 16-18.

Howard, C. W.—Notes on Termites. Trans. Agr. Journ., 1907, vol. vi, pp. 85-92.

A report on some experiments for rendering wood for building purposes, immune to the attacks of these insects.

Phillips, E. F.—Production and Care of Extracted Honey. U.S. Dept. Agric., Bur. of Entom., Bull. No. 75, pt. i, 1907, pp. 1-15.

	PAGE		PAGE
I.			
<i>Idia lunata</i> , Meig., parasitic on		<i>Phorbia brassicae</i> . Life-history of ..	61
<i>Schistocerca peregrina</i> , ..	83, 87	Plant and Animal Breeding. ..	100
Insect enemies of Insects. 19, 80, 81, 82, 83,	87, 103	<i>Pulvinaria jacksoni</i> , n. sp. (figs.) ..	155
<i>Ixodidae</i> . Determination of Genera of	91	S.	
<i>Ixodidae</i> . Diagnosis of species of ..	92	Spruce-gall disease.	1
<i>Ixodidae</i> . Genera of	90	<i>Stictococcus</i>	150
<i>Ixodidae</i> . List of principal species of	94	<i>Stictococcus multispinosus</i> , n. sp. ..	150
<i>Ixodidae</i> . New classification of ..	90	<i>Stictococcus sjöstedti</i> , Ckll.	149
L.			
Larch-blight disease.	1	Stone, Herbert.—“Hints on the Col- lecting of Timber Specimens.” ..	26
Leaf-hoppers. Damage by	23	T.	
Leaf-hoppers. Natural enemies of ..	19	<i>Tachinidae</i> parasitic on Lepidoptera. 80, 81,	82
Leaf-hoppers. Oak and fruit.	16	<i>Thelymorpha vertiginosa</i> , Fl., parasitic on the Brown Tail Moth.	82
Leaf-hoppers. Prevention and treat- ment.	22	Theobald, Fred V.—“New Hemip- terous Fruit Pests in Britain.” ..	14
Locusts. Insects destroying their eggs.	87	<i>Thrixion halidaynum</i> , Rond., parasitic on a Phasmid.	81
<i>Lophyrus pini</i> . Life-history of ..	50	Ticks. Notes on	89
<i>Lophyrus pini</i> . Parthenogenesis in ..	49	Timber. Hints on the collecting of specimens	26
M.			
MacDougall, R. Stewart.—“Partheno- genesis in <i>Lophyrus pini</i> .”	49	Timber. Packing and forwarding specimens of	30
<i>Musca domestica</i> , L. Breeding places of	84	Trees. Brandis' Indian (Review.)	32
<i>Muscidae</i> destroying locusts.	83, 87	<i>Typhlocyba quercus</i> , Fabr.	16
N.			
Newstead, Robert.—“On the Structu- ral Characters of Three Species of <i>Coccidae</i> affecting Cocoa. Rub- ber, and other plants in Western Africa.”	149	U.	
P.			
<i>Palaeococcus theobromae</i> , n. sp. (figs.)	154	<i>Ugimya sericaria</i> attacking <i>Bombyx</i> <i>mori</i>	80
Parthenogenesis in <i>Lophyrus pini</i> . ..	49	W.	
		Warburton, Cecil.—“Notes on Ticks.”	87
		Y.	
		Yellow leaf-hoppers.	17

Fig. 4.

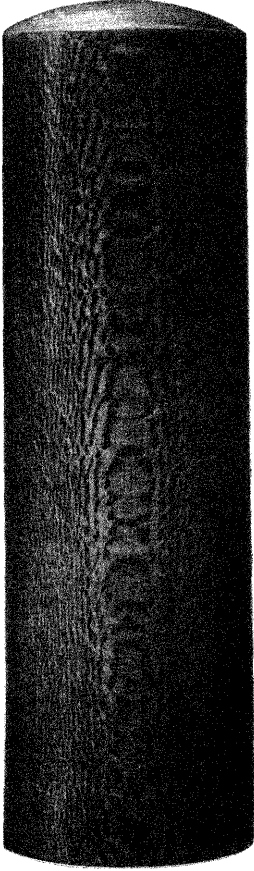

Fig. 5.

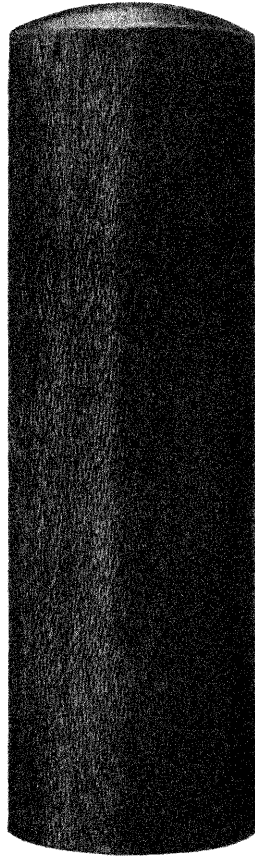

Fig. 6.

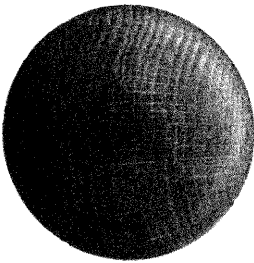
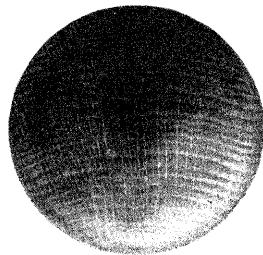

Fig. 7.



SECTIONS, ETC., OF WOOD OF MYRSINE.

forwarded loose. Other specimens will, of course, be in cases. Sawdust should not be used for packing, as it becomes damp, and harbours insects, etc. Shavings are better, but the best plan is to have the case made to fit the goods, and then to wedge them tight, with quoins or similar devices.

EXPLANATION OF PLATES III & IV.

Illustrating Mr. Herbert Stone's paper on "The Collecting of Timber Specimens."

Fig. 1.—Transverse section of the wood of *Stenocarpus salignus*. Scale $\frac{1}{4}$.

(a) Bark; (b) Sapwood; (c) Heartwood; (d) Centre; (a-e) Surface parallel to a Ray; (e-f) Surface at right angles to the Rays. The annual rings are faintly shown as concentric arcs.

Fig. 2.—The same seen from a different point. Scale $\frac{1}{4}$.

(a) Transverse section; (b) Radial section showing fragments of the Rays (Silver-grain); (c) Tangential section showing the Rays in section as spindle-shaped bodies.

Fig. 3.—As (c) in Fig. 2. Scale $\frac{1}{4}$.

(a) Bark; (b) Sapwood; (c) Heartwood.

Fig. 4.—A cylinder of the wood of *Myrsine merlanophleas*, placed so as to show the Silver-grain in front. Scale $\frac{1}{8}$ rd.

Fig. 5.—The same showing the tangential section in front.

Figs. 6 and 7.—End view of the cylinder, showing the direction of the Rays and annual rings in Figs. 4 and 5. The Rays are shown running horizontally in Fig. 6 and vertically in Fig. 7, and the Rings *vice versa*.

BRANDIS' INDIAN TREES.¹

THE publication of this splendid work on Indian trees, shrubs, canes, bamboos and palms forms a fitting close to the great services that Sir Dietrich Brandis has rendered to the Indian Empire. Dealing, as it does, with 4,400 species, it is one of the largest Forest Floras in existence. Sargent's "Manual of the Trees of North America" describes about 700 species, while Matthieu's "Flore forestière de la France" deals with 397 species only. To this work Brandis has devoted the last eight years of his long laborious life, being now in his eighty-fourth year; the collection of materials for the book commenced, however, in 1856, when he was appointed by the Government of India to the charge of the Pegu Forests.

After saving the valuable Burmese teak forests from being leased to and ruined by timber merchants, he was placed, in 1862, on special duty to organize Forest Administration in the other provinces of India, and became Inspector General of Forests to the Government of India in 1864, a post he held for eighteen years. After procuring the services of Schlich and Rebbentrop, German forest officers, in 1866, in 1869 he introduced officers trained in European Forests to the Indian Forest Department; in 1878 he founded the Dehra Dun Forest School for native Indian executive and controlling forest officers, and he retired in 1882, after having inspected every forest of importance in British India and written the clearest descriptions of them in his reports to Government. He also introduced forest law to India, and has practically built up a new branch of the public service. Some results of his energy may be gathered from the fact that in 1904, the last year for which I have figures, there were 101,442 square miles of managed Indian State forests, yielding a net revenue of £560,000, while a vast amount of forest produce was given away to the people.

Brandis' earlier work on the Forest Flora of North-west and Central India, which was published in 1874, was considered by Sir

¹ Indian Trees, an account of Trees, Shrubs, Woody Climbers, Bamboos and Palms, indigenous or commonly cultivated in the British Indian Empire. By Dietrich Brandis, K.C.I.E., F.R.S., etc., assisted by Indian Foresters. Pp. xxxiv + 767, and 201 text figs. London: Archibald Constable & Co., 1906. Price 16s. net.

Joseph Hooker as a classical Forest Flora, and a model of what such works should be. That book is now out of print, and is replaced by the one under review, the scope of which has been enlarged so as to cover all British India. The author hopes that small profitable local forest floras for different parts of India may be compiled from it. One excellent work of that class, "The Forest Flora of the Dehra Dun School Circle," and practically for the United Provinces of Agra and Oudh, by Rai Sahib Kangilal, has been already published, with a key to the natural orders and to genera and species, so that it is extremely useful to foresters. The present work gives keys to genera only, the object being not to overload the book, already sufficiently bulky.

When, in 1898, Brandis commenced writing "Indian Trees," Mr. J. S. Gamble, C.I.E., F.R.S., proposed that it should be confined to the commoner and more useful species of Indian woody plants, but this limitation was rejected by the author on the following grounds. "I pictured to myself," says he, "one of my young colleagues in Burmah, who had come across a large tree, which from the wings on the fruit he recognized as a Dipterocarp. If this book contained only a description of the more important species of Dipterocarps, such as *Dipterocarpus, alatus*, *D. tuberculatus*, *Hopea oderata*, and *Shorea robusta*, it would not help him, as there are more than twenty similar species in Burma." Brandis' ambition has been to publish a pathfinder through the bewildering varieties of trees, shrubs, climbers, bamboos and palms, which constitute the forests in the different provinces of India. He does not maintain that foresters should know all these, but that they should have the means of becoming acquainted with them without loss of time. Quite unexpectedly, a shrub, climber, bamboo, or tree may be found to be of considerable importance from a forester's point of view, and he should then have easy means of identifying the species in question.

As regards the limitation of species, the author is, and always has been, of the opinion that as long as *the matter has not been determined in the field*, it is better to leave well-established species alone, and not to split them up. Thus he does not agree with Colonel Prain in separating *Acacia mollis* from *A. julibrissin*, which he regards as a widespread species, extending from Abyssinia to Japan. Wherever decided specific differences exist, Brandis is always ready to admit them. Thus, as regards *Quercus pedunculata*, and *Q. sessiliflora*, united as *Q. robur*, by Sir J. Hooker, and by Professor Marshall Ward, Brandis asserts that by their botanical characters and mode of growth, and especially by their requirements as regards soil, drainage, and their companionship of other trees, they are distinct species, requiring different treatment by foresters. Their being united as one species in Britain, though not

on the Continent, is due to the predominance of pedunculate oak in our clayey lowlands, and the comparative ease with which its acorns are harvested and sown by nurserymen. The latter sell pedunculate oak plants to land-owners in our western and northern hilly districts, where the trees have interbred with the indigenous sessile oak, the latter being rarely planted, so that, except in Wales, pure crops of sessile oak are rare, while hybrids between the two species abound. Sir Herbert Maxwell says that there are now rows of indigenous sessile oaks along the banks of rivers in the S.W. of Scotland, the remains of ancient forests. Mere herbarium specimens do not suffice to determine species, plants should be seen *in situ* at different stations by experienced botanists, before it can be decided whether different species or varieties are in question.

"Indian Trees" forms a handsome volume with 767 pages, separate indices of Indian vernacular, European and scientific names. The type is very clear, and the paper good. The illustrations by Dr. Ronald Anheisser, of Cologne, are excellent, but illustrate only the less known species. As it is, they alone cover 60 pages, so that with more illustrations the book would have become unwieldy.

Sir D. Brandis was a professor of botany at Bonn, when he joined the Indian Forest Service, and during his stay in India made a large herbarium. On his retirement, in 1882, he devoted a long time to the study of all recent botanical literature, and worked hard with the microscope, so as to render himself acquainted with recent botanical research. He contributed a monograph on Dipterocarpaceae to Engler and Prantl's "Naturliche Pflanzenfamilien." He has constantly resided at Kew for the last eight years, and has freely used the splendid herbarium there, as well as Wallich's herbarium at the Linnean Society, and the collection in the Natural History Museum at South Kensington. He has therefore spared no pains to render his book complete, and has been assisted by many Indian foresters whose names he mentions in his Introduction. In the latter also he gives some useful notes regarding the geographical distribution of trees, but a concise work on the Geographical Botany of India has yet to be written. Gamble's Indian Timbers, published in 1902, gives a description of the wood of 1,450 species, and is a useful companion to the present work for economic botanists.

W. R. FISHER.

Oxford,
Dec. 20th, 1906.

REVIEWS AND CURRENT LITERATURE.

I.—GENERAL SUBJECT.

Folsom, J. W.—Entomology, with special reference to its Biological and Economic Aspects. Pp. vii + 435, with 5 pls. and 300 text figs. London: Rebman, Ltd., 1906. Price 14/- net.

Dr. Folsom's work is essentially a biological treatment of entomology. A short chapter on classification, in which the author sets forth his views on the phylogeny and relationship of the different Orders of Insects, is perhaps the least satisfactory one in the work.

Those chapters devoted to the anatomy, physiology, and development, adaptations of aquatic insects, colour and colouration, the origin of adaptations and of species, the relationship of insects to other animals and to plants, their interrelations, behaviour, distribution and economic importance, are all characterised by a freshness which must at once commend the work to all.

After a careful perusal of the various chapters we are struck by the few omissions, the most striking one perhaps being any reference to the Mendelian school of workers.

The illustrations throughout are considerably above the average and a large proportion are original. The admirable bibliography completes a work which we feel sure will find many appreciative English readers.

W. E. C.

Knuth, P.—Handbook of Flower Pollination. Translated by J. R. Ainsworth Davis. Vol. i, pp. xix + 382, and 81 text figs. Oxford: The Clarendon Press, 1906. Price 18/- net.

A fascinating work, of which we are pleased to see an English translation. The present volume gives a summary of the historical development of flower pollination, an exhaustive account of the present standpoint of flower pollination, and excellent bibliography. There will be two further volumes to complete the work.

Massee, G.—Text Book of Fungi. Pp. xi + 427, and 141 text figs. London: Duckworth and Co., 1906. Price 6/- net.

It is difficult to know how to characterise the impression which the first part of this book makes upon the reader, without using language which might appear unduly harsh. If one should wish to crystallise the idea which it conveys into a single word, perhaps the appropriately awkward term "formlessness" is the least inadequate. The writer has

evidently been engaged in recent years in the laudable occupation of keeping a commonplace book on the Physiology of Fungi, and, the book being full, he has thought the present moment opportune for emptying its contents before the public.

Such a course may sometimes result in a work of great usefulness or interest, provided the author has the skill to utilise fully his materials. But the mere unloading of the accumulated snippets is not all that is required. Here one looks in vain for any of that labour in revision which would weld the fragments of knowledge into an organic whole, such as one would have expected and obtained from a Berkeley or a Cooke. There is nothing but a maze of words, without plan or cohesion, without aim or result. One feels tempted to exclaim, in parody of the late poet-laureate:—"Better fifty lines of Berkeley than this mass of Masee's prose."

The frequent repetitions of the same facts (often with confusing differences of detail) in different pages of the book, the want of subordination and co-ordination among the headings of the sections, the absence of any attempt to proportion the space allotted to a section to the importance of its subject, the frequent instances of careless grammar—all bear out the idea which suggests itself at first reading, that the work must be regarded merely as a glorified note-book.

The absence of revision betrays itself in one particular especially, the omission to use the same term in the same sense throughout the book. When a number of independent workers are engaged upon different groups of fungi in different parts of the civilised world, it is inevitable that there should arise among them a want of uniformity in the use of certain terms. Such a discrepancy it is the province of the writer of a text-book to remove, but the present volume makes no attempt in this direction. We defy anyone, however skilled, to emerge from the paragraphs devoted to the "spore" without feeling that confusion is worse confounded; yet in this particular alone a most useful piece of work is waiting to be done. Nor is this the only instance of want of clearness. There are many sentences whose meaning no one could disinter. When one reads the works of a great author, one does not object to the labour of extracting his meaning from his pregnant sentences; but such cryptic utterances are not permitted to the lesser lights, the mere journeymen workers of science. For them no stamping-mills, no cyanide vats wait in order to separate the refined gold from the dross of ore. From them we exact hyalinity of expression, under penalty of speedy oblivion.

A few examples of the inaccuracies referred to must be given. On p. 19 we read that "the cell-sap . . . explains that substances in solution in water act like gases." The mode of infection of cereals by "smut" spores is described (pp. 214, 221) in two semi-contradictory ways, the onus of reconciling which falls upon the reader. The same identical set of experiments with diseased potato tubers is described twice over (pp.

217, 223) in totally different words, without a hint to that effect. On p. 85 "archegonia" are attributed to *Sphaerotheca* and *Erysiphe*; on p. 193 we read that, in the absence of the sexual phase, "*Plasmopara infestans*" (whatever that may be—the correct name is given to it on p. 202) belongs technically to the Hyphomycetes." How long, we may ask, has the possession of zoospores been the technical mark of that order?

The middle paragraph on p. 11 is a typical instance of Mr. Masee's habit of jumbling together totally unrelated topics, to the worry and annoyance of the unwary reader. *Lentinus tigrinus* is given on p. 120, when *L. lepideus* is meant; the respiratory ratio appears twice as C O 2/O, instead of C O 2/O 2. A student of Fungi, in these days, is not expected to know that the *Agaricus velutipes* of p. 120 is the same as the *Collybia velutipes* of p. 48, or the *Ithyphallus impudicus* of p. 23 as the *Phallus impudicus* of p. 114. Most amazing of all, *Agaricus melleus* is referred to on p. 106, while facing it appears, on p. 107, an illustration of a species called *Armillaria mellea*.

The smudgy or washed-out illustrations are another blemish to the book. Not one of them could pose as a "proof before letters" Most of them have done duty before, and as they are here sandwiched amidst the text, the majority of them occurring more than once, often with the flimsiest excuse, they can hardly be said to illustrate anything except the decadence of popular taste, and the ineptitude of those responsible for their choice.

In conclusion, a more pleasant task awaits us, as we can congratulate Mr. Masee upon three things. Firstly, in the part which treats of Systematic Classification, where doubtless he feels more at home, the blemishes to which we have referred are less conspicuous; but why did he begin this important chapter at the bottom of a page? Secondly, at the end of every section he has given a full bibliography of the subject, so that the student can clear his befogged brain by referring to the original sources; and, thirdly, there is a total absence from this work of Mr. Masee's customary undignified and petulant sneers at other workers of the past, who possessed few of those advantages in which the student of Fungi can revel at the present day.

W. B. GROVE.

II.—ANATOMY, PHYSIOLOGY, AND DEVELOPMENT.

- Berlese, Antonio.**—Sopra una anomalia negli organi sessuali esterni femminei di *Locusta vividissima*, L. Redia, 1906, vol. iii, pp. 305-314, 7 text figs.
- Bugnion, E.**—Les oeufs pédiculés du *Cynips tozae* et du *Synergus reinhardi*. Bull. Soc. Vaudoise Sci. Nat., 1906, vol. xlii, pp. 185-196.
- Harper, R. A.**—Sexual Reproduction and the Organization of the Nucleus in Certain Mildews. Publication No. 37, pp. 1-104, pls. i-vii. Washington: Carnegie Institution, 1905.

If for no other reason, workers in all parts of the world must feel indebted to the Carnegie Institution for the splendid manner in which it publishes the results of various investigations. Mr. Harper's memoir is a case in point, and a valuable contribution to the subject of which it treats.

Houard, C.—Anatomie de la "galle en capsule" de *Euphorbia cyparissias*. Rev. Gen. de Bot., Paris, 1906, pp. 241-251, 19 text figs.

Imms, A. D.—Anurida. Liverpool Mar. Biol. Comm. Memoirs, xiii. Pp. 1-100, pls. i-vii. London: Williams and Norgate, 1906. Price 4/-.

The little marine collembolan or springtail *Anurida maritima* is among the best known of our shore-haunting insects, and many zoologists have been attracted to its study. Mr. Imms has brought together in this convenient memoir a full summary of the work of previous observers, and adding many valuable observations of his own, has produced a clear and comprehensive booklet. He deals first with the binomics and distribution of *Anurida*, and then devotes the largest section of the volume to its structure internal and external; this is followed by a short but good account of the embryology mainly compiled from the writings of Claypole and Folsom. The wide problems suggested by the study of *Anurida* are not forgotten, for the author discusses in conclusion, the general structure and affinities of the Collembola, and gives a short survey of our knowledge of marine insects generally. The seven plates of excellent figures, most of them original, are creditable alike to the author and lithographers. Economic biologists will find that Mr. Imms has not neglected the damage done by certain springtails to cultivated plants, not forgotten to call attention to the fact that their presence in water pipes or hydrants is a sign of the contamination of the supply.

G. H. C.

Marchal, P.—Recherches sur la biologie et la développement des Hyménoptères parasites. II. Les Platygasters. Arch. Zool. exp. et gén., 1906, iv ser., T. iv, pp. 485-640, pls. xvii-xxiv, and 11 text figs.

This is a valuable and beautifully illustrated piece of work on the development and the relations to the host of certain species of *Proctotrupidae*. All the six species treated of live on the larvae of *Cecidomyae*. After a very full review of the literature and previous work, the author gives a detailed account of the development of the different species, the reactions set up in the tissues of the hosts, and the gall-like cysts the parasites produce in their tissues.

Stevens, N. M.—Studies on the Germ Cells of Aphids. Publication No. 51, pp. 1-28, pls. i-iv. Washington: Carnegie Institution, 1906.

Much of the value of this paper is destroyed by the fact that the

author does not give the scientific names of the different species of Aphids of which he is treating.

He finds that the number, form, and size of the chromosomes is characteristic of different species. No evidence of hybridism was observed where two or more species occur on the same host.

III.—GENERAL AND SYSTEMATIC BIOLOGY, AND GEOGRAPHICAL DISTRIBUTION.

Austen, E. E.—Illustration of British Blood-Sucking Flies. Pp. 1-74, 34 cold. pls. and 1 text fig. British Museum (N.H.). Printed by Order of the Trustees. London: 1906. Price 25/-.

All interested in the study of the Diptera of the British Isles will welcome this beautifully illustrated work. Although the blood-sucking flies of this country are no longer the serious pest they once were, those of other countries are a very serious factor in the dissemination of diseases affecting man and other animals, and the work before us may serve as an introduction to those about to devote themselves to those diseases.

The notes supplied about each species seem somewhat incomplete, but as the author remarks, no attempt has been made to supply detailed technical descriptions, and owing to the limitations of space a considerable amount of matter relating to the life-history of the species has been omitted.

The primary object of the work is to facilitate, by means of the plates, the identification of the different species of British blood-sucking flies, and this has been fully accomplished.

W. E. C.

Banks, Nathan.—A Revision of the *Tryoglyphidae* of the United States. U.S. Dept. Agric., Bur. of Entom., Tech. ser. No. 13, 1906, pp. 1-34, pls. i-vi.

Berlese, Antonio.—Probabile metodo di lotta efficace contro la *Ceratitis capitata*, Wied., e *Rhagoletis cerasi*, L., ed altre Tripetidi. Redia, 1905, vol. iii, pp. 386-388.

Berlese, A., e Paoli, G.—Serie maschile della *Pollinia pollinii*, Costa. Ibid., pp. 393-395, 3 text figs.

Berlese, A., Silvestri, F.—Descrizione di un nuovo genere e di una nuova specie di Lecanite vivente sull'olivo. Ibid., pp. 396-407, 18 text figs.

Cecconi, G.—Contribuzione alla Cecidologia toscana. Marcellia, 1906, vol. v, pp. 39-43.

Chittenden, F. H.—Harvest Mites, or "Chiggers." U.S. Dept. Agric., Bur. of Entom., Circ. No. 77, 1906, pp. 1-6, 3 text figs.

Cooke, W. W.—Distribution and Migration of North American Ducks, Geese, and Swans. U.S. Dept. Agric., Biol. Sur., Bull. No. 26, 1906, pp. 1-90.

Galli-Valerio, B. et Jeanne Rochaz-de-Jongh.—Manuel pour la Lutte contre les Moustiques. Pp. 245, avec 94 gravures. Lausanne and Paris: A. Maloine, 1906.

This little work may be described as a résumé of our present knowledge of mosquitoes, and all connected either directly or indirectly with them. It is divided into six sections, the first four of which deal respectively with the Morphology, Biology, Classification, and the relation to disease of these Insects. There then follows a chapter on the technique necessary for the study of mosquitoes and the blood-parasites which are transmitted through their agency. The final section of the book deals with the methods in use for combating these Insects in the various stages of their life-history.

An excellent feature is the numerous references to the extensive literature on the subject, which are distributed in the form of foot-notes throughout the work. Considering the small size of the book (it will easily go in the pocket) the majority of figures are sufficient for the purpose they are intended. Some of them, however, which are reproduced from photographs, can hardly be said to be a success.

The work appears to be thoroughly up-to-date, and can be recommended to all who have neither time nor opportunity to consult the various memoirs on the different aspects of the subject.

A. D. IMMS.

De Stefani Perez, T.—Miscellanea cecidologica. Marcellia, 1906, vol. v, pp. 127-130.

De Stefani Perez, T.—Contributo all'Entomofauna dei Cecidii. Ibid., pp. 131-134.

Del Guercio Giacomo.—Intorno a tre specie di mizozilini italiani e alla diverse galle prodotte da vari afidi nel *Populus nigra*. Redia, 1906, vol. iii, pp. 360-385, 31 text figs.

Doncaster, L.—On the Colour-Variation of the Beetle *Gonioctena viriabilis*. Proc. Zool. Soc., 1905 [1906], pp. 528-536.

Doncaster, L., and Raynor, G. H.—On Breeding Experiments with Lepidoptera. Ibid., 1906, pp. 125-133, pl. viii.

Fernald, H. T.—The Digger Wasps of North America and the West Indies belonging to the Sub-family *Chlorioninae*. Proc. U.S. Nat. Mus. 1906, vol. xxxi, pp. 291-423, pls. vi-x.

Gussow, H. T.—*Eriophyes*—(*Phytoptus*)—Knospengallen und Herenbesen der Birte. Zeit. Land-u Forst., 1906, pp. 1-9, Tfn. xxiv-xxv, 9 text figs.

Haseloff, E., and Mach, F.—Ueber die Zerstörung der Futtmittel durch Schimmelpilze. Mitt. Landw. Versuch. Marburg Landw. Jahrb., 1906, pp. 445-465.

- Hine, James S.**—Habits and Life Histories of some Flies of the Family *Tabanidae*. U.S. Dept. Agric., Bur. of Entom., Tech. Ser. No. 12, pt. ii, 1906, pp. 19-38, 12 text figs.
- Houard, C.**—Les Galles de l'Afrique occidentale française. *Marcellia*, 1906, vol. v, pp. 3-22, figs. 1-21.
- Houard, C.**—Sur une Coléoptéroécidie du Maroc. *Ibid.*, pp. 32-38, 8 text figs.
- Houard, C.**—Cécidies produites par le *Perrisia capsulae*, Kieff., sur l'*Euphorbia cyparissias* L. *Ibid.*, pp. 61-65.
- Houard, C.**—Modifications histologiques produites par des *Copium* dans les fleurs des *Teucrium*. *Ibid.*, pp. 83-101, 27 text figs.
- Houard, C.**—Glanures cécidologiques. *Ibid.*, pp. 65-69, 5 text figs.
- Howard, L. O.**—On the parasites of *Diaspis pentagona*. *Redia*, 1906, vol. iii, pp. 389-392, 1 text fig.
- Kieffer, J. J., und Nielsen, J. C.**—Eine neue Weidengallmücke. *Entom. Meddelelser*, 1906, pp. 1-4.
- Kieffer, J. J.**—Deux nouveaux représentants du genre *Rhabdophaga*. *Marcellia*, 1906, vol. v, pp. 70-74.
- Kieffer, J. J.**—Description d'un genre nouveau et de neuf espèces nouvelles de Cynipides exotiques. *Ibid.*, pp. 101-110.
- Kieffer, J. J., e Cecconi, G.**—Un nuovo Dittero galligeno su foglie di *Mangifera indica*. *Ibid.*, pp. 135-136, 3 text figs.
- Küster, E.**—Ueber zwei organoide Gallen: Die Wiederholung blattrantartiger Strukturen auf Blattspreiten. *Ibid.*, pp. 44-48.
- Lowe, E. E.**—Aquatic-dwelling Weevils. *Nature*, Sept. 27th, 1906, p. 541.
- McAlpine, D.**—The Rusts of Australia: their Structure, Nature, and Classification. Dept. Agric., Victoria, Melbourne, 1906, pp. vii + 349, 55 plts. and 28 text figs.
- This work is divided into two parts, the first treating of the general characters and the mode of life of the *Uredineae*, or rusts, and the second of the classification and technical descriptions of the Australian species.
- The work has been well done, and must commend itself to mycologists. It is excellently illustrated, many of the plates being coloured, and well indexed.
- McCracken, Isabel.**—Inheritance of Dichromatism in *Lina* and *Gastroidea*. *Journal Exp. Zool.*, 1906, vol. iii, pp. 321-336.
- Marchal, P.**—Contribution a l'étude des *Chermes*. *Bull. Soc. Entom. France*, 1906, pp. 179-182.
- Massalongo, C.**—Nuovi Zoocécidii della Flora veronese. *Marcellia*, 1906, vol. v, pp. 26-32, 1 text fig.

- Nalepa, A.**—Ueber das Praeparieren und Konservieren der Gallmilben. *Ibid.*, pp. 49-61.
- Nalepa, A.**—*Cecidobia*, Nathan Banks, ein Angeblich neues Eriophyiden Genus. *Ibid.*, pp. 124-126.
- Neumann, L. G.**—Notes sur les Mallophages. *Bull. Soc. Zool. France*, 1906, T. xx, pp. 54-60.
- Oberholser, H. C.**—The North American Eagles and their Economic Relations. U.S. Dept. Agric., Biol. Surv., *Bull. No. 27*, pp. 1-31, pls. i, ii, 2 text figs.
- Rainbow, W. J.**—A Synopsis of Australian Acarina. *Rec. Austr. Mus.*, 1906, vol. vi, pp. 145-193, figs. 33-37.
- Reijnvaan, Jenny, and W. van Leeuwen.**—Variegated Galls of *Cynips kollari*, Hartig. *Marcellia*, 1906, vol. v, pp. 81-82, 1 text fig.
- Rudneff, D.**—Ueber die Rhopalomyiagallen von *Pyrethrum bipinnatum*. *Ibid.*, pp. 23-26, 1 text fig.
- Shiraki, T.**—Die Blattiden Japans. *Annot. Zool. Jap.*, 1906, vol. vi, pp. 17-35, T. ii.
- Silvestri, Filippo.**—Descrizione di un nuovo genere di *Rhipiphoridae*. *Redia*, 1906, vol. iii, pp. 315-324, Tav. xx.
- Silvestri, Filippo.**—Note sui Machilidæ. III-IV. *Ibid.*, pp. 325-340, 15 text figs.
- Silvestri Filippo.**—Contribuzione alla conoscenza dei Termitie di Termitofili dell'Eritrea. *Ibid.*, pp. 341-359, 22 text figs.
- Trotter, A.**—Nuovi Zoocecidii della Flora italiana. *Marcellia*, 1906, vol. v, pp. 111-123.
- Trotter, A.**—Miscellanee Cecidologiche. *Ibid.*, pp. 75-80.
- Toyama, K.**—On the Polygamous Habit of the Silk-worm. *Bull. Coll. Agric*, Tokyo, 1906, vol. vii, pp. 125-145.
- Toyama, K.**—Contributions to the Study of Silk-worms. On the parasitic fly of the domesticated silk-worms of Siam. *Ibid.*, pp. 247-257, plt. v.
- Toyama, K.**—On some Silk-worm Crosses, with special reference to Mendel's Law of Heredity. *Ibid.*, pp. 257-393, 6 pls.
- Woodworth, C. W.**—The Wing Veins of Insects. *Univ. of Calif. Pub., Tech. Bull., Entomology*, 1906, vol. i, no. i, pp. 1-152, 101 text figs.

IV.—AGRICULTURAL AND HORTICULTURAL.

- Bedford, The Duke of, and Pickering, S. U.**—Sixth Report of the Woburn Experimental Fruit Farm. Pp. v + 235. London: Eyre & Spottiswoode, 1906. Price 4s.

This is a valuable report, but not at all well put together, indeed it would well repay re-editing, and shorn of much of its prolixity its present length might easily be reduced.

The authors detail, often to tediousness, a large number of experiments made with various insecticides. Many of the results are really valuable, and had they been presented in a somewhat different style, and full references given to the work of others, this 6th report would have been a really important contribution to the subject of insecticides.

We fully agree with the good parts, and much of the old news in a new setting, which has long been known to economic entomologists in this and other countries.

The authors severely criticise many of the Board of Agriculture's leaflets. An index would have proved a great boon.

L. G.

Bloomfield, J. E.—Structure and Origin of Canker [?] of the Apple Tree. Quart. Journ. Micros. Sci., 1906, vol. 49, pp. 573-579, plt. 32.

A somewhat unfortunate title. The author describes the gall-like swellings caused by *Schizoneura lanigera*, and not "canker" as generally understood, which is of course due to the fungus *Nectria ditissima*.

Butler, E. J.—Some Diseases of Palms. Agric. Journ. of India, 1906, vol. i, pp. 299-310, pls. xx, xxi.

Burkill, I. H.—*Gossypium obtusifolium*, Roxburgh. Mem. Dept. Agric. India, Botan. Ser., 1906, vol. i, no. 4, pp. 1-10, 1 plt.

Chittenden, F. H.—The Melon Aphis. (*Aphis gossypii*, Glov.) Ibid., Circ. No. 80, 1906, pp. 1-16, 6 text figs.

Cooke, M. C.—Fungoid Pests of Cultivated Plants. Pp. xv + 278, 24 cold. pls. and 23 text figs. London: Spottiswoode & Co., Ltd., 1906. Price 10s. 6d.

Dr. Cooke's interesting work is apt at first sight to be misjudged, it is therefore necessary to remind the reader that his "object has been to interest and instruct the cultivator in the simplest and most practical manner." This object, in our opinion, he has more than fulfilled. Horticulturists and Gardeners generally will find the work a very handy one for reference.

There is a short Introduction, then follows a description of the various species of fungi, grouped according to the nature of their hosts, numerous references, and a good index. The work is well illustrated and published at a reasonable price.

W. E. C.

Felt, E. P.—The Gipsy and Brown Tail Moths. N.Y. State Mus., Bull. No. 103, 1906, pp. 1-42, pls. 1-10.

Felt, E. P.—21st Report of the State Entomologist on Injurious and other Insects of the State of New York, 1905. N.Y. State Mus., Bull. 104, 1906, pp. 49-186, pls. 1-10, text figs. 1-48.

Dr. Felt's Reports are always full of interest and valuable information, and the present one is no exception to the rule. Among the more important

contributions we would mention an account of the Grass Webworms (*Crambus*), and Studies in *Cecidomyiidae*, the latter a most valuable contribution.

W. E. C.

- Hinds, W. E.**—Proliferation as a factor in the natural control of the Mexican Cotton Boll Weevil. U.S. Dept. Agric., Bur. of Entom., Bull. No. 59, 1906, pp. 1-45, pls. i-vi.
- Howard, L. O.**—The Gypsy and Brown-tail Moths and their European Parasites. Yearbook U.S. Dept. Agric., 1905. Washington, 1906, pp. 123-138, pls. i, ii, and 8 text figs.
- Howard, L. O.**—The Brown-tail Moth and how to control it. U.S. Dept. Agric., Farmers' Bull. No. 264, 1906, pp. 1-22, 10 text figs.
- Howard, L. O., and Burgess, A. F.**—The Laws in Force against Injurious Insects and Foul Brood in the United States. U.S. Dept. Agric., Bur. of Entom., Bull. No. 61, 1906, pp. 1-222.
- Howell, A. H.**—Birds that eat the Cotton Boll Weevil. U.S. Dept. Agric., Biol. Sur., Bull. No. 25, 1906, pp. 1-22.
- Johnson, S. A.**—The Cottony Maple Scale (*Pulvinaria innumerabilis*, Rathvon). Bull. 116, Agric. Exp. Stat. Colorado, 1906, pp. 1-16, 4 figs.
- Johnson, F., and Girault, A. A.**—The Plum Curculio (*Conotrachelus nemophar*, Herbst.). U.S. Dept. Agric., Bur. Entom., Circ. No. 73, pp. 1-10, 5 text figs.
- Lantz, D. E.**—Meadow Mice in relation to Agriculture and Horticulture. Yearbook U.S. Dept. Agric., 1905. Washington, 1906, pp. 363-376, pls. xxxviii-xli, 1 text fig.
- Lefroy, H. M.**—The Caterpillar Pest of Indigo in Behar. Agric. Journ. of India, 1906, vol. i, pp. 338-350, plt. xxiii.
- Marlatt, C. L.**—The San Jose or Chinese Scale. U.S. Dept. Agric., Bur. of Entom., Bull. No. 62, 1906, pp. 1-89, pls. i-ix, and 12 text figs.
- Orton, W. A.**—Plant Diseases in 1905. U.S. Dept. Agric., 1905. Washington, 1906, pp. 602-611.
- Phillips, E. F.**—The Brood Diseases of Bees. U.S. Dept. Agric., Bur. of Entom., Circ. No. 79, 1906, pp. 1-5.
- Phillips, J. L.**—Lime-sulphur wash Studies, 1904-1906. Virginia State Crop Pest Comms., 1906, Circ. No. 1, pp. 1-23.
- Quaintance, A. L.**—The Principal Insect Enemies of the Peach. Yearbook U.S. Dept. Agric., 1905. Washington, 1906, pp. 325-348, pls. xxvii-xxxiii.
- Rogers, L. A.**—Preventing Molds in Butter Tubs. U.S. Dept. Agric., Bur. of An. Indus, Bull. No. 89, 1906, pp. 1-13, 1 text fig.
- Sanderson, E. D.**—Report on miscellaneous cotton insects in Texas. U.S. Dept. Agric., Bur. Entom., Bull. No. 57, 1906, pp. 1-63, 33 text figs.

- Shamel, A. D.**—The Effect of Inbreeding in Plants. Yearbook U.S. Dept. Agric., 1905. Washington, 1906, pp. 377-392 plts. xlii-xliv.
- Theobald, F. V.**—Some Notable Instances of the Distribution of Injurious Insects by artificial means. Sci. Prog. 1906, pp. 1-15, figs. 1-3.
- Webster, F. M.**—Farm Practice in the Control of Field-Crop Insects. Yearbook U.S. Dept. Agric., 1905. Washington, 1906, pp. 465-476, plts. liv, lv.
- Webster, F. M.**—The Slender Seed-Corn Ground Beetle. (*Clivina impressifrons*, Lec.) U.S. Dept. Agric., Bur. of Entom., Circ. No. 78, 1906, pp. 1-6, 2 text figs.
- White, G. F.**—The Bacteria of the Apiary with special reference to Bee diseases. U.S. Dept. Agric., Bur. of Entom., Tech Ser. No. 14, 1906, pp. 1-50.

V.—FORESTRY.

Fisher, W. R.—Dr. Schlich's Manual of Forestry. Volume iv. Forest Protection. 2nd ed. Pp. xxiii + 712, and 300 text figs. London: Bradbury, Agnew & Co., Ltd., 1907, Price 12s. net.

This work, as is stated on the title page, is an English adaptation of Dr. Richard Hess' well-known "Der Forstschutz," and it speaks much for the author of the English edition, issued in 1895, that a second one has also become necessary.

In the present edition much additional matter has been added, including a short biographical notice of Hess and portrait, also a number of excellent figures.

It is a splendid work, in spite of the fact that the portion devoted to injurious forest insects is somewhat weak, otherwise the sections devoted to animals and plants injurious to forests are admirable. Professor Fisher is to be congratulated on having provided the British student with an excellent text book, and the student on having realised the fact.

W. E. C.

- Gillanders, A. T.**—Practical Notes on a few Northumbrian Forest Insects. Q. Journ. Fores., 1907, vol. i, pp. 27-32.
- Hill, J. S.**—A Note on the Sawfly attacking Larch Disease in Cumberland (*Nematus erichsonii*). Q. Journ. Fores., 1907, vol. i, pp. 67-70.
- Hopkins, A. D.**—Insect Enemies of Forest Introduction. Yearbook U.S. Dept. Agric., 1905. Washington, 1906, pp. 249-256, 9 text figs.
- Hopkins, A. D.**—Some Insects Injurious to Forests, The Locust Borer (*Cyllene robiniae*, Forst.). U.S. Dept. Agric., Bur. of Entom., Bull. No. 58, pt. i, 1906, pp. 1-16, plt. i, and 6 text figs.
- Hopkins, A. D.**—Pinhole Injury to Girdled Cypress in the South Atlantic and Gulf States. U.S. Dept. Agric., Bur. of Entom., Circ. No. 82, 1907, pp. 1-4, 1 text fig.

Webb, J. L.—Some Insects Injurious to Forests. The Western Pine—destroying barkbeetle. (*Dendroctorus brevicornis*, Lec.). U.S. Dept. Agric., Bur. of Entom., Bull. No. 58, pt. ii, 1906, pp. 17-30, pls. ii, iii, and 6 text figs.

VI.—FISHERIES.

Johnstone, J.—Internal parasites and Diseased Conditions of Fishes. Proc. L'pool. Biol. Soc., 1906, vol. xx, pp. 239-323, figs. 11-23.

VII.—MEDICINE.

Balfour, Andrew.—Second Report of the Wellcome Research Laboratories at the Gordon Memorial College, Khartoum. Pp. 255, 21 pls. and 106 text figs. Khartoum: Department of Education, Sudan Government, 1906.

It is quite impossible in the space at our disposal to do justice to this well printed and beautifully illustrated report. Dr. Balfour and his staff are to be congratulated on the excellent work which they are doing, and the manner in which they are recording the results of their investigations.

The first fifty pages are devoted to an Introduction, an account of the mosquito work in Khartoum and the Anglo-Egyptian Sudan generally, and of the biting and noxious insects other than mosquitoes. Mr. E. E. Austen contributes an account of some bloodsucking Diptera, with description of new species, and Mr. Theobald has a short report on Economic Entomology. Other reports deal with a Haemogregarine of Mammals, and a Leucocytozoon, and Trypanosomiasis in the Anglo-Egyptian Sudan, while Mr. Sheffield Neave's report of the travelling pathologist and naturalist, and one from Mr. William Bean from the chemical laboratory, bring to a close a volume full of valuable and interesting matter.

Braun, Max.—The Animal Parasites of Man. Translated from the German by Pauline Falcke and edited by L. W. Sambon and F. V. Theobald. Pp. xix + 453, and 294 text figs. London: John Bale Sons & Danielsson, Ltd., 1906. Price 21s. net.

Braun's work has long been known and appreciated by students of parasitology, but the rapid strides the subject has made in recent years makes it necessary that a work of this character should be constantly revised. This has been done by Messrs. Sambon and Theobald, who have added a large amount of new matter, so that the English edition is now one of the most useful works on the subject we know of.

Should a further English edition be called for, we would suggest the revision and amplification of the Bibliographic references.

W. E. C.

Henkel, Alice.—Wild Medicinal Plants of the United States. U.S. Dept. Agric., Bur. of Plant Indus., Bull. No. 89, 1906, pp. 1-76.

- Minchin, E. A., Gray, A. C. H., and the late F. M. G. Tullock.**—*Glossina palpalis* in its relation to *Trypanosoma gambiense* and other Thypanosomes (Preliminary Report). Proc. Roy. Soc., 1906, Ser. B., vol. 78, pp. 242-258, pls. 12-14, and 11 text figs.
- Minchin, E. A.**—The Breeding Habits of the Tsetse-fly. Nature, 1906, Oct. 25th, pp. 636.
- Minchin, E. A.**—The Etiology of Sleeping Sickness. Ibid., Nov. 15th, pp. 56-59.
- Quayle, H. J.**—Mosquito Control Work in California. Calif. Univ. Agric. Exp. Stat. Bull. No. 178, 1906, pp. 1-55, figs. 1-55 and 2 maps.

VIII.—VETERINARY.

- Craig, R. A.**—Diseases of Swine, with Special Reference to the Preventive Measures of Disease. Pp. vii + 191, and 23 text figs. New York: Orange Judd Co. London: Kegan Paul & Co., 1906.

As the author points out, the literature bearing on diseases of swine is very scattered, and in no other class of farm animals is so little attention given to preventive measures of disease, and as a result the percentage of loss is about twice as great as in other species.

The work is divided into four parts, Part 1 treating of General Diseases, Part 2, Surgical Diseases, Part 3, Infectious Diseases, and Part 4, Parasitic Diseases. The information is up-to-date, concisely put, and above all, practical.

W. E. C.

- Mayer, A.**—The Cattle Tick in its Relation to Southern Agriculture. U.S. Dept. Agric., Farmers' Bull. No. 261, pp. 1-22.
- Neumann, L. G.**—Sur la Filaire claviforme (*Filaria clava*, Weld.) du Pigeon domestique. Rev. Vétérinaire, 1906, pp. 661-664, figs. 1, 2.
- Newell, W., and Dougherty, M. S.**—The Cattle Tick (*Boophilus annulatus*). Circ. No. 10, State Crop Pest Comms. Louisiana, 1906, pp. 1-32, 8 text figs.
- Ransom, B. H.**—How Parasites are Transmitted. Yearbook U.S. Dept. Agric., 1905. Washington, 1906, pp. 13-166, 9 text figs.
- Ransom, B. H.**—Some unusual host relations of the Texas Fever Tick. U.S. Dept. of Agric., Bur. of An. Indus., Circ. No. 98, 1906, pp. 1-8.
- Salmon, D. E., and Smith, Theobald.**—Actinomycosis, or Lumpy Jaw. U.S. Dept. Agric., Bur. of An. Indus., Circ. No. 96, 1906, pp. 1-10.
- Salmon, D. E.**—Tuberculosis of the Food-producing Animals. U.S. Dept. Agric., Bur. of An. Indus., Bull. No. 38, 1906, pp. 1-99, pls. i-ix.
- Schroeder, E. C., and Cotton, W. E.**—Experiment with Milk artificially infected with Tubercule Bacilli. U.S. Dept. Agric., Bur. of An. Indus., Bull. No. 86, 1906, pp. 1-19.

Schroeder, E. C., and Mohler, J. J.—The Tuberculin Test of Hogs and some methods of their Infection with Tuberculosis. U.S. Dept. Agric., Bur. of An. Indus., Bull. No. 88, 1906, pp. 1-51.

IX.—COMMERCIAL.

Duerden, J. E.—Ostrich Feather Investigations. Farm and Stock Yearbook, S. Afr. 1907, 4 pp. (Reprint).

Palmer, T. S.—Federal Game Protection. A Five Years' Retrospect. Yearbook U.S. Dept. Agric., 1905. Washington, 1906, pp. 541-562, pl. lxx, 13 text figs.

Pickrell, W.—Ostrich Farming in Arizona. Yearbook U.S. Dept. Agric., 1905. Washington, 1906, pp. 399-406, plts. xlv-xlvii.

The Journal of Economic Biology.

VOLUME I, PT. 4, NOVEMBER, 1906.

Errata et corrigenda.

- p. 162 line 19 from top for "segments fine with" *read* "segments with fine."
 p. 164 for "temperatures and month as above" *read* "temperatures as above during August."
 p. 164 line 2 from bottom for "In was in" *read* "It was in."

THE
JOURNAL OF ECONOMIC BIOLOGY.

PARTHENOGENESIS IN *LOPHYRUS PINI*.

By

R. STEWART MACDOUGALL, M.A., D.Sc., F.R.S.E.

WITH PLATE V.

INTRODUCTION.

Lophyrus pini, the Pine Sawfly, lays its eggs on young Pine trees, especially on Scots Pine and Austrian Pine. The caterpillars, feeding in companies, are often the cause of much destruction. Not only are the leaves eaten to the midrib, and, it may be, down almost to the dwarf shoot, but the bark of the shoots is also gnawed away.

Male and female are easy to distinguish. The male is black, with apex of abdomen reddish and with white spots on the under side of the first segment. The antennae are doubly pectinate. The wing expanse is 15 mm. ; and the edges of the hind wings have a dark border.

The female is dull yellow in colour, with the head, three dark areas on the thorax, and the middle of the abdomen black. The antennae are bristle-like. The wings are yellowish, with darker edges. The wing expanse is about 20 mm. The larva measures nearly an inch when full grown, and, like all the larvae of the genus *Lophyrus*, has 22 legs. The colour varies at different stages in the caterpillar's growth. First of all the caterpillar is pale green, with yellow-brown head and black sucker feet ; later it is dull green, with the head dark brown and the sucker feet yellow ; along each side are dark marks.

The cocoons vary somewhat in colour, some are lighter, some darker ; they measure about one-quarter of an inch in length, and the adult issues by a lid opening at one end.

LIFE-HISTORY.

Typically, there are two generations in the year. The first brood of sawflies issues from the end of April onwards. The eggs are laid in rows, in slits cut in the needles by the saw-like processes common to the sawflies. The larvae from these eggs have a life of about two months, when pupation takes place in cocoons attached to the plant, or in the soil or undergrowth. The adults from these cocoons lay eggs, the larvae from which feed till autumn, when, full-fed, they leave the trees and spin cocoons in the soil. These cocoons are harder and thicker than the summer cocoons. Under cover of the cocoon, the caterpillar lies over winter, not pupating till the next spring.

While the foregoing life-history is typical, there is much overlapping among individuals of different broods, and even of the same brood. There may indeed be only one generation in the year, caterpillars full-grown in July lying sheltered in their cocoons until the next spring, when they pupate.

Parthenogenesis, or reproduction without fertilisation, is a phenomenon not unfamiliar in the world of insects. Whilst examples are found in the Micro-Lepidoptera, and in Thysanoptera, parthenogenesis is a feature amongst Aphides, and is familiar in the Hymenoptera.

The progeny resulting from the virgin eggs may be entirely of the male sex, or entirely of the female sex, or there may be a mixture of males and females. All three conditions are represented in the *Tenthredinidae*, or Sawflies.

In the winter of 1904-05 I obtained abundant material of the cocoons of *Lophyrus pini*, the Pine Sawfly. This material I kept over winter, and in the beginning of April, 1905, arranged it as follows. Each cocoon was placed under an inverted glass-tube, so that the adult Sawfly, on issuing, would be completely isolated. The males, on appearance, were placed in spirit; the females were saved for experiment.

The dates of issue of the adults from material collected about the same time are worth recording, as showing the possible variation in flight-time. The cocoons have been kept not in the open but in my room.

Date of issue.	Number of individuals.	Sex.
April 13	2	female
" 14	1	"
" 16	1	"
By " 24	5	"
" 27	7	6 females and 1 male
" 28	1	female
" 30	1	male
May 2	2	female
" 4	1	"
" 6	1	"
" 18	3	2 females and 1 male
" 19	1	female
" 20	1	"
" 25	1	"
" 27	2	female; an ichneumon also issued
" 29 & 30	21	19 females and 2 males (a Tachinia Fly also issued)
" 31	1	female
June 2 & 3	7	"
" 4	3	"
" 3 to 17	26	19 females and 7 males (2 Tachinia Flies also issued)
" 18	9	female
" 19	2	"
" 20	3	"
" 22	2	"
" 24	2 Tachinia flies issued	
July 5	1	male
" 8 to 15	5	female
" 16	3	"
" 17	1	male
" 21	1	female
August 1	1	male

i.e., 101 females and 15 males.

METHOD OF EXPERIMENT.

In each case the Pines used for experiment were healthy 4 to 6-year-old Scots Pine or Austrian Pine. Each Pine was potted in a large flower-pot, in the soil of which stakes were sunk, the stakes supporting over them and round the plant a muslin sack, which was open at both ends. The muslin sack was then slipped over the plant and secured tightly below the rim of the pot, and then closed above after the introduction of the virgin females.

At intervals the sacks were opened and observations made. The females of the species are sluggish, and remained undisturbed while their egg-laying was being watched under the lens.

Altogether, 23 Pines were used in the experiment. In some cases no eggs were found; in others eggs were laid, but no hatching was observed; in others eggs were laid and hatched, but I failed to rear the brood; while in others the resulting brood was successfully reared.

I give below some representative cases.

Pine 1.—Three females were placed on this Pine on April 14th. One was still alive on April 29th. No eggs were found.

Pine 2.—Two females were placed on this plant on April 16th. The females were alive at the end of a fortnight. Eggs were laid and caterpillars hatched, but I failed to rear the brood.

Pine 3.—On April 24th five females that had issued on this date were placed on the plant. All were alive on April 30th, when they were removed. There had been considerable egg-laying. The eggs hatched in due course, and during May numbers of young caterpillars were obtained.

On May 30th these were found to be growing well, the needles of the plant showing the characteristic damage. On May 31st another Pine was introduced, in order that food material might not be lacking. By the end of June the caterpillars were well grown. Between July 1st and July 8th four spun their cocoons. These four cocoons were laid aside, and yielded—

- (1) A male on July 21.
- (2) A male on July 22.
- (3) A male on July 23.
- (4) A male on July 24.

i.e., from the time of the introduction of the females three months had been taken to complete the life-cycle, the progeny from the virgin eggs being males.

Pine 4.—At least six needles of this Pine had rows of eggs laid on them, but the Pine died before any hatching was seen.

Pine 5.—Seven females were enclosed with this Pine on May 30th. By the 3rd of June many eggs had been laid. Right on through July this plant remained healthy, but no caterpillars were found.

Pine 6.—On June 17th, seven newly-issued females were enclosed with a 6-year-old Austrian Pine. Eggs were laid and duly hatched. For a time the caterpillars made progress, but the death of the plant terminated their life.

Pine 7.—I enclosed with a young Scots Pine six females on July 19th. By July 21st and succeeding days I found eggs. All the females were removed on July 26th, when at least 12 needles showed the characteristic rows of eggs. The eggs hatched, and by the middle of August there were many feeding caterpillars, the frass being very evident. Till this time the Pine had been standing in the garden under cover of an open tent (for protection against the wind, which in a previous experiment had played havoc with the muslin covers). The plant was now brought into the laboratory and placed at a window. By September 13th the plant was eaten practically bare. I removed it, and placed the caterpillars on two other Pines, a 3-year-old Scots Pine and a larger 5-year-old Austrian Pine. By September 26th the last Scots Pine was defoliated, and was removed and replaced by a new Austrian Pine. The caterpillars were now so numerous and large that, in order to prevent possible straying through the thin muslin, I removed the muslin and surrounded the two Austrian Pines with a large sack made of cotton.

I obtained the first cocoon on September 26th. On September 27th two other cocoons were made. By September 29th there were 17 cocoons. On September 30th 47 additional cocoons were obtained, while there still remained a number of feeding caterpillars.

The plants in which the caterpillars were still feeding were kept in a room without a fire. On October 7th I removed the cotton sack, ending this part of the experiment with 123 cocoons in all.

Fifteen caterpillars still remained; these I placed in spirit.

The cocoons were kept over the winter indoors. In Spring, 1906, now and again I opened a cocoon, and right into May found that the enclosed caterpillars had not yet pupated. On the 1st of June the adults began to come away, and the record is as follows:—

Date of issue of adult.	Number.	Sex.
June 1	2	male
" 2	2	"
" 3	3	"
" 4	2	"
" 5	3	"
" 6	6	"
" 7	1	"
" 8	14	"
" 9	4	"
" 10	11	"
" 11	9	"
" 12	7	"
" 13	2	"
" 14	4	"
" 15	3	"
" 16	2	"
" 21	2	"
" 23	1	"
" 27	1	"
" 28	2	"
July 5	2	"
" 7	2	"
" 8	1	"
" 9	2	"
" 10	1	"
" 12	2	"
" 14	1	"
" 15	2	"
betw'n " 18 & 26	4	"
" 30	1	"
" 31	3	"

i.e., 102 adults issued, all males.

I had to be away for a month, and before going opened the remaining cocoons, all of them held males.



Figs. 1 & 2 after Henschel,
the rest from nature.

LOPHYRUS PINI, Curtis.

EXPLANATION OF PLATE V.

Illustrating Dr. R. Stewart MacDougall's paper on "Parthenogenesis in *Lophyrus pini*."

Fig. 1.—*Lophyrus pini*, male. After Henschel.

Fig. 2.—*Lophyrus pini*, female. ditto

Fig. 3.—Austrian Pine with larvae of *Lophyrus pini*.

Fig. 4.—Austrian Pine showing needles destroyed by the larvae, also the moulted skins of three larvae.

Fig. 5.—Austrian Pine with cocoons of *Lophyrus pini*.

Fig. 6.—Piece of branch of *Pinus sylvestris* with bark gnawed away by the larvae.

Fig. 7.—Needles of Austrian Pine eaten by the larvae.

Fig. 8.—Needles of *Pinus sylvestris* eaten by the larvae.

Fig. 9.—Part of branch of Austrian Pine showing the result of the feeding of the larvae.

The figures 3-9 are all drawn natural size.

ON THE LIFE-HISTORY OF THE ROOT MAGGOT, *ANTHOMYIA RADICUM*, MEIGEN.

By

C. GORDON HEWITT, M.Sc.,

Lecturer in Economic Zoology in the University of Manchester.

WITH PLATE VI.

INTRODUCTION.

SLINGERLAND,¹ in his account of the Cabbage Root Maggot, *Phorbia brassicae*, Bouché, refers to the allied species, *Anthomyia radicum*, as follows:—"Although this insect has been known for more than a century (it was described by Linneus in 1761), our knowledge of its life-history is very indefinite and meagre." As *A. radicum* is extremely common in this country, to some this lack of knowledge concerning its life-history may seem strange. In another memoir I have referred to its occurrence in houses with *M. domestica*; this inclusion in the species of flies found in houses renders a knowledge of the life-history of *A. radicum* a great desideratum. Also considerable trouble has been caused in the past by the confusion of this species with the Cabbage Root Maggot, *Phorbia (Anthomyia) brassicae*, any facts, therefore, which would assist in elucidating this confusion seemed to me to be desirable. For these reasons, then, the following account has been written of some breeding experiments which were made during the summer of 1906 in the Zoological Department of this University.

HISTORICAL.

In 1834 Bouché² gave the first account of the life-history of *Anthomyia radicum*, and apparently the accounts of the life-history which have been given by various authors since that date have been taken from Bouché's account. He describes the larva as being muricate, and as occurring in thousands in human excrement. The prothoracic stigmata possesses 7 to 10 divisions. The larval period lasts from eight to twelve days, and the pupal state two to three weeks.

¹ "The Cabbage Root Maggot, with notes on the Onion Maggot and allied insects. Bull. 78. Cornell Univ. Agricult. Expt. Stat. Entom. Div., 1894.

² Bouché, P. Fr., 'Naturgeschichte der Insekten besonders in Hinsicht ihrer ersten Zustände als Larven und Puppen. 216 p., 10 pl. (*A. radicum*, p. 75-76).

Curtis, in 1843,¹ and in his "Farm Insects" (1860), described the larva and the adult. Some later writers have obtained their descriptions from Curtis' account, but the insect which he describes appears to be the Cabbage Root Maggot, *Phorbia brassicae*, and not *Anthomyia radicum*. Taschenburg, in his "Praktische Insektkunde,"² takes his account of the life-history of the insect from Bouché. He also adds that the larva of the "Wurzelfliege" lives in the roots of species of *Raphanus* and *Brassicae*, and recommends as a remedy the use of superphosphate, which not only prevents the attacks of the larvae, but also prevents the female flies from laying their eggs in the locality on which it is used. Saunders³ bred this species from young cabbages, and it is described as a turnip pest by Fyles⁴ in 1890. Goff,⁵ in 1885, gave an account of his experiments on the eradication of the pest by means of carbon-bisulphide. I have been unable to discover any addition to our knowledge of the life-history of the species since Bouché's original account.

DISTRIBUTION.

Anthomyia radicum is a European species. Schiner⁶ describes it as "allenthalben sehr gemein." In England I have found it very abundant, and have found it as common as *M. domestica* in some houses. In view of the enormous commercial intercourse between this country and America, the rarity of this species in North America is very remarkable. I am indebted to Prof. Slingerland for the following account of the distribution of *A. radicum* in that country. It has been recorded in Greenland and in Alaska by Holmgren, Coquillet, and Lunbech in Aldrich's Catalogue of American Diptera. Stein⁷ records its occurrence in Indaho, New York, Ontario, Massachusetts, and Pennsylvania. The authenticity of the records of its occurrence in New Jersey by Smith, in the White Mountains, N.H., by Slosson, and in the Province of Quebec by Fyles is doubtful. Prof. Slingerland says: "If the insect really occurs in this country it must be quite rare."

LIFE-HISTORY.

The eggs were deposited in bright sunlight on masses of horse-manure, which had been placed in the wire-gauze cages in which the

¹ Curtis, J., Journ. Roy. Agr. Soc. of Eng., 1843, vol. 4, p. 127-131.

² Taschenburg, E. L., 'Praktische Insektkunde,' 1880, vol. 4, p. 131-132.

³ Saunders. Canadian Entom., vol. 12, p. 212.

⁴ Fyles. Rep. Ont. Entom. Soc., 1890, p. 44.

⁵ Goff. 3rd Rep. New York State Agr. Exp. Station, p. 316, 1885.

⁶ Schiner. Fauna Austriaca. Die Fliegen, vol. 1, p. 645, 1862.

⁷ Stein. Berl. Entom. Zeitschr., vol. 42, p. 208.

flies were confined. It was necessary to supply them with freshly-deposited faeces, as they generally refused older faeces, especially if they had been broken up. In ovipositing the flies crawled down as far as possible between the faecal masses and inserted their ovipositors into the crevices. The eggs were deposited in masses, as many as 20 or 30 eggs occurring in a single cluster; a single fly, however, is capable of depositing three times this number of eggs.

The egg of *A. radicum* (Fig. 1) is 1.3 mm. long, convex on the ventral, and almost straight on the dorsal side. The colour is a pearly white. The surface of the egg is marked by a regular sculpturing of minute hexagons; on the side of the egg, which is slightly concave, a pair of folds extends from the micropyle almost to the opposite end, where they meet, forming a broad groove.

The larvae emerged from 18 to 36 hours after the eggs had been deposited, the egg-case splitting longitudinally along the middle of the groove. The newly-hatched larvae measure almost 2 mm. in length. They do not possess prothoracic stigmata, but are metapneustic, a pair of stigmata being situated on the oblique posterior extremity, each of these stigmata possesses two openings. During the second day they undergo the first ecdysis. The larva of the second larval stadium possess a pair of prothoracic stigmata, situated at the sides of the posterior end of the post-cephalic or prothoracic segment; each of the prothoracic stigmata is divided into thirteen lobes (Fig. 9). As in the first instar, each of the posterior stigmata situated on the obliquely truncated posterior end possesses two slits, as shown in Fig. 8, these slits being guarded by inwardly projecting dendritic processes of the chitinous rings surrounding them. Each of the posterior spiracles is raised above the posterior surface, so that they form a pair of blunt projections (Fig. 2, *p. sp.*). The adanal lobes of the second instar are large. A second ecdysis takes place about 48 hours after the first; the third instar is the last larval stadium.

The full-grown larva (Fig. 2) measures 8 mm. in length. It is cylindrical, gradually tapering off from the eighth segment to the anterior end, the posterior end being obliquely truncate. The colour is yellowish-white, but as the cuticle is muricate the larva has generally a dirty appearance, owing to adherence of particles of dirt. The three anterior of the twelve segments composing the post-cephalic portion of the larva have the spines confined to their anterior ends where they surround the segments; these spines are arranged in regular linear groups. On the remaining segments of the body the spines are scattered. Each of the nine posterior segments has at the anterior end of its ventral side a crescentic fold, which is covered with short, closely-set spines; these spinous pads form the organs of locomotion. Each

of these segments is marked by one or more incomplete annulations. The posterior end of the larva (Fig. 3) is surrounded by six pairs of spinous tubercles; a seventh pair is situated on the ventral surface posterior to the anus, between the latter and the oblique posterior surface. The arrangement of the tubercles can be best understood by reference to the figure. Counting from the dorsal side, the fifth pair of tubercles is situated slightly inside the circle of the four more dorsal pairs. The tubercles of the sixth pair differ from the rest in being smaller and bifid, in which character they resemble those of *Phorbia brassicae*, but differ, however, from the corresponding caudal tubercles of the Onion Maggot, *Phorbia ceparum*, Meigen, where they are single-pointed like the rest. The bifid pair of tubercles are situated internal to the fifth pair, and immediately below the posterior spiracles. The brown posterior spiracles (*P. sp.*) project above the posterior surface, each consists of three slits similar in character to those of the second instar. The prothoracic spiracles (Fig. 2, *pt. sp.*), which are light yellow in colour, consist of 13 lobes. Bouché gives 7 to 10 as the number of lobes, but I never found one possessing so few.

The third larval stadium lasts from five to eight days. The whole larval state may be passed in eight days, but the length of the larval period is controlled, as was determined by experiment, by several factors, chief of which were the temperature and moisture of the food. It was found that the development was accelerated by a high temperature, while a low temperature produced the opposite effect. This I also found to be the case with the larvae of *Musca domestica*.¹ Lack of moisture has a retarding influence on the development of the larvae, for unless the food is sufficiently moist the larvae are unable to take it in. The temperature during the breeding experiments was fairly warm, averaging about 78° F., consequently the experiments were made under favourable conditions as regards temperature. Some of the larvae which were hatched out later in the season took longer to develop. Bouché found that the larval period lasted from 8 to 12 days.

When the larva is full grown, after a short period of rest it pupates. In pupating the larva undergoes contraction, the anterior segments are contracted more than the rest, so that the prothoracic stigmata become situated at the anterior end. The larval skin forms the pupal case, which consequently retains the external larval characters in a shrunken condition. The pupa changes from a yellowish colour to a dark brown; the process of pupation lasts two or three hours.

The pupae vary slightly in size, the average size being 4.6 mm. in

¹ A Preliminary Account of the Life-History of the Common House-Fly (*Musca domestica*, L.) Manchester Memoirs, 1906, Vol. 51, No. 1.

length and 1.6 mm. broad. The prothoracic stigmata can be seen at the anterior end. At the posterior end the posterior stigmata are surrounded by a circle of small spines, representing the caudal tubercles of the larva. The length of time in the pupal stage varies considerably. The shortest time was ten to eleven days; some flies emerged two to four weeks after pupating. Bouché gives two to three weeks as the "nymph" state. I am inclined to believe that the insects are able to remain through the winter in the pupal state under suitable conditions, but all the flies emerged from my pupae before I was able to test this.

When the fly is ready to emerge, a circular split appears at the anterior end of the puparium between the second and third segments, and by the splitting of these anterior segments in the mid-lateral lines the fly pushes off the ventral half of the cap by means of the inflated ptilinum or frontal sac, which is withdrawn shortly after emergence.

The life-history of *A. radicum* may be summarised as follows:—

Egg Stage	18-36 hours.
Larval Stage—			
First larval stadium	...	24	hours.
Second " "	...	48	hours.
Third " "	...	5	days.
			8 days.
Pupal Stage	10 days.

The whole development from the deposition of the egg to the exclusion of the imago may be completed in about 19 to 20 days if the condition of the weather is fairly warm.

In a very hot spell of weather I believe the time of development would be even shorter still.

SUMMARY AND COMPARISON WITH LARVA AND LIFE-HISTORY OF *PHORBIA BRASSICAE*.

It will be useful perhaps if, in summarising the results of this study, they are compared with the results of Slingerland's investigation of the life-history of *Phorbia brassicae*.

The eggs differ in the character of the external sheath or chorion. The surface of the chorion of *A. radicum* is finely sculptured with small hexagons; it has a pair of folds running along the dorsal side and the anterior end of the egg is terminated by a slightly projecting micropyle. The surface of the chorion of *P. brassicae* is marked with an irregular series of longitudinal ridges, and a groove runs along the whole length of the egg, becoming deeper at the anterior end.

In *A. radicum* the eggs hatch in 18 to 36 hours; this was during warm weather, colder weather would no doubt have a retarding influence.

Slingerland was unable to breed *P. brassicae* from eggs in confinement, but states that Mr. P. H. Scudder informed him that the eggs hatched in 4 to 10 days, depending on the conditions of the weather. The larva of *A. radicum* emerges in a similar manner to that of *P. brassicae*, through a longitudinal split in the chorion. The larvae of *A. radicum* undergo two ecdyses during their larval life, so that three larval stadia can be recognized. Slingerland does not describe the different larval stages of *P. brassicae*, it is extremely probable that the larvae of this insect undergo two larval ecdyses.

The first larval stadium of *A. radicum* is characterized by the absence of prothoracic stigmata; it lasts about one day. The second instar, in addition to the posterior pair of stigmata, each with a pair of oblique, slit-like apertures, possesses prothoracic stigmata. This stadium lasts about two days. The third larval stadium lasts from five to eight days. The third larval instar possesses posterior stigmata having three slit-like apertures. In both the second and third instars the prothoracic stigmata are divided into 13 lobes. The prothoracic stigmata of *P. brassicae* possess 12 lobes; no mention is made of the character of the posterior stigmata.

In general appearance the larva of *A. radicum* resembles that of *P. brassicae*, but the two species may be distinguished by the character of the tubercles surrounding the oblique posterior end. In the former species the caudal tubercles, which have bifid extremities, are small, and are placed internal to the circle formed by the remaining tubercles; in the latter species they are longer and more ventral in position.

The whole larval state of *A. radicum* may be passed in eight days under favourable conditions. Bouché states that the larval state of *P. brassicae* last from 3 to 4 weeks; Slingerland gives no definite evidence on this point, but states that Mr. Whitehead says from 24 to 28 days. He is inclined to believe that the larvae may attain maturity in less than three weeks.

The pupae of the two species are similar in character, but, as the puparium is the dried larval skin on careful examination, the distinguishing characters of the tubercles at the posterior end and the lobes of the prothoracic stigmata can be observed. The pupal stage of *A. radicum* lasts from ten days to several weeks. Thus the whole development may be completed under favourable conditions in 19 to 20 days. Bouché gives the larval life of *P. brassicae* as 3 to 4 weeks, and the "nymph" state 2 to 3 weeks, making the whole development from egg to imago 5 to 7 weeks. Slingerland believes that the egg, larval and pupal stages, may be passed in less than 41 days, but unfortunately he was unable to obtain precise information. Only those who have conducted experiments on the breeding of the larvae of flies are

acquainted with the great difficulty attending such operations; one soon becomes painfully aware of the fact that these ubiquitous insects refuse to have their natural habits interfered with by man.

THE CEPHALO-PHARYNGEAL SKELETON.

At each of the larval ecdyses the cephalo-pharyngeal skeleton becomes stouter in build. In the first half of the second larval stadium the structure of the skeleton is as follows (Fig. 5).

Between the labial lobes there are two rather slender chitinous mandibular sclerites (*md.s.*); with hooked distal ends. They lie parallel, and are attached by their proximal ends to the U-shaped hypostomal sclerite (*n.s.*). A pair of irregular dentate sclerites (*d.s.*) articulate with the ventral sides of the posterior half of the mandibular sclerites. The U-shaped hypostomal sclerite lies in the horizontal plane, and has the two processes directed backwards, each resting between two processes of the cephalo-pharyngeal sclerite of that side. The cephalo-pharyngeal sclerites (*l.c.p.*) lie one on each side of the pharynx. They are united by an anterior dorsal perforate sclerite (*pf.s.*). At the anterior end each cephalo-pharyngeal sclerite is produced ventrally to form two processes, between which one of the arms of the hypostomal sclerite is attached. The posterior end of each sclerite is deeply incised, so that a dorsal (*d.p.*) and a ventral process (*v.p.*) are formed; each of these processes is again incised to form a larger process subtended by a smaller one. In the second half of the second larval stadium a pair of thin sclerites (Fig. 6, *m.sh.*) appear. They are formed by the thickening of the cuticle on the inside of the labial or cephalic lobes, and seem to be of the nature of sheaths for the mandibles. Their occurrence is interesting, as they are not present during the first half of the second larva stadium.

The cephalo-pharyngeal skeleton of the third instar, that is, of the mature larva (Fig. 7) has a stouter appearance. The mandibles are a pair of stout hooked sclerites (*md.s.*), each being perforated near the base by a fine pore. A pair of irregular sclerites (*d.s.*), representing the dentate sclerites of the previous stage, articulate with the base of the mandibular sclerites. The latter articulate with the stouter hypostomal sclerite (*h.s.*), which in turn unites with the cephalo-pharyngeal sclerites; these, though stouter in build than the cephalo-pharyngeal sclerites of the earlier larva, present the same characters.

After the exclusion of the imago the cephalo-pharyngeal skeleton of the larva remains attached to the dorsal side of the empty puparium.

I wish to gratefully acknowledge the assistance of Mr. H. S. Leigh in making preparations of some of the larval stages.

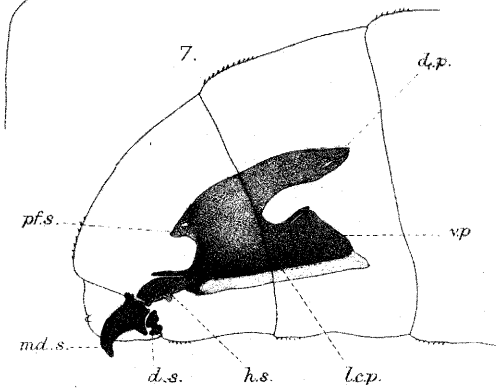
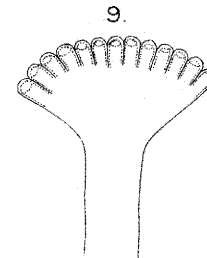
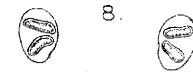
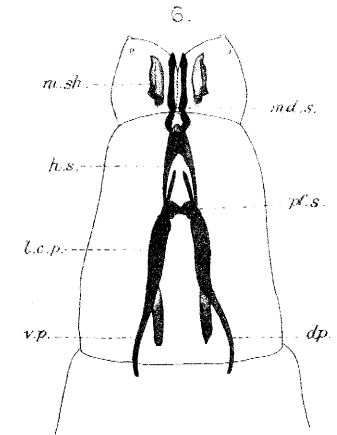
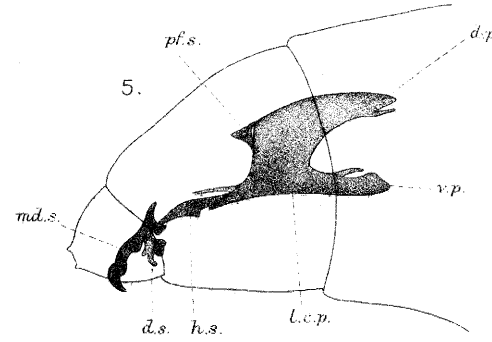
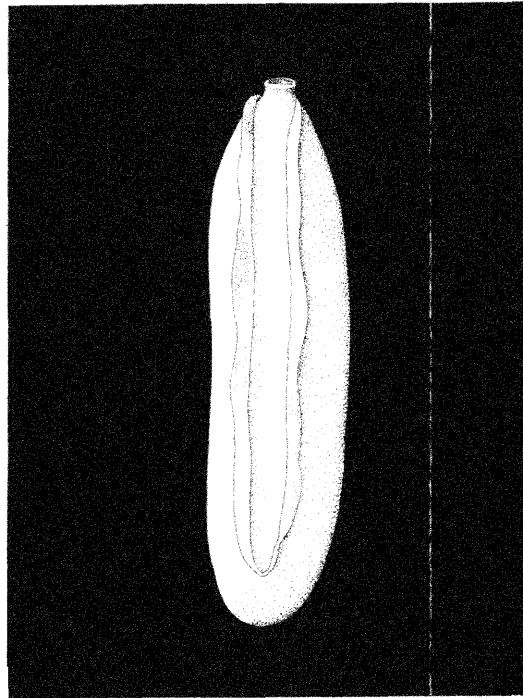
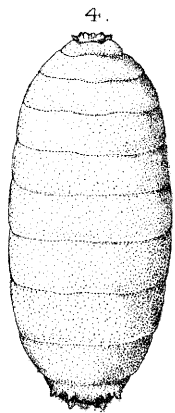
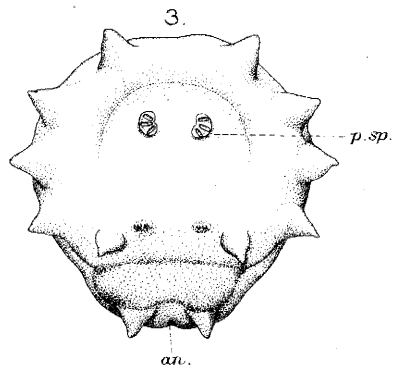
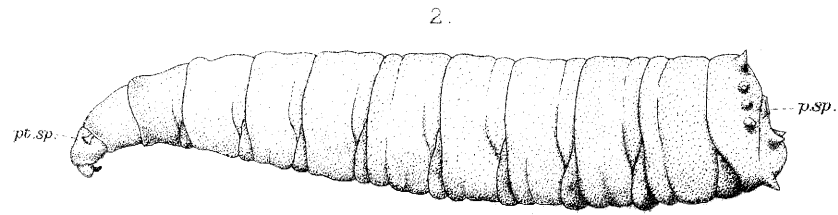

EXPLANATION OF PLATE VI.

Illustrating Mr. C. Gordon Hewitt's paper "On the Life-history of the Root Maggot, *Anthomyia radicum*, Meigen."

Fig. 1.—Dorsal view of egg of *Anthomyia radicum*. × 55.

Fig. 2.—Mature larva of *A. radicum*. × 12.

pt. sp. prothoracic spiracle; *p.sp.* posterior spiracle.

Fig. 3.—Posterior end of same to show the arrangement of the caudal tubercles and the posterior stigmata or spiracles (*f. sp.*). *an.* anus.

Fig. 4.—Pupa of *A. radicum*—dorsal aspect. × 11.

Fig. 5.—Cephalo-pharyngeal skeleton of larva of the first half of the second larval stadium. These figures of the cephalo-pharyngeal skeleton are camera lucida drawings of preparations which have been made by means of caustic potash in the ordinary manner, so that other anatomical details are omitted.

d.p. dorsal process of cephalo-pharyngeal sclerite;

d.s. dentate sclerite; *h.s.* hypostomal sclerite;

l.c.p. cephalo-pharyngeal sclerite; *m.d.s.* mandibular sclerite:

p.f.s. perforate sclerite; *v.p.* ventral process of cephalo-pharyngeal sclerite.

Fig. 6.—Cephalo-pharyngeal skeleton of larva of second half of the second larval stadium seen from above to show the mandibular sheaths, *m.sh.* Other lettering as in Fig. 5.

Fig. 7.—Cephalo-pharyngeal skeleton of mature larva of *A. radicum*. Lettering as in Fig. 6.

Fig. 8.—Posterior stigmata of the larva (2nd instar) of *A. radicum*.

Fig. 9.—Prothoracic stigma of mature larva.

A REMEDY FOR THE SPRUCE GALL AND LARCH BLIGHT DISEASES CAUSED BY CHERMES.

By

E. R. BURDON, M.A., F.L.S.,

Curator of the Botanical Museum, Cambridge.

IN the last number of this Journal¹ I gave a general outline of the life-history of the genus *Chermes*, which causes the well-known Pine apple galls on the Spruce, and the blight on the Larch, Pine, and Silver Fir.

The damage done by these pests was next discussed at some length, and it was clearly shown that not only is the direct injury caused by the insects of most serious import, but that they are also indirectly responsible for many of the other ills to which these trees are subject. The dreaded Larch canker (*Peziza willkommii*) and the Spruce shoot disease (*Septoria parasitica*) without doubt frequently gain entrance to the trees through the wounds made by "Chermes," while the presence in plantations of trees enfeebled by these diseases encourages the attacks of wood wasps and boring beetles.

The methods generally recommended for preventing the attacks of *Chermes* were then described, and it was shown that none of these could be regarded as anything more than a partial remedy.

Picking off the galls by hand is an operation which, unless very carefully carried out, may cause almost as much injury to the trees as the galls themselves, and it is no use trying to exterminate the insect on the Spruce unless neighbouring Larches, Pines, and Silver Firs are also cleaned at the same time. In any case it would be almost impossible to apply this method to a large plantation.

Recommendations for spraying the trees *in spring or summer* are almost invariably qualified with a warning as to the liability of the wash to scorch the foliage, which would make owners of plantations hesitate to carry out the operation. Apart from this, spraying at this time of the year would have no effect on the *offspring* of the winter mother which had already entered the galls.

I suggested that spraying the trees in winter might be a solution of the case, and described some trial experiments which I had made

¹ Journ. Econ. Biol., 1907, vol. ii, p. 1-13.

in this direction. These trial experiments were on a very small scale, and merely consisted of dipping infected branches into various washes, but I got very encouraging results from an emulsion of soft soap and paraffin.

At the beginning of this year I continued these experiments on a somewhat larger scale, and a number of young Spruce Firs, varying from 5ft. to 20ft. in height, were sprayed with different washes. As a result of these experiments I can confidently state that trees attacked by *Chermes* can be perfectly cured by spraying them *during the winter* with an emulsion of soft soap and paraffin—and the method has the great merit that it in no way injures the trees. The buds at this time are well protected by the thick resinous bud scales, and the needles of the previous year are sufficiently hardened and matured to withstand being killed or scorched by the wash.

There is no necessity to give details of those washes which were not effective, and I will confine myself to describing the experiments which were successful. The following wash, which is a much stronger mixture than the wash described in my previous paper, was used:—

Wash No. 1.—Dissolve 3 lbs. soft soap in 2 quarts boiling water, add 1 pint paraffin to the above whilst still boiling, and churn the two together until they form a buttery mass. This stock is then diluted with 5 gallons soft water.

18th January, 1907. The following branches were then dipped into the wash tub and gently shaken in the fluid until all parts were thoroughly wetted:—

Branch No. 7 on Spruce marked B on which 23 hibernating *Chermes* were counted.

„	8	„	„	„	91	„	„
„	9	„	„	„	64	„	„
„	10	„	marked F	„	83	„	„
„	11	„	„	„	57	„	„
„	12	„	„	„	28	„	„
					346		

Thus 6 branches on two different trees, bearing a total of 346 hibernating *Chermes* were washed. On March 31st, when the *Chermes* on other branches of the same trees were seen to have awakened, the washed branches were examined, and all the *Chermes* on them were apparently dead. Examined again on June 13th, not a single gall was to be found on any of these branches.

Two trees which have been regularly galled year after year, and on which numbers of hibernating *Chermes* were found to be present, were sprayed with the same wash on January 18th. With the exception

of about half a dozen galls on branches which the spray failed to reach, both these trees are practically free of *Chermes*.

A further trial of this wash was made on five badly infected Spruces in the Cambridge Botanic Gardens, which Mr. Lynch, the Curator, kindly had sprayed at my request. The buds were just beginning to show signs of swelling, and there were numbers of *Chermes* seated below the buds, which had just awakened and commenced to suck.

On examining these trees on June 13th, I was unable to find a single gall, though other trees close beside them were laden with galls. No scorching of the foliage has occurred in any case.

Wash No. 2.—Another wash which also gave successful results consisted of a solution of soft soap mixed in the proportion of 1 lb. soft soap to 1 gallon of soft water.

A branch on which I counted some 80 to 90 *Chermes* was dipped into this solution on March 31st. The buds were just beginning to swell, and the insects were all awake and had commenced sucking. No galls whatever have developed on this branch, the young shoots have all grown out strong and healthy, and although a few of the last year's needles have turned brown and died, the majority are quite green and healthy, and what damage there is is hardly worth noticing.

Two Spruces, about 20ft. high, were also sprayed with this solution, and although there were plenty of insects awake and sucking at the buds at the time of spraying, I have been unable to find more than two or three galls on the trees, and the presence of these is accounted for by the trees being surrounded below by a clump of Box and Yew bushes, which prevented the spray from reaching all the buds.

It is evident from these experiments that the Pine-apple galls of the Spruce can be entirely prevented by spraying the trees before the buds begin to open—that is any time before the end of March—and that there is little risk of any injury to the foliage in such operation.

I am sorry to say that I had no opportunity of attempting any washing or spraying experiments on the Larch. At the end of March, when I had the time at my disposal, it was already too late, as the buds had begun to burst, and the tips of the needle tufts were already showing up green. Spraying the delicate young needles with washes of the strength used on the Spruce would have infallibly resulted in their being burnt, and I was forced to delay the operation until next year. But I am perfectly convinced in my own mind that trees which are thoroughly sprayed during the winter with the same mixture as I used for the Spruce Firs will be almost entirely freed from *Chermes* blight in the ensuing summer.

If it is possible to find some ingredient to add to the mixture which would at the same time destroy that most injurious insect, the Larch Leaf-mining Moth (*Coleophora laricella*), the double benefit thus conferred would be of the greatest value. The caterpillars of this insect, each encased in a little brown sack, formed of the empty shell of a leaf whose interior it has devoured, are to be found hibernating in hundreds at that time of year, fastened to the twigs or buds and concealed in crevices of the bark, and a wash which would destroy them at the same time as the *Chermes* would be of inestimable value. Protected as they are by their little empty leaf cases they are difficult to touch, but as they begin to wake very soon after the buds commence to swell it might be worth while adding some poison, such as arsenate of soda and acetate of lead, to the soft soap and paraffin emulsion, in the hope of destroying them along with the *Chermes*.

POST-SCRIPT.—After the above article had been sent to the press, a most interesting letter, entirely confirming the results of my own experiments, was received from the Director of the Royal Gardens at Kew. Mr. W. J. Bean, Assistant Curator at Kew, made, in the spring of the present year, a trial of the method recommended, and had the Spruce Firs sprayed before the opening of the winter buds. By the courtesy of Col. Prain, I am allowed to give the following quotation from Mr. Bean's report to him on the efficacy of the treatment:—

“The Spruces at Kew, hitherto very badly affected by *Chermes*, were early last April sprayed with an emulsion of paraffin and soft soap. The result is very marked: few galls indeed are to be seen this year.”

REVIEWS AND CURRENT LITERATURE.

I.—GENERAL SUBJECT.

Adams, H. Isabel.—Wild Flowers of the British Isles. Revised by James E. Bagnall. Pp. xv + 168, 75 col. pls. London: William Heinmann, 1907. Price 30s. net.

So many worthless books on wild flowers have been published during the past few years, that we welcome the beautifully printed and illustrated work before us.

Twenty-nine Orders are treated of, the rule followed being to give a short descriptive account of the Order, and then of the different species. In some cases those of the latter are exceedingly brief, but nevertheless clear.

The illustrations throughout are excellent. Well drawn, delicately coloured, and most natural, indeed we do not call to mind any similar work wherein they are surpassed.

The popular names are given throughout, followed by the scientific. This feature with the description of botanical terms and a good index make the work one of considerable value and interest, and we sincerely hope that it will meet with a reception that will induce the authors to prepare a second volume.

Both authors and publisher are to blame for having the plates numbered so small, and on the left-hand side.

W. E. C.

II.—ANATOMY, PHYSIOLOGY, AND DEVELOPMENT.

Folsom, Justus W., and Welles, Miriam U.—Epithelial Degeneration, Regeneration and Secretion in the mid-intestine of Collembola. Univ. Illinois Bull. 1906, vol. iv, no. 6., Univ. Studies, vol. ii, no. 2, pp. 5-40, pls. ii-ix.

The authors confirm the observations of Sommer and Fernald regarding the behaviour of the mid-gut epithelium in these Insects. It is found that the inner half of the epithelium, together with nearly half of the total number of nuclei, becomes separated off from the outer half by a membrane. The former half is cast off into the cavity of the gut and the latter regenerated. The authors believe the process to be an excretory one, since, by this means, "rapidly accumulating concretions of sodic urate are removed from the cells of the mid-intestine." This remarkable process is correlative with the absence of Malpighian tubes in the Collem-

bola. Among other features, the origin and mode of development of the pentrophic membrane is dealt with, and it appears to form by the splitting of the "Harschensaum."

A. D. IMMS.

Guthrie, J. E.—The Furcula in the Collembola. Proc. Ac. Sci. Iowa, 1907, pp. 69-73, plts. ii-v.

Guthrie, J. E.—Studies of the Collembolan Eye. Ibid., pp. 239-243, plt. xviii.

Hewitt, C. G.—A Preliminary Account of the Life-history of the Common House Fly (*Musca domestica*, L.). Mem. and Proc. Manchester Lit. Phil. Soc., 1906, vol. li, pp. 1-4.

Hill, E., and Haydon, L. G.—A Contribution to the Study of the Characteristics of Larvae of Species of *Anopheles* in South Africa. Ann. Natal Gov. Mus., 1907, vol. i, pp. 111-157, plts. xv-xxvi.

Hulst, Francis A.—The Histolysis of the Musculature of *Culex pungens* during Metamorphosis. Biol. Bull., 1906, vol. xi, no. 6, pp. 277-304, plts. x and xi.

The process appears to be a chemical one unaided by any physical action by cells situated outside the muscles. It is possible, however, that the process is aided by internal secretions of other cells in the body, which reach the musculature through a circulating medium. Phagocytes appear in the muscular detritus after a muscle is far degenerated, and they remove part of the necrotic tissue. The phagocytes are attracted by means of chemotaxis, they do not appear to be blood cells, but are probably derived from cells scattered through the connective tissue. The regeneration of the new muscles of the imago is from imaginal discs, by a proliferation of the embryonic cells which have persisted in an undifferentiated condition during larval growth.

A. D. IMMS.

Imms, A. D.—On the Larval and Pupal Stages of *Anopheles maculipennis*, Meigen. Journ. Hyg., 1907, vol. vii, pp. 291-318, plts. iv, v, 1 text fig.

An admirable piece of work which was badly needed. Much yet remains to be done on these lines amongst the different genera of *Culicidae*.

Jost, H.—Berträge zur Kenntnis des Entwicklungsganges der Larvae von *Hypodermis bovis*, De Geer. Zeit. f. wiss. Zool. 1907, Bd. lxxxvi, pp. 644-715, Taf. xxxii und 3 figs.

Reijnvaan, J., and van Leeuwen, W. D.—*Aulax papaveris*, Perris: Its biology and the development and structure of the gall which it produces. Marcellia, 1906, vol. v, pp. 137-151, 3 text figs.

Shelford, R.—The Larva of *Collyris emarginatus*, Dej. Trans. Entom. Soc., 1907, pp. 83-90, plt. iii.

Stephens, J. W. W., and Newstead, R.—The Anatomy of the Proboscis of Biting Flies. Part II. *Stomoxys*. Ann. Trop. Med. and Paras., 1907, vol. i, pp. 171-182, pls. xii-xix.

III.—GENERAL AND SYSTEMATIC BIOLOGY, AND GEOGRAPHICAL DISTRIBUTION.

Banks, N.—New *Oribatidae* from the United States. Proc. Ac. Nat. Sci. Philad., 1907, vol. lviii, pp. 490-500, pls. xiv-xviii.

Brodie, W.—Parasitism of *Carpocapsa pomonella*. 37th (1906) Ann. Rpt. Entom. Soc. Ontario, 1907, pp. 5-15.

Butler, E. J.—An Account of the genus *Pythium* and some *Chytridiaceae*. Mem. Dept. Agric. India, Bot. Ser., 1907, vol. i, no. 5, pp. 1-160, pls. i-x.

Caudell, A. N.—The *Decticinae* (A Group of Orthoptera) of North America. Proc. U.S. Nat. Mus., 1907, vol. xxxii, pp. 285-410, 94 text figs.

Cecconi, G.—Di alcune galle della Pineta di Ravenna descritte e figurate da Francesco Ginanni (1774). Marcellia, 1906, vol. v, pp. 162-165, fig.

Christophers.—On the Importance of Larval Characters in the Classification of Mosquitoes. Sci. Mem. Med. Dept. Govt. India, new ser., no. 25, pp. 18, 3 pls. Calcutta, 1906.

In this paper the characteristic features of most of the known Mosquito larvae are enumerated, and it is shown that, in general, genera based on adult characters are established still more firmly by taking the immature stages into account. In this way, however, many points are brought out which are not so evident on a consideration of adult characters alone. From a study of the characters afforded by the eggs, the larval antennae, the pupal trumpets and the scalification of the imago, the author suggests provisionally that *Stegomyia*, together with *Desvoidea*, should be united into a new sub-family the *Stegomyiina*. Furthermore he proposes to enlarge Theobald's group of the Megarhinina by including within it, besides *Megarhinus* and *Toxorhynchites*, the genera *Muscides*, *Psorophora*, and possibly *Janthinosoma*, *Lutzia*, and *Culex concolor* and *C. tigripes*; the two latter forms he proposes to unite into a new genus *Jamesia*.

A. D. IMMS.

Cooper, W. F., and Robinson, L. E.—Note on a new South African Tick, *Rhipicephalus phthirioides*, sp. n. Linn. Soc. Journ., Zool., 1907, vol. xxx, pp. 35-38, plt. 5.

The authors have advisedly distributed a privately printed series of figures. Those on plate 5 are very poor.

Dyar, H. G.—Report on the Mosquitoes of the Coast Region of California, with descriptions of new species. Proc. U.S. Nat. Mus., 1907, vol. xxxii, pp. 121-129.

- De Stefani Perez, T.**—A proposito della galla di *Mangifera indica*, L., recentemente descritta. Marcellia, 1906, vol. v, pp. 165, 166.
- De Stafani, T.**—A proposito di alcune Galle dell' erbario secco del R. Orto Botanico di Palermo. Marcellia, 1907, vol. vi, pp. 8-11.
- Elliott, E. A., and Morley, C.**—On the Hymenopterous Parasites of Coleoptera. Trans. Entom. Soc., 1907, pp. 7-75.
An invaluable compilation.
- Enderlein, G.**—The Scaly Winged Copeognatha. Spolia Zeylanica, 1906, vol. iv, pp. 39-122, pls. A-G, and 6 text figs.
- Green, E. E.**—Supplementary note on the Scaly Winged Copeognatha. Spolia Zeylanica, 1906, vol. iv, pp. 123-125.
- Jarvis, T. D.**—Insect Galls of Ontario. 37th (1906) Ann. Rpt. Entom. Soc. Ontario, 1907, pp. 56-72, pls. A-F.
- “It is a curious fact,” the author states, “that the insects which are of the most developed and specialised structure, produce the most complex galls. That is in the lower Orders, as Thysanura, the Orders formerly included in Neuroptera, Orthoptera, and other Orders, we find no gall-making habits; while in the Diptera, Hemiptera, and Hymenoptera, and to a slight extent in the Lepidoptera and Coleoptera we find the habit developed. This curious coincidence may possibly be explained thus—if, indeed, the lower and less specialised forms came into existence in an earlier age when a lower and now extinct type of vegetation flourished, ever produced forms with the habit of gall-making, these forms probably perished with the flora of that age, while the latter forms which now produce galls were evolved at a much later period when the flora resembled that of the present age.”
- Massalongo, C.**—Nuovi Zooecidii della Flora veronese. Marcellia, 1906, vol. v, pp. 152-158, 4 text figs.
- Mayr, G.**—Zwei Cynipiden. Marcellia, 1907, vol. vi, pp. 2-7, 1 fig.
- Moulton, D.**—A Contribution to our Knowledge of the Thysanoptera of California. U.S. Dept. Agric., Bur. of Entom., Tech. Ser. No. 12, pt. iii, 1907, pp. 1-68, pls. i-vi.
- Nalepa, A.**—Bemerkungun zu H. T. Gussow's Arbeit “*Eriophyes (Phytopus)* Knospengallen und Hexenbesen der Birke.” Marcellia, 1906, vol. v, pp. 159-161.
- Nalepa, A.**—Neue Gallmilben (29 Fortsetzung). Sitz. K. Ac. Wiss. Wien, 1907.
- Neumann, G.**—Description of two new species of African Ticks. Ann. Trop. Med. and Paras., 1907, vol. i, pp. 115-120, 4 text figs.
- Stegagno, G.**—A proposito dei parassiti-predatore. Marcellia, 1906, vol. v, pp. 167, 168.

Trotter, A.—*Cynips forlù*, n. sp. Descrizione ed istologia di una nuova galla d'Asia Minore. Marcellia, 1907, vol. vi, pp. 12-23, 5 figs.

IV.—AGRICULTURAL AND HORTICULTURAL.

- Adams, C. F.**—Some Insects of Orchard and other Fruits. Arkansas Agric. Exp. Stat., 1907, Bull. No. 92, pp. 1-17, 21 figs.
- Bailey, V.**—Directions for the Destruction of Wolves and Coyotes. U.S. Dept. Agric., Bur. of Biol. Sur., Circ. No. 55, 1907, pp. 1-6.
- Bioletti, E. T.**—Oidium or Powdery Mildew of the Vine. Agric. Exp. Stat., Berkeley, Cal., Bull. 186, 1907, pp. 315-350, 17 text figs.
- Bishop, F. C., and Jones, C. R.**—The Cotton Bollworm. U.S. Dept. Agric., Farmers' Bull. 290, 1907, pp. 1-32, 4 figs.
- Britton, W. E.**—Sixth Report of the State Entomologist of Connecticut. Rpt. Con. Agric. Exp. Stat. for 1906, 1907, pp. xii + 219-306, pls. i-xvi, 12 text figs.
- Butler, E. J.**—Some Diseases of Cereals caused by *Sclerospora graminicola*. Mem. Dept. Agric. India, Botan. Ser., 1907, vol. ii, no. i, pp. 1-24, pls. i-v.
- Chittenden, F. H.**—Some Insects Injurious to Truck Crops. U.S. Dept. Agric., Bur. of Entom., Bull. No. 66, pts. i and ii, 1907, pp. 1-20, 5 figs.
- Chittenden, F. H.**—The Colorado Potato Beetle. U.S. Dept. Agric., Bur. of Entom., Circ. No. 87, 1907, pp. 1-15, 6 figs.
- Chittenden, F. H.**—The Asparagus Miner. Notes on the Asparagus Beetles. U.S. Dept. Agric., Bur. of Entom., Bull. No. 66, pt. i, 1907, pp. 1-10, 2 figs.
- Collinge, Walter E.**—First Annual Report of the Honorary Consulting Zoologist. Journ. Land Agents' Soc., 1907, vol. vi, pp. 248-259, 3 figs.
- Flynn, C. W., Jr.**—The Boll Weevil. State Crop Pest. Comms. Louisiana, 1907, Circ. No. 11, pp. 1-19, figs. 1, 2.
- Forbes, S. A.**—Spraying Apple for the Plum-Curculio. Univ. of Illinois Agric. Exp. Stat., Bull. 108, 1906, pp. 265-286.
- Forbes, S. A.**—The Cottony Maple Scale in Illinois. Ibid, Bull. 112, 1907, pp. 343-360, pls. i-iii, 6 text figs.
- French, C.**—Fruit Flies. Journ. Dept. Agric. Victoria, 1907, vol. v, pp. 301-312, 1 plt.
- Girault, A. A.**—Hosts of Insect Egg-parasites in North and South America. Psyche, 1907, vol. xiv, pp. 27-39.
- Gossard, H. A., and Houser, J. S.**—The Hessian Fly. Ohio Agric. Exp. Stat.; Bull. 177, 1906, pp. 1-39.

- Gossard, H. A., and Houser, J. S.**—The Grapeberry Worm. (*Polychrosis viteana*). Ohio Agric. Exp. Stat., Circ. 63, 1906, pp. 1-16, 12 text figs.
- Hawaii Board of Agriculture and Forestry.**—Third Report of the Board of Commis. of Agric. and For. for 1906. Honolulu, 1907, pp. x + 212, 3 plts., 4 maps, and 7 text figs.
- Hinds, W. E.**—An Ant Enemy of the Cotton Boll Weevil. U.S. Dept. Agric., Bur. of Entom., 1907, Bull. No. 63, pt. iii, pp. 45-48, 1 fig.
- Hooker, W. A.**—The Tobacco Thrips, a new and destructive Enemy of Shade-grown Tobacco. U.S. Dept. Agric., Bur. of Entom., Bull. No. 65, 1907, pp. 1-24, plts. i, ii, 2 figs.
- Hopkins, A. D.**—The Locust Borer and methods for its control. U.S. Dept. Agric., Bur. of Entom., Circ. No. 83, 1907, pp. 1-8, 4 figs.
- Hopkins, A. D.**—Additional Data on the Locust Borer. *Ibid.*, Bull. No. 58, pt. iii, 1907, pp. 31-40.
- Houser, J. S.**—Spraying for the San Jose Scale. Ohio Agric. Exp. Stat.. Bull. 169, 1906, pp. 141-155, plts. i-vi.
- Howard, L. O.**—The Gipsy Moth and How to Control it. U.S. Dept. of Agric., Farmers' Bull. 275, 1907, pp. 7-22, 7 figs.
- Howard, L. O.**—The Present Condition of the Gipsy Moth in New Hampshire. New Hampshire Agric. Exp. Stat., 1907, Bull. 128, pp. 225-230, 3 figs.
- Jarvis, T. D.**—Two Insects affecting Red Clover Seed Production. 37th (1906) Ann. Rpt. Entom. Soc. Ontario, 1907, pp. 41-45.
Accounts of *Cecidomyia leguminicola* and various species of *Bombus*.
- Johnson, T.**—Some Injurious Fungi found in Ireland. Econ. Proc. Roy. Dublin Soc., 1907, vol. i, pp. 345-370, plts. xxxii-xxxv, and 5 text figs.
- Lefroy, H. M.**—The Important Insects injurious to Indian Agriculture. Mem. Dept. Agric. India, Entom. Ser., 1907, vol. i, No. 2, pp. v + 113-252, 80 figs.

This is a most useful synopsis, giving brief details of the more important insects injurious to Indian Agriculture. No such list exists at present, and this is published with a view to fixing definitely the nomenclature and status of such pests. In each case the reference to the original description is given, and notes on the distribution, life-history, food plants, status, larva, etc.

- Lefroy, H. M.**—The Indian Surface Caterpillars of the Genus *Agrotis*. Mem. Dept. Agric. India, Entom. Ser., 1907, vol. i, No. 3, pp. 253-274, plt. xiv.

Figures and descriptions of the following species are given: *Euxoa spinifera*, Hubn., *E. segetis*, Schiff., *Agrotis flammatra*, Schiff., and *A. ypsilon*, Rott. The life-history of the last mentioned species is given in detail.

- Lefroy, H. M.**—Surface Caterpillars. Agric. Journ. India, 1907, vol. ii, pp. 42-46, plt. vii.
- Lefroy, H. M.**—Insect Pests of Jute. Agric. Journ. of India, 1907, vol. ii, pp. 109-115, plt. x, 1 text fig.
- A well illustrated account of *Cosmophila sabulifera*, Guen., and some minor pests.
- Morgan, A. C.**—A Predatory Bug reported as an enemy of the Cotton Boll Weevil. U.S. Dept. Agric., Bur. of Entom., 1907, Bull. No. 63, pt. iv, pp. 49-54, 2 figs.
- Morgan, A. C.**—The Cotton Stalk-Borer. (*Ataxia crypta*, Say.) Ibid., Bull. No. 63, pt. vii, pp. 63-66, plt. iii.
- Morrill, A. W.**—The Mexican Conchuela in Western Texas in 1905. U.S. Dept. Agric., Bur. of Entom., Bull. No. 64, pt. i, 1907, pp. 1-14, plt. i, 2 figs.
- Morrill, A. W.**—The Strawberry Weevil in the South-Central States in 1905. Ibid., Bull. No. 63, pt. vi, pp. 59-62.
- Moulton, D.**—The Pear Thrips. (*Euthrips pyri*, Daniel.) U.S. Dept. Agric., Bur. of Entom., Bull. No. 68, pt. i, 1907, pp. 1-16, plts. i, ii, and 8 figs.
- Newell, W.**—Report upon the Work of the State Crop Pest Commission. State Crop Past Comms. Louisiana, 1907, Circ. No. 13, pp. 1-11.
- Newstead, R.**—The Weeviling of Maize in West Africa. Q. J. Inst. Comm. Res. Liverpool, 1907, vol. ii, pp. 27-31.
- Pierce, W. D.**—Notes on the Biology of Certain Weevils related to the Cotton Boll Weevil. U.S. Dept. Agric., Bur. of Entom., 1907, Bull. No. 63, pt. ii, pp. 39-44, plt. i.
- Pierce, W. D.**—Notes on the Economic Importance of Sowbugs. U.S. Dept. Agric., Bur. of Entom., Bull. No. 64, pt. ii, 1907, pp. 15-22, plt. ii.
- Pratt, F. C.**—Notes on the Pepper Weevil. (*Anthonomus aenestinctus*, Champ.). U.S. Dept. Agric., Bur. of Entom., 1907, Bull. No. 63, pt. v, pp. 55-58, plt. ii, 1 text fig.
- Quaintance, A. L.**—The Aphides affecting the Apple. U.S. Dept. Agric., Bur. of Entom., Circ. No. 81, 1907, pp. 1-10, 8 figs.
- Quaintance, A. L., and Shear, C. L.**—Insect and Fungous Enemies of the Grape East of the Rocky Mountains. Ibid., Farmers' Bull. 284, 1907, pp. 1-48, 35 figs.
- Sanders, J. G.**—The Terrapin Scale. U.S. Dept. Agric., Bur. of Entom., Circ. No. 88, 1907, pp. 1-4, 3 figs.
- Sanderson, E. D.**—The Brown-Tail Moth in New Hampshire. New Hampshire Agric. Exp. Stat., 1907, Bull. 128, pp. 211-220, 5 figs.
- Sanderson, E. D., and Others.**—Spraying the Apple Orchard. Ibid., Bull. 131, pp. 1-56, 36 figs.

- Sanderson, E. D.**—Hibernation and Development of the Cotton Boll Weevil. U.S. Dept. Agric., Bur. of Entom., 1907, Bull. No. 63, pt. i, pp. 1-38, 6 figs.
- Scott, W. M., and Quaintance, A. L.**—Spraying for Apple Diseases and the Codling Moth in the Ozarks. U.S. Dept. Agric., Farmers' Bull. 283, 1907, pp. 1-42, 7 figs.
- Shear, C. L., and Miles, G. F.**—The Control of Texas Root-Rot of Cotton. U.S. Dept. Agric., Bur. of Plant Indus., Bull. No. 102, pt. v, 1907, pp. 1-8, 1 fig.
- Sly, F. G.**—South African Locust Fungus. Agric. Journ. of India, 1907, vol. ii, pp. 208, 209.
- Pure cultures of *Mucor exitiosus*, Masee, have been tested on the Bombay locust (*Acridium succinctum*, Linn.), the black-spotted grasshopper (*A. aeruginosum*, Burm.), the North-West migratory locust (*A. peregrinum*, Oliv.), and the rice grasshopper (*Hieroglyphus furcifer*, Serv.). The experiments show that the method is too uncertain to be of any assistance in the field in dealing with these insects.
- Smith, R. E.**—Report of the Plant Pathologist to July 1, 1906. Agric. Exp. Stat., Sacramento, 1907, pp. 219-256, 12 figs.
- Smith, J. B., and Dickerson, E. L.**—The Cabbage and Onion Maggots. New Jersey Agr. Exp. Stat., 1907, Bull. 200, pp. 1-27, 13 figs.
- Somerville, Wm.**—An Insect on the Larch. Field, 1907, June 1, pp. 909. Thought to be *Argyresthia laevigatella*.
- Taylor, E. P.**—Report of the Field Entomologist. Colorado Agric. Exp. Stat., Bull. 119, 1907, pp. 1-16.
- Volck, W. H.**—The Californian Tussock-Moth. Calif. Univ. Agric. Exp. Stat., 1907, Bull. 183, pp. 191-214, 17 figs.
- Washburn, F. L.**—Eleventh Annual Report of the State Entomologist of Minnesota, for the year 1906. St. Anthony Park, Minn., 1906, pp. 1-87, 1 plt. and 64 figs.
- Webster, F. M.**—The Corn Leaf-Aphis and Corn Root-Aphis. Ibid., Circ. No. 86, pp. 1-13, 4 figs.
- Webster, F. M.**—The Grasshopper Problem and Alfalfa Culture. U.S. Dept. Agric., Bur. of Entom., Circ. No. 84, 1907, pp. 1-10, 8 figs.
- Willcocks, F. C.**—Insects Injurious to the Cotton plant in Egypt. Pt. i, Cairo, 1906, pp. 103, pls. i-iv.

V.—FORESTRY.

- Halstead, Byron D.**—Forest Trees of New Jersey. New Jersey Agric. Exp. Stat., Bull. 202, 1907, pp. 1-52, 2 figs.
- Hopkins, A. D.**—The White Pine Weevil. U.S. Dept. Agric., Bur. of Entom., Circ. No. 90, 1907, pp. 1-8, 6 figs.

- Kellogg, R. S., and Hale, H. M.**—Forest Products of the United States. 1905. U.S. Dept. Agric., For. Service, Bull. 74, 1907, pp. 1-69, 3 figs.

VI.—FISHERIES.

- Lebour, Marie V.**—The Mussel Beds of Northumberland. Rpt. Sci. Invest., 1906, Northumberland Sea Fisheries Comm., 1907, pp. 28-46, Maps i-vi, and 6 text figs.

The authoress gives a very full account of an investigation commenced in 1905. The various beds are described in detail, and various suggestions made for their improvement. A short account is also given of the enemies of the mussels.

- Meek, A.**—Trawling Experiments. Ibid., pp. 9-27.

Professor Meek gives a useful summary of the trawling experiments of the past year, together with numerous tables showing the food, sex, and maturity of examples of the fish; the migrations of flat fish; and the migrations of crabs.

VII.—MEDICINE.

- Looss, A.**—On some Parasites in the Museum of the School of Tropical Medicine, Liverpool. Ann. Trop. Med. and Paras., 1907, vol. i, pp. 123-154, plts. vii-ix.
- Newstead, R., Dutton, J. E., and Todd, J. L.**—Insects and other Arthropoda collected in the Congo Free State. Ann. Trop. Med. and Paras., 1907, vol. i, pp. 1-112, plts. i-vi, 22 text figs.
- Reed, T. E.**—The Sex Cycle of the Germ Plasm. Its relation to Sex Determination. N.Y. Med. Times, 1906 and 1907 (Reprint, pp. 1-40).
- Ross, E. H. and H. C.**—An Automatic Oiler for the destruction and prevention of Mosquito Larvae in Cesspools and other collections of Water. Ann. Trop. Med. and Paras., 1907, vol. i, pp. 163-167, plt. xi.
- Warren, Ernest.**—Note on the Larva of a Fly (*Sarcophaga* sp.) occurring in the Human Intestine. Ann. Natal Gov. Mus., 1907, vol. i, pp. 215-218.

VIII.—ANIMAL DISEASES.

- Bolton, B. M.**—The Bacteriolytic Power of the Blood Serum of Hogs. U.S. Dept. Agric., Bur. of An. Indus., Bull. No. 95, 1907, pp. 1-62, 4 figs.
- Hunter, W. D.**—Note on the occurrence of the North American Fever Tick on Sheep. U.S. Dept. Agric., Bur. of Entom., Circ. No. 91, 1907, pp. 1-3.

Records the finding of specimens of *Boophilus annulatus*, Say, on sheep, from Jackson Co., Texas.

Imms, A. D.—Report on a Disease of Bees in the Isle of Wight. Journ. Bd. Agric., 1907, vol. xiv, pp. 129-140, 4 figs.

Proceedings of a Conference of Federal and State Representatives to consider plans for the Eradication of the Cattle Tick. U.S. Dept. Agric., Bur. of An. Indus., Bull. No. 97, 1907, pp. 1-98.

Ransom, B. H.—Stomach Worms (*Haemonchus contortus*) in Sheep. U.S. Dept. Agric., Bur. of An. Indus., Circ. No. 102, 1907, pp. 1-7.

Woodruffe-Peacock, Rev. E. A.—Grouse Disease. Pp. ix + 103. Louth: J. W. Goulding and Son, 1907. Price 5/-.

This is a very rambling work, and we fear it leaves the question of grouse-disease very much where it found it. The author accepts "Pneumo-enteric" as "the true grouse disease," but as Mrs. Squeers thanked God she was no grammarian, so the Vicar of Cadney tells us "I am no bacteriologist," and his opinion on this matter rests only on naked eye inspection, and perhaps on a trained sense of smell.

Much of the book consists of extracts from the "Field" and other Journals devoted to sport, and this is all the more remarkable, as on p. 12 the author assures us that he has "never read any game literature." In fact this book is of little real value, there is no critical examination of the various alleged causes of the disease, and no first-hand complete account even of the symptoms. There is a great deal of loose dogmatism, and the sort of thing sportsmen enjoy writing and reading in the sporting journals. The author does not, in Dr. Johnson's phrase, "talk tightly," and although some of his remarks upon the management of moors seem reasonable, they have mostly been made before, and we fear that the only thing we can say in his favour is that he has added another to the sufficient large series of books which deal with grouse disease without advancing our knowledge of it.

France, N. E.—The History of Bee Disease Inspection in Winconsin. U.S. Dept. Agric., Bur. of Entom., Bull. No. 70, 1907, pp. 73-75.

Parker, F. A.—American Foul Brood on the Pacific Coast. *Ibid.*, pp. 57-73.

Phillips, E. F.—The Present Status of the Investigation of Bee Diseases. *Ibid.*, pp. 22-55.

An interesting and most useful paper.

Stewart, Chas.—Apiary Inspection in New York State. *Ibid.*, pp. 55-57.

White, G. F.—The Bacteriology of Bee Diseases. *Ibid.*, pp. 10-22.

The author briefly discusses the science of bacteriology as it is used in the study of bee diseases, and gives a summary of his work on these diseased conditions.

Newell, W.—A Simple plan of Eradicating the Cattle Tick by the Pasture Rotation Method. State Crop Pest Comms. Louisiana, Circ. No. 14, 1907, pp. 1-4.

Cave, T. W.—Veterinary Notes. Journ. S.-E. Agric. Coll. Wye, 1907, pp. 363-373.

The author gives a brief account of "struck" sheep experiments; the parasites of the fourth stomach of cattle and sheep; "gid" in lambs; and a case of anthrax in a cow which was undergoing the tuberculin test.

IX.—COMMERCIAL.

Castillo, L. e Vergara, Z.—Apuntes biológicos e industriales sobre la Ostra de Chile. Mininterio de Industria, 1907, pp. 1-59, 9 figs.

Pye, H.—Wheat and Wheat Breeding. Journ. Dept. Agric. Victoria, 1907, vol. v, pp. 439-448.

THE
JOURNAL OF ECONOMIC BIOLOGY.

ON THE BIONOMICS OF CERTAIN CALYPTRATE MUSCIDAE
AND THEIR ECONOMIC SIGNIFICANCE, WITH ESPECIAL
REFERENCE TO FLIES INHABITING HOUSES.¹

By

C. GORDON HEWITT, M.Sc.,

Lecturer in Economic Zoology in the University of Manchester.

No other group of Diptera, or in fact of insects, contains so great a number of species, and species individually important, which are directly or indirectly concerned in the welfare of man. Their economic relationships to man are as diverse as the habitats of their larvae, and whereas some species are the carriers of disease capable of more than decimating a population, others destroy the harbingers of famine and poverty. There is a tendency in studying creatures whose habits make them our enemies to lose sight of their near relatives waging war on our behalf, and thus our conception of the economic significance of a group is rendered one-sided, and we deny ourselves for the time any pleasure which might be derived from a contemplation of the item in the other pan of the scale. A study of the Calyprate *Muscidae* gives us both aspects of the economic question.

The Calyprate *Muscidae* are characterized by the presence of a squama at the base of the wing. This is the proximal lobe of the posterior margin of the wing attached to the side of the thorax, posterior to the wing-base and covering the halteres. In the Acalyprate *Muscidae* only two lobes instead of three are found at the base of the posterior margin of the wing. Three families of Diptera are included in the group *Muscidae Calypratae*, namely, the *Tachinidae*, the *Mus-*

¹This paper was read before the Association of Economic Biologists at the Imperial Institute, London, on July 4th, 1907.

cidae, and the *Anthomyiidae*, and it is my desire in this communication to make a few observations on some of the results of my study of these three families.

The first family, the *Tachinidae*, includes in its genera a large number of flies parasitic on Lepidoptera and other insects. This fact renders their bionomics of great economic importance, and except in the case of the silkworm, *Bombyx mori* (and other species of caterpillars cultivated for their silk), which is attacked by the Tachinid *Ugimyia sericaria*, Rond., causing the troublesome "Ugi" disease, they, together with the Ichneumons, are of great service to man in preventing the too excessive multiplication of the Lepidoptera. In cases where the lepidopterous larvae attack cultivated plants the utility of such parasites, which was probably not previously noticed, becomes appreciated by man.

The Magpie Moth, *Abraxas grossulariata*, Steph., which is responsible for so much damage to currant and gooseberry bushes, is attacked by a Tachinid of the genus *Exorista*, in all probability *E. agnata*, Rond. From 800 caterpillars from different localities in the neighbourhood of Manchester I obtained by dissection 53 larvae of this species, that is, more than 6 per cent. were parasitised—though I have known a greater percentage in previous years.¹ My investigation of this insect is not yet completed, as the assumption of a parasitic mode of life serves to enhance the difficulties which are experienced in studying the bionomics and life-histories, etc., of these Diptera.

The larva of *A. grossulariata* are about half-grown during the first half of May, and the infected individuals at this period are found to contain recently-hatched Tachinid larvae about 1.5 mm. in length; these larvae are already attached by their posterior stigmata to one of the lateral tracheal trunks of the host opposite to one of the stigmata of the latter, by means of which they breathe. In no case have I found more than a single parasite in one caterpillar; I have, however, obtained several of another species from the larva of the Emperor Moth, *Saturnia carpini*. The larva lies in the body cavity of the host, usually in the posterior half, enveloped in a yellow sheath, which is probably produced by the coagulation of the blood of the host by means of the secretion of the salivary glands, which are well developed in the young Tachinid larva; the sheath has part of the adjacent fat body incorporated in its substance. In this position feeding on the fat body of the host the larva undergoes two ecdyses, the cast larval

¹In the discussion which followed this paper, Mr. Walter E. Collinge, M.Sc. (Birmingham), stated that he had found about 25 per cent. of the larvae of *A. grossulariata* tachinised in a previous year.

skins remaining attached at the posterior end, where the parasite is permanently attached to the trachea of the host. When the larva is full grown, measuring about 8 mm. in length, it leaves its point of attachment and feeds for a short time on the interior of the host. The host at this time is generally full grown and ready to pupate, and now an infected, or, as I propose to call it, a Tachinised larva, can generally be recognized by the swelling caused by the size of the contained parasite. After feeding in this free state for a short time, often destroying part of the alimentary tract and emulsifying the metamorphosing tissues, the Tachinid bores its way through the body wall of the host, and either pupates in the partially spun cocoon of the latter or falls to the ground, in which case it works its way for a short distance below the surface of the soil before pupating. In the case of *A. grossulariata* I have never known a tachinised larva to pupate, the Tachina larva leaves the host before pupation, which in the case of a tachinised larva does not therefore take place. In some species, however, such as *S. carpini*, previously referred to, the host pupates before the larva emerges. The flies emerge about ten days later, and continue to emerge during June. I have not yet filled up the gap between the mature insects of June and July and the young larvae of the following year. *A. grossulariata* does not have a second brood in the year; it is a species which passes the winter as a hibernating larva, the larva being about half an inch long. In the following May, when the larva is about half grown, it contains a recently hatched Tachinid larva, which I believe tends to show that it has been quite recently infected. How then is this long period between July of one year and early May of the next filled up? I believe that the Tachinid, *E. agnata*, has a second brood in the year, and that this brood lives in a different species of lepidopterous larva from that parasitised by the first brood. The same species of Tachinid is able to parasitise different species of lepidopterous larva; for example, I have obtained the species which Tachinises *S. carpini* from the Buff Tip Moth, *Phalera bucephala*, and records of other observers exist,¹ consequently one may safely assume that the flies of *E. agnata* on becoming sexually mature, and failing to discover the species of lepidoptera previously tachinised, will deposit their eggs on the species most suitable. Pantel,² who has made a detailed study of a species of Tachinid, *Thrixion halidaynum*, Rond., which is para-

¹ See Girschner, E., Entom. Nachr. p. 177-186, where he gives a list of the hosts of fifteen species of European Tachinidae.

² Pantel, J. Le Thrizion Halicayanum Rond. Essai monographique sur les caracteres extérieurs, la Biologie et l'Anatomie d'une larve parasite du group des Tachinaires (Louvain) 290 p. 6 pl. 1898.

sitic on a Phasmid, *Leptynia hispanica*, Bol., having a period of about eight or nine months to fill in the life-history of the parasite, considered that it might choose not only another species of Phasmid, but an insect host of a different order. I have no evidence yet as to how the winter is passed. Sasaki¹ found that *Ugimyia sericaria* passed the winter in the pupal state. The problem of the second brood, and possibly of a third, still remains to be solved, and the fact that so far I have not succeeded in keeping any of the flies of the first brood long enough in captivity to become sexually mature, however roomy may be their cage, renders the experimental method of obtaining evidence on the question most difficult.

Theobald,² referring to the Brown Tail Moth (*Porthesia chrysoorrhoea*, Linn.), says: "This moth, which was so abundant in East Kent in 1900 and 1901, has only once been recorded since, until this year, when Mr. Wright brought me a winter tent sent him from near Hythe, and another was received from near Ashford. The rapidity with which it died out was partly due to some parasitic flies (*Thelymorpha vertiginosa*, Fl.) which I bred out in great numbers in 1901." This shows that a Tachinid may naturally produce apparent results in the diminution of a noxious insect, although of course other as yet unknown causes may assist. The larvae of lepidoptera, however, are protected to a considerable extent by their method of growth by moulting from the attacks of Tachinidae. The eggs of the Tachinid which have been deposited on the body of the caterpillar are often cast with the skin of the latter, when it undergoes ecdysis, before the Tachinid larvae have hatched and worked their way into the caterpillar's body. Howard³ mentions a case in which 226 moths and only 4 Tachinids were obtained from 235 larvae of the Gipsy Moth (*Ocneria dispar*, L.), upon each of which there had been from 1 to 33 Tachinid eggs. In another case 252 larvae bearing Tachinid eggs were reared, and not a single fly emerged.

From these few facts it will be seen that the *Tachinidae* are not only most important in Nature's economy, but also when certain plants become objects of cultivation they are valuable allies of man. On the other hand, where the lepidopterous larva is cultivated, as in the

¹ Sasaki, C. On the Life-History of *Ugimyia sericaria* Rond. Journ. Coll. Science, Tokyo, vol. i, p. 1-46, pls. i-vi, 1887.

² Theobald, F. V. "Report on the Economic Zoology for the year ending April 1st, 1907," South Eastern Agricultural College, Wye, 152 pp., 20 figs., 29 pls.

³ Howard, L. O. A Study in Insect Parasitism. A consideration of the parasites of the White Marked Tussock Moth, with an account of their habits and interrelations, and with descriptions of new species. U.S. Dept. Agric., Div. of Entomology, Tech. Ser. No. 5, 1897, 57 pp., 24 figs. (page 51).

isolated example of the silkworm, the fly, or to be correct, man has changed sides.

The *Muscidae* form the second family of the Calyptrate *Muscidae*, and include those species of flies with which most people are acquainted. In this family the majority of the larvae live in decaying animal or vegetable matter. Many species, however, are parasitic, and although the economic value of these to man may not be very great in this country, in other countries it may be so; for example, the fly *Idia lunata*, Meig., is of great service in destroying the locust, *Schistocerca peregrina*, in Algeria.

The great economic importance of those African allies of our English Stomoxys, the Tse-tse flies, *Glossina palpalis*, Rob-Desv., and *G. morsitans*, Westw., needs no reference on my part.

The member of this family of which I have been making a detailed study during the past two years is that insect with which most people are acquainted, *Musca domestica*, L. Although it is at certain times of the year very constant in its attendance on man, he had apparently not troubled himself very seriously with a study of his ubiquitous companion. It was not until it was recognized that this insect was something more than merely troublesome on account of its numbers and attentions, that it was capable of acting as a disseminator of such infectious diseases as anthrax, cholera and typhoid, etc., that any serious notice was taken of it. In America, Howard,¹ following Packard (1875), has investigated the life-history and habits of this insect. In this country it has not been studied, except in a very popular manner, and I have already found that in certain details, e.g., in the rate of development, it differs from the American forms. As the results of my studies are being published elsewhere,² I will not do more than refer to one or two bionomic points of a general character.

M. domestica is not the sole species of Calyptrate Muscid commonly found in houses, although it is usually the most abundant. This fact should be borne in mind in using the term "house-fly," which, as popularly used, and in fact as generally used, includes several species, though originally the name had, and still should have, a specific meaning. Another insect, *Homalomyia canicularis*, L., often called the small house-fly, occurs in houses. This insect belongs to the

¹ Howard, L. O. "House Flies" ("The Principal Household Insects of the United States," by L. O. Howard and C. L. Marlatt). United States Department of Agriculture, Washington. Division of Entomology, Bull. No. 4, N.S. revised ed., p. 43-47, and figs. and Circular, No. 35, 2nd Series, p. 1-8 and figs., 1898.

² Hewitt, C. G. "The Structure, Development, and Bionomics of the House-Fly, *Musca domestica*, Linn., Part I—The Anatomy of the Fly." Quart. Journ. Micro. Sci., 1907, vol. 51, pp. 395-448, pls. 22-26,

next family of Calyptrate *Muscidae*, the *Anthomyidae*; it is smaller than *M. domestica*, and its abdomen is more slender and tapering. So far as the dissemination of disease by flies is concerned, the species of fly may seem immaterial, as some of my medical friends have remarked to me, but this is not so in all cases. Different species have different habits, and the habits of some are much more conducive to the dissemination of pathogenic bacteria than those of others. Further, the difference of habit necessitates the adoption of different eradivative and preventive methods. For instance, let us consider these two species, *M. domestica* and *H. canicularis*, which occur most commonly in houses. The former breeds chiefly in horse manure, and I find that if it can have access to that it will not lay its eggs on other matter, although the larvae will feed on various other waste food materials. *H. canicularis* breeds in a number of decaying substances. Taschenberg¹ mentions its occurrence in "Abtritt"; I find that it breeds freely in human excrement, and have found in old-fashioned privies living masses of the larvae of this insect. It is manifest that if we desire their eradication these two species must be attacked in different ways. To get rid of *M. domestica* there should be no exposed heaps of horse manure. Howard (*l.c.*) recommends, as the result of experiments made in 1898 in the stables of the U.S. Department of Agriculture, the treatment of the manure, which is to be kept in a closet, with chloride of lime. If the manure be regularly covered every few days or sprinkled with such a substance every time fresh manure is thrown into the closed chamber, any larvae which may have been seen hatched out will be killed, and flies will be prevented from depositing their eggs.

The electrification of street cars and the introduction of horseless vehicles is a step towards the diminution of the numbers of *M. domestica*, but I would go further, and suggest that legislative powers should be sought whereby such a body as the Local Government Board might compel the proper treatment of manure heaps. It is useless to expect a diminution of the numbers of this household pest, and potentially the most dangerous one we have, when there are stables dotted over all our towns and cities with exposed manure heaps, providing flies to carry infection, if there chance to be any, to fresh spots. London, for example, has over 10,000 licensed cabs, I have not statistics of the number of mews. With such means of supply we cannot hope for any appreciable decrease in the numbers of this insect until such proper care is taken. In country districts we cannot expect, under present conditions, any decrease in the numbers of flies, but in towns such a

¹ Taschenberg, E. L. *Praktische Insektenkunde*, 1880. Vol. iv, pp. 133-134.

decrease can be brought about, and it is not so much in the country as in the towns, where less hygienic conditions prevail, that the danger from flies becomes so great.

Turning to the other insect, *H. canicularis*, which at present seems to me to be quite as guilty as *M. domestica* in the dissemination of infectious disease. The method to be adopted to bring about its decrease would be the universal adoption of the water-closet system, and also the proper disposal of kitchen refuse. By this means we should abolish its chief breeding places. *H. canicularis* is a very common inhabitant of houses in this country; in many houses which I have examined I find it occurs in greater numbers than *M. domestica* in the earlier part of the season. Though I have not yet investigated the problem so fully as I intend to do, so far I have found that *H. canicularis* occurs more commonly in privies than *M. domestica*, which one would expect, as the female flies lay their eggs in the contents of such places, whereas the females of *M. domestica* are much more common about stable refuse. This year I am making a census by means of fly-papers of flies from different localities and in different conditions; from such a collection it will be possible to obtain more precise information as to the different species of flies inhabiting houses in different districts, the proportion in which they occur, and where certain species predominate. In a collection which Howard¹ made of dipterous insects occurring in kitchens and pantries in America, out of 23,087 he obtained 98.8 per cent. *M. domestica*, and .35 per cent. were *H. canicularis*. I believe, however, that in England the proportion of *H. canicularis* will be much greater than that found in America, especially if collections are made in privies and similar places.

It is the flies which frequent both privies and houses which must be destroyed, as well as those found only in houses. There is a greater danger in the dissemination of pathogenic bacteria from a privy than from a house, unless, of course, exceptionally unsanitary conditions prevail in the latter, consequently there is a greater danger from flies frequenting such places than from those which do not. A full discussion of this question, which has already been referred to by Howard (*l.c.*), Austen,² Shipley,³ and very completely by Nuttall,⁴ will be

¹ Howard, L. O. A contribution to the Study of the Fauna of Human Excrement, with especial reference to the spread of Typhoid Fever by Flies. Proc. Wash. Acad. Sci., 1900, vol. ii, pp. 541-604, 2 pls.

² Austen, E. E. The House-fly and certain allied species as disseminators of Enteric Fever among Troops in the Field. Journ. Roy. Army Med. Corps, 1904, 16 pp., 2 pl.

³ Shipley, A. E. The Danger of Flies. Science Progress, April, 1907.

⁴ Nuttall, G. H. F. On the Role of Insects, Arachnids and Myriapods as carriers in the spread of bacterial and parasitic diseases in man and animals. A critical and historical study. John Hopkins' Hospital Reports, 1899, vol. viii, pp. 1-154, 3 pls.

reserved until my investigations are complete. These facts concerning the bionomics of the flies under discussion are emphasized here and now in the hopes that some steps might be taken by medical officers of health and others in authority to bring about these necessary reforms in the present unsanitary and dangerous conditions which still prevail. This short account may seem somewhat pessimistic; on the contrary, I look forward with hope that many of these nuisances will be cleared away; horse-drawn vehicles are gradually being supplanted in our cities and towns, with a consequent decrease in the number of breeding places of *M. domestica*; municipal authorities are abolishing the old style privy and the construction of hygienic water-closets, thus doing away with another evil, though probably unknown to them, and if regulations were made with respect to the proper treatment or frequent removal of stable refuse, we should have this source of disease dissemination within harmless bounds, and more peaceful, healthy conditions reigning in the homes of our people.

We must not lose sight of the importance of many of the *Muscidae* which are sarcophagous, such as *Calliphora vomitoria* and its allies, which act as scavengers. The larvae of these Muscids are responsible for the distribution of the carcasses of dead animals which might otherwise prove a source of danger.

In the *Anthomyidae*, the third family of the Calyptrate *Muscidae*, there are several species whose larval habits render them of considerable economic importance. Many of the larvae are phytophagous, and in those cases in which their food plants are cultivated they sometimes become a serious pest. The economic relations of *H. canicularis*, which is a member of this family, have already been referred to. The Cabbage Root Maggot, *Phorbia (Anthomyia) brassicae*, Bouché, does great damage to cabbage crops in this and other countries. In America, Slingerland¹ has studied the habits of this insect, and suggested the best remedial measures, such as tarred paper discs round the bases of the stems of the young plants and carbon bisulphide. An ally of the last insect, the Root Maggot, *Anthomyia radicum*, Meigen, is also a pest on certain of the *Cruciferae*, such as *Raphanus* and *Brassica*. I have recently studied the life-history of this species,² and find that the female is attracted to, and deposits her eggs very freely upon, horse manure in which the larvae develop in a comparatively short

¹ Slingerland, M. V. The Cabbage Root Maggot, with notes on the Onion Maggot and Allied Insects. Bull. 78, Cornell Univ. Agri. Expt. Sta., Ithaca, N.Y., 1894, 97 pp., 18 figs.

² Hewitt, C. G. "On the Life-history of the Root Maggot, *Anthomyia radicum*, Meigen." Journ. Econ. Biol., 1907, vol. ii, pp. 56-63, pl. vi.

time. This is a point of considerable importance. Miss Ormerod believed that *P. brassicae* fed on the manure which was used in cultivating the cabbage, although Slingerland believes that the occurrence of the insect in very great numbers where stable manure is used is due to the fact that it attracts the female flies, "and not because the manure furnishes a further supply of food for the maggots." I have not studied *P. brassicae*, but I have no hesitation in concluding from my study of *A. radicum* that in the case of this insect the presence of stable manure in the soil would not only attract the female flies, which in itself is an evil, but would also greatly facilitate the production of larger numbers of root-devouring larvae. Further, in supplying to the young plants stable manure which had been exposed in the ordinary way, there would be a great probability of its containing not only the eggs but the larvae of the pest.¹

Some of the *Anthomyidae* are beneficial in that, owing to a change of habit, they feed on such pests as the locusts. The eggs of the migratory locust, *Schistocerca peregrina*, not only suffer from the attacks of the Muscid, *Idia lunata*, as previously mentioned, but also from the attacks of *Anthomyia cana*. In his investigations on the Rocky Mountain locust, *Caloptenus spretus*, in 1877, Riley showed that the *Anthomyia Phorbia fusciceps*, Zett., which he then considered a variety of *A. radicum*, was of great service in destroying the eggs of the locust, in fact it was estimated that about 15 per cent. of the locust eggs in Missouri, Kansas, and Nebraska were destroyed by the larvae of this insect, which Slingerland named the Fringed Anthomyian, on account of the distinguishing character of the bristles on the inside of the hind tibiae of the males. *P. fusciceps* is of considerable interest, as it also assumes the role of a pest. It attacks the onion, and also, as Riley discovered in 1869, the young seed-corn, on the occasion of which discovery he called it *A. zae*.

From these facts it will be seen that not only in the same family

¹ Since this paper was written, Mr. F. V. Theobald has given me his Report on the Economic Zoology for the year ending April 1st, 1907, of the South Eastern Agricultural College, Wye, in which (pages 122-123) I find some evidence which tends to show that the presence of manure is beneficial to the larvae of *P. brassicae*, as Miss Ormerod believed, and as I have shown to be the case with *A. radicum*. The report referring to the occurrence of *P. brassicae* says:—"Writing on the 23th the correspondent says: 'It is a strange fact that although I grew the plants in the same field and under similar conditions last season, I have one piece about ten acres very good, and the larger piece of about fifteen acres is equally bad. They are two different kinds of swedes, the fifteen-acre lot is purple and the other green-top. But why such a difference? The fifteen acres was heavily manured last winter, the other field had grown a crop of mangel seed after being manured, and both lots of plants appeared quite healthy when planted out.'" (The italics are mine.) This, I think, clearly shows the effect of manure on the presence of the larvae of *P. brassicae*.

do we meet with noxious and beneficial insects, but even the same insect may on one occasion be beneficial and on another noxious. One cannot be content therefore with a study of the life-histories only of these insects, but in addition to this a careful investigation into the bionomics of the same must be made in order that a perfect conception of their economic importance may be obtained, and that this knowledge may be correctly applied in every case.

NOTES ON TICKS.

By

CECIL WARBURTON, M.A., F.Z.S.,

Christ's College, Cambridge.

WITH PLATE VII.

THE study of tick-conveyed diseases is, of course, a pathological matter. But the pathologists naturally look to the economic zoologists to assist them in the systematic and biological study of the ticks themselves, and it is to those who may be called upon to take up such a study that the following notes may be of interest. They are founded upon the examination of a large number of ticks from all parts of the world during the last two years.

In the first place I confess myself dissatisfied with the accepted classification of ticks; that of Neumann. It is this:—

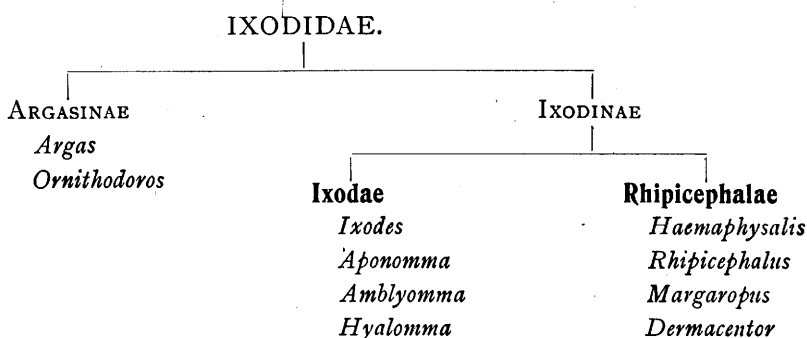

I consider the *Argasinae*, the *Ixodinae* deserving of family rank, and I do not agree with the merging of *Boophilus* with *Rhipicephalus*. In various other points the above arrangement appears to me unsatisfactory, and especially in not giving due weight to the differences which exist between *Ixodes* and the other genera of the *Ixodinae*. Canestrini separated it under the title of *Poliopli*, but his other groups (*Tetraopli* and *Anopli*), founded upon acquaintance with too restricted a fauna, cannot be accepted.

I propose the following Classification:—

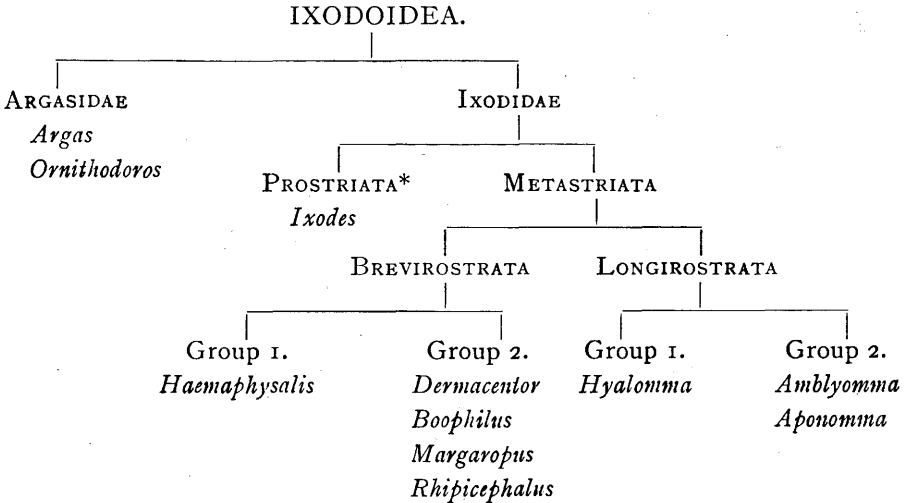

Of the *Argasidae* I have no more to say. The following notes refer entirely to the *Ixodidae* (*Ixodinae* of Neumann).

A word or two may be said about each genus in turn.

Ixodes.—In addition to the characteristic anal groove, which distinguishes it from all the other genera, note.

- (1) The long palps with the second joint narrow at the base so that there is a space between it and the hypostome.
- (2) The absence of festoons.
- (3) The large proportion of the body of the female posterior to the legs.

Brevirostrata, Group 1.

Haemaphysalis.—The chief characteristic is the rostrum or capitulum, which has a transversely rectangular base, and conical palps projecting much beyond it laterally. They are also distinguished from the other *Brevirostrata* by the absence of eyes. Often slightly chitinised, and the sexual differences are not great. Not ornate. No anal plates. Dorsal projection on 1st trochanter.

Group 2.

All have eyes.

Dermacentor is not so closely allied to the others as they to each other. It sometimes approaches *Haemaphysalis* in its rostrum, which generally has a sub-rectangular base, and sometimes the palps, which are usually massive, project laterally. The male is recognizable at once by the large fourth coxae. Ticks of this genus are generally ornate.

* In reference to the anal groove surrounding the anus in front.

Boophilus.—Rostrum with hexagonal base and very short ridged palps—shorter than the hypostome. Scutum hairy and striate—not punctate; elongate in female. Peritremes circular. Four sub-equal anal plates in male.

These characteristics seem to separate it clearly from *Rhipicephalus*, but whether the genus contains several species, or one species with several varieties is another question. I am inclined to think *B. annulatus*, *B. decoloratus*, and *B. australis* specifically distinct.

Margaropus.—Contains only a single species (from the horse, S. Africa), of which the female is intermediate between *Boophilus* and *Rhipicephalus*, while the male is entirely aberrant.

Rhipicephalus is a large and difficult genus, with many closely allied species. The palps are longer than in *Boophilus*, and not ridged. The scutum is punctate and very rarely ornate. There are normally four anal plates in the male, but the externals are always smaller, and may be absent. Peritremes, comma-shaped.

Longirostrata. Group 1.

Hyalomma.—Remarkably poor in species. Practically only one of economic interest. *H. aegyptium*.—Extremely variable in size and coloration. First three joints of palp sub-equal. Male, two posterior chitinous points in addition to the four anal plates.

Group 2.

Amblyomma and *Aponomma*.—Long palps, especially second joint. Generally ornate, with white, yellow, or metallic green markings. No anal plates.

Amblyomma.—Eyes.

Aponomma.—No eyes. Of no economic importance, usually found on reptiles.

DETERMINATION OF GENERA.

Of course, after a little experience, not only the genera, but also the species of the better known forms is recognized at a glance, but a few hints will probably be useful to those who have had little practice in identifying mites. In dealing with a miscellaneous collection it is best to distribute them into genera, and consider the species later, having regard to the forms likely to occur in the country of their origin. Males and slightly distended females should be selected for examination if possible.

The rostrum or capitulum and scutum are generally sufficient to indicate the genus, and these should be examined first, the conclusion being verified by reference to other structures. It is soon seen that there is a long type and a short type of rostrum.

If the rostrum is long, the genus is either *Ixodes*, *Hyalomma*, *Amblyomma*, or *Aponomma*.

If the palps are narrow at the base, leaving a gap between them and the hypostome, it is probably *Ixodes*. Verify by looking for the anal groove in front of the anus, the absence of eyes and festoons, and the circular or oval peritremes.

Palps of fairly uniform width throughout indicate one of the other genera.

If there is no great difference in the length of the palpal joints, and spherical eyes are present, it is probably *Hyalomma*. If a male, it may be determined immediately by the four anal plates and two additional posterior chitinous points.

If the second palpal joint is much the longest, it is either *Amblyomma* or *Aponomma*, the first having eyes, the second not. Moreover, the tick will probably be ornate, and an ornate long rostrum tick from a domestic animal is sure to be *Amblyomma*.

If the rostrum is of the short type, its shape leaves little doubt of the genus.

If the width across the base of the palps is considerably greater than that of the transversely rectangular rostral base, the genus is *Haemaphysalis*. Verify by the absence of eyes.

Dermacentor may have a somewhat rectangular rostral base, and more or less bulging palps, but eyes are present, and the ticks are generally ornate. If a male, note the fourth coxae, much longer than the others.

In *Rhipicephalus* and *Boophilus* the rostral base is hexagonal, being pointed laterally. Distinguish by the extremely short ridged palps and circular peritremes in *Boophilus*, and the moderate unridged palps and comma-shaped peritremes, of *Rhipicephalus*.

The accompanying diagrammatic figures are intended to show at a glance the chief characteristics of those genera which are economically important.

DIAGNOSIS OF SPECIES.

A great many of the early descriptions of species are quite useless, because it was impossible to know what particular points required to be noticed until a large number of forms had been studied. Even of the more recent diagnoses a large number are unsatisfactory for two reasons; in the first place the variability, both in size and in the accentuation of their particular characteristics, especially in the males, has been underestimated, and this has often led to the establishment of two or more species out of a single one.

In the second place there is no uniformity of plan in diagnoses, and points noted in the description of one species of a genus are not mentioned in the description of an allied species, so that comparison is impossible.

(1) *Variability*.—The examination of a great many ticks from all parts of the world has convinced me that they present a phenomenon which has been noticed in other Arthropoda, and that there are at least in many species what have been called "high males" and "low males." One frequently finds in the same consignment of ticks, small, poorly characterised males, and also others not only much larger, but with their characteristic points greatly emphasized. The extremes of series would certainly be taken for different species, but numerous intermediate forms connect them. For example, I have received from India a considerable number of ticks, which are no doubt Neumann's *Rhipicephalus haemaphysaloides*. The "low males" agree sufficiently well with his diagnosis, but the "high males" are half as large again, have the anal plates more hooked, and have the median festoon produced into a distinct caudal appendage, which this species ought not to have. Indeed the two adjoining festoons are also prominent.

Investigation of this point is required, and it would be a useful research to measure and draw a number of male ticks of different species at intervals after attaining maturity with a view to noting subsequent changes. In most cases we are quite ignorant of the length of life of the male ticks, but it is probably considerable. Some other Acarina are certainly capable of decided growth after attaining maturity, and I have noticed this phenomenon in the *Oribatidae*.

(2) *Uniformity of diagnosis*.—In most diagnoses important points are left unnoted, and many characteristics not at all specific are inserted. In *Rhipicephalus*, for instance, it is unnecessary to state that the sexual orifice is between the second coxae. If it is elsewhere the matter should be noted. But the most aggravating thing is to find that one species has the eyes pale and the peritreme white, but the palps not mentioned, while the next has such and such peculiarities of the palps, but nothing is said of the eyes or peritremes.

It would seem a simple matter to give a list of points which should be mentioned in each diagnosis, but this is not so, as it would differ in the case of each genus, and this makes it too complicated a matter to enter upon in the present paper.

For the purposes of the economic zoologist the field is very much reduced, as a large proportion of the described ticks are never found on domesticated animals, and several species which occur only rarely are hardly likely to be of economic importance. Out of many hun-

dreds of ticks collected from domesticated animals in India (horses, cattle, sheep, goats, dogs, camels), practically only four species were represented. This is perhaps an extreme case, but the species of *Ixodidae* (*sensu restricto*) which occur in any considerable numbers on these animals in any part of the world so far investigated scarcely amount to twenty-five.

It may be useful to give in conclusion a list of the principal species with notes on their distribution. Such a list will at all events indicate what species may be expected in collections from domestic animals in different localities.

<i>Ixodes ricinus.</i>	Europe and N. America. On all domestic animals. <i>I. ricinus</i> suspected of conveying canine piroplasmosis.
<i>Ixodes hexagonus.</i>	
<i>Haemaphysalis punctata.</i>	Europe, Africa and Asia. Chiefly on sheep.
" <i>flava.</i>	Japan. All domestic animals.
" <i>leachi.</i>	Africa. On the dog, conveying canine piroplasmosis.
" <i>bispinosa.</i>	India (especially Bombay). On cattle.
<i>Dermacentor reticulatus.</i>	Europe and Asia. On all domestic animals.
" <i>electus.</i>	The common American dog tick.
" <i>nitens.</i>	W. Indies. On the horse.
<i>Boophilus.</i>	Cosmopolitan in some form. Found on all domestic animals and conveying "red-water."
<i>Margaropus.</i>	S. Africa. On the horse.
<i>Rhipicephalus sanguineus.</i>	Cosmopolitan. On all domestic animals. Conveys canine piroplasmosis.
" <i>bursa.</i>	S. Europe and Africa. On all domestic animals. Conveys "carceag" to sheep.
" <i>simus.</i>	Africa. On all domestic animals.
" <i>evertsi.</i>	The "red-tick." S. and E. Africa. On all domestic animals.
" <i>capensis.</i>	S. Africa. On cattle.
" <i>appendiculatus.</i>	The Cape. On cattle, conveying "Rhodesian fever."
<i>Hyalomma aegyptium.</i>	Europe, Africa and Asia. On all domestic animals.
<i>Amblyomma americanum.</i>	N. America. On cattle.
" <i>cajenense.</i> }	S. America. On dog.
" <i>striatum.</i> }	
" <i>hebraeum.</i>	The "bont tick" of S. Africa, conveying "heart water."

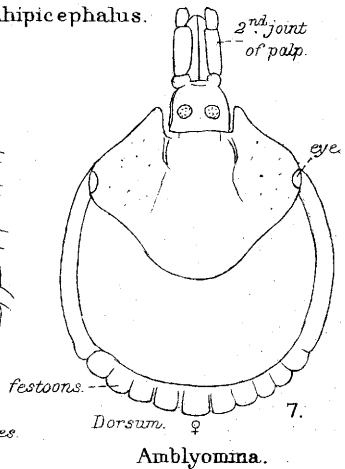
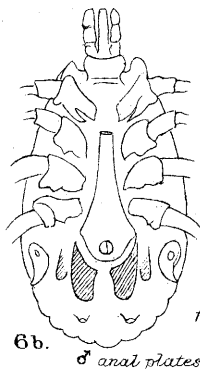
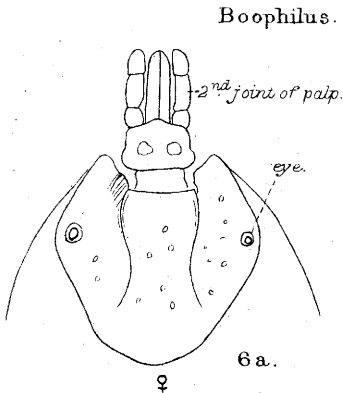
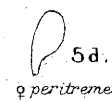
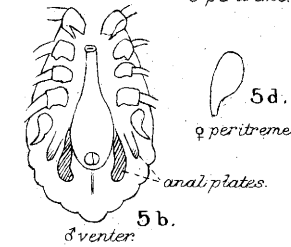
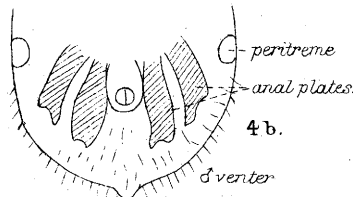
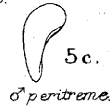
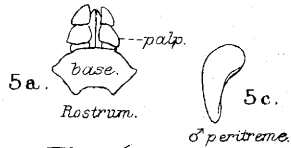
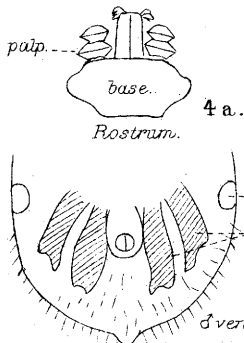
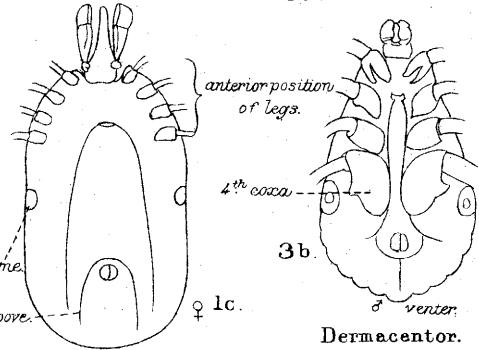
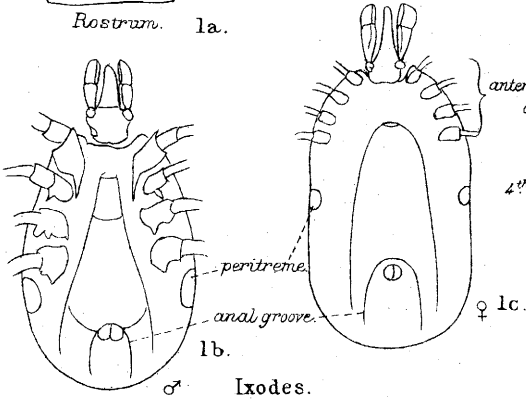
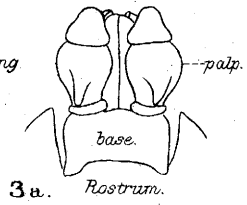
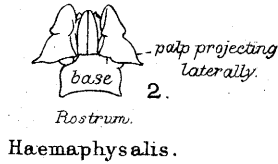
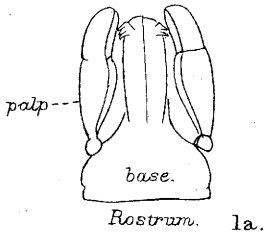

Amblyomma variegatum. Africa. On cattle and sheep. I am not convinced that this is anything but a variety of *A. hebraeum*, as I can find no satisfactory difference except the colour markings, which are variable.

EXPLANATION OF PLATE VII,

Illustrating Mr. Cecil Warburton's paper on Ticks.

Fig. 1a.— <i>Ixodes</i> .	Rostrum.
„ 1b.— „	Ventral side of male.
„ 1c.— „	Ventral side of female.
„ 2.— <i>Haemaphysalis</i> .	Rostrum.
„ 3a.— <i>Dermacentor</i> .	Rostrum.
„ 3b.— „	Ventral side of male.
„ 4a.— <i>Boophilus</i> .	Rostrum.
„ 4b.— „	Part of ventral side of male.
„ 5a.— <i>Rhipicephalus</i> .	Rostrum.
„ 5b.— „	Ventral side of male.
„ 5c.— „	Peritreme of male.
„ 5d.— „	Peritreme of female.
„ 6a.— <i>Hyalomma</i> .	Head of female.
„ 6b.— „	Ventral side of male.
„ 7.— <i>Amblyomma</i> .	Dorsal side of female.

THE APPLICATION OF ECONOMIC BIOLOGY TO AGRICULTURE.¹

By

WALTER E. COLLINGE, M.Sc., F.E.S.,

Special Lecturer on Economic Zoology in the University of Birmingham.

DURING the past few years the subject of Agriculture has loomed rather prominently in the public eye, and innumerable suggestions have been made—some good, some bad—in order to resuscitate this, the oldest of all callings. Amongst these various suggestions is that of the application of the results of modern science to everyday agriculture, and it is one particular side of this application that I venture to bring before you this afternoon, viz., the application of Economic Biology.

Science and Agriculture.—The subject of Agriculture is one of such immensity that no one science can lay claim to be the basis of such study and practice; biology, chemistry, geology, physics, and many other sciences all contribute their quota to the foundation upon which the Art or Science of Agriculture is founded; but if there is one science more than another from the application of which the agriculturist is likely to benefit, it is that of biology.

Hitherto in this country the contributions of the biologist to agriculture have been comparatively few, indeed the research and applied side have been mainly of a chemical nature. It is not my purpose, and far from my intention, to underrate the value of such work. Did any doubt linger in the mind of any intelligent man or woman, he or she has but to turn to the justly famous Rothamsted Memoirs, or that admirable and lucid summary by Mr. A. D. Hall, to at once dispel any such doubts, and to realize the importance and far-reaching bearing of such work. But whilst not wishing to underrate the value of the contributions of the chemist, the geologist, the physicist, etc., I do wish to bring before all thinking agriculturists the paramount importance of what I might term applied biology, and the vast possibilities it opens out; for be it remembered the agricul-

¹ The substance of this paper was delivered as a lecture in the Great Hall of University College, Bristol, on October 17th, 1907.

tourist is primarily concerned in the raising of plants and animals of the highest quality and the greatest quantity on the most economic basis, and all investigations which contribute in any way to the elucidation of the problems bound up in these tasks must confer a great boon upon the country at large.

In this country, in the past, biological research has been mainly of a systematic or morphological nature, and whilst such knowledge must ever be the basis for further work, biologists have, with few exceptions, been content to regard the means as an end, instead of a foundation upon which to build up a science of Economic Biology. As Professor Miall¹ has very aptly stated, "Morphology is very well; it may be exact; it may prevent or expose serious errors. But morphology is not an end in itself. . . . Surely our chief reason for studying animals [and plants] ought to be that we would know more of life."

I might, justly, I think, liken the biologist of the past to a man well versed in anatomy, physiology, clinics and therapeutics, who refused or failed to apply his knowledge to the alleviation of human pain or suffering.

We have grown, I fear, just a little too fond of talking of "pure science," and of praising the "investigator of science for science's sake"—whatever that may mean—rather than admit that in our shortsightedness we have failed to see the application of this or that result, or that this or that investigator has lacked the capacity to apply the results to everyday life. "Knowledge alone," states Helmholtz, "is not the destiny of man upon earth, knowledge must play its part in life."

Far be it from me to advocate that all biological work should be measured by the value of its immediate application. "A scientific research is a search after truth, and it is only after the discovery that the question of applicability can be usefully considered," (Moissan), but there is a certain school of biologists who regard any work which can at all be applied as something very inferior to the enumeration of the bones of some animal's skull, or a technical description of a new species. Such work has its place, but I certainly think that equal praise and reward are due to the man who can seize hold of the results of his or others' researches, and weave them into the daily life of a nation or community for their benefit.

That Agriculture is largely dependent upon science all will admit, but the workers are few. Of recent years we have seen a great impetus

¹Rpt. Brit. Assoc. Toronto Meeting, 1897, 1898, p. 667.

given to the study of disease due to parasites and diseases carried by parasites and insects. No sane man or woman doubts for one moment the value of the work of such men as Ross, Manson, Boyce, Shipley, Nuttall, and a host of other workers, and it is for the benefit of the agriculturist that I wish to see a similar class of men arise. In short, I wish to see done for agriculture what these men have done for medicine and humanity in general.

In the past the medical man, the veterinary surgeon, the breeder, the horticulturist, and the forester, have each done something towards extending our knowledge, but without a special training in plant and animal biology, and with other more pressing duties ever on their hands, the progress has been slow, and not unfrequently doubtful.

The Teaching of Economic Biology.—As regards the teaching of Economic Biology in this country, so far it has received but scant attention. In not a few cases it has merely meant the addition of another class or course of lectures in the already established departments of Zoology and Botany. The futility and fallacy of such procedure is surely apparent, for whilst, as I have already stated, morphology, embryology, and physiology must ever be the basis upon which all sound knowledge of Economic Biology is built, the staffs in these departments are already fully occupied—often too much so—with courses treating of their subjects from these standpoints only. Is it not unfair to expect a sudden specialisation on the part of these teachers, in parasitism, economic entomology, helminthology, mycology, etc.?

Mr. A. C. True¹ has given expression to the same idea as regards other sciences. "As long," he states, "as we admit the non-existence of a Science of Agriculture, and are satisfied with aiding agriculture through teaching and investigation in the sciences related to agriculture, we shall have boards of trustees and college presidents who will be satisfied when their chemists, physicists, and botanists add to their ordinary teaching of the principles of chemistry, physics, and botany a limited amount of information regarding the application of those sciences to agriculture; and the teachers themselves, approaching the subject from the standpoint of the primary or secondary sciences, will be most likely to subordinate the agricultural side of their instruction to the general view of their favourite science; so that the pupils will learn a great deal more about the relations of agricultural subjects to botany and chemistry than they will about the relation of botanical and chemical knowledge to the production of useful plants and animals."

¹ Ann, Rpt. Office of Exp. Stations, 1902, p. 431.

All teachers of zoology and botany will, I think, be the first to admit that any such attempts at teaching the subject are but academical makeshifts, which invariably result in failure. This has been recognized by some of our Universities, and already we see Chairs of Protozoology and Special Lectureships in Parasitology, Economic Zoology, and Economic Botany, and the sooner this becomes more widely recognized the better it will be for all concerned.

There are signs at the present time that the subject of Economic Biology is destined ere many years have elapsed to occupy a very much more important place in our Universities than ever in the past, and also that a new school of biologists is arising, with wider views than those who have preceded them, hence, for a time, at all events, we must expect that some of the old order will look with jealousy upon such an innovation. Such can, however, do little to stem the tide of advancement, for it has become patent to most thinking men and women that a wider and a deeper knowledge of the subject and its application, cannot fail to be of the greatest import.

The Application to Agriculture.—In no Department is its application likely to be fraught with greater and more far-reaching results than in that of Agriculture, for there are signs that we are beginning to realize that "Agriculture is the one industry that never dies. It is the one for the produce of which there is an ever-increasing demand."¹ We are more fully than ever before intelligently grasping the fact that it is our "chief national concern, and the only basis on which the real welfare of a country can be securely established."²

Professor H. H. Armstrong³ has recently reminded us that no career offers "greater opportunities than that of the agriculturist—none is lived under more favourable, more interesting conditions. The problems to be solved are innumerable, and it is of infinite importance to the well-being of mankind that many of them should be solved without delay. Nothing could be further from the truth than to suppose that farming is played out—the opportunity of the agriculturist is but beginning to come. Pursuing, as he does, one of the most difficult of businesses, his being the one profession which is indispensable to mankind, he should be among the most intelligent of workers."

Here is the whole matter in a nutshell, "amongst the most intelligent of workers." There are some, I know, who regard the agriculturist as a most ignorant worker, but those who know him, who are brought into daily contact with him, are of a very different opinion ;

¹ Jesse Collings. Land Reform. London, 1906, p. 38.

² Op. cit., p. x.

³ Science Progress, May, 1907.

indeed, I often think that many business men might take a lesson from the forethought, patience, and steady pertinacity of the British farmer.

Knowledge is power, and there is progressive activity taking place in all branches of human endeavour, and if that knowledge which the successful agriculturist demands is not forthcoming, we are risking the prosperity and wealth of our country.

Theory and Practice.—In the application of Biological Science to agriculture, it is of the greatest importance that we bear in mind that much that seems possible and advisable in theory is scarcely capable of being put into practice, hence in sketching out the lines upon which, I think, the biologist can aid the agriculturist, I have adhered to those which experience has shown me are not only possible but advantageous.

Plant and Animal Breeding.—The first section of which I wish to treat is that of the breeding of plants and animals. The subject of plant and animal breeding is an industry in these islands of enormous magnitude, and its biological side and problems might well form a lecture in itself.

Upon these two subjects there has recently been shed a new light in the application of Mendel's Law that bids fair to revolutionize them. Hitherto the dominant factors in any particular animal or breed have, to a very large extent, been lost sight of. We have muddled horribly in the past. We have been looking after the "general purposes cow" instead of the production of first-rate dairy cattle and high-grade grazing cattle. The horse-breeder and flock-master have trodden in the same path, forgetting that it is not sufficient that the latter should produce only a big sheep, with meat of high quality, and lose sight of the wool and the production of twins.

Hitherto, by an almost rule of thumb method, we have taken elaborate precautions to retain the purity of breed of different stock. The pedigree of the individual has been the criterion upon which we have judged that purity, but "to-day our criterion is an entirely different one. A plant or an animal is pure-bred for any given character when it is has been produced by the union of two gametes, each carrying that character. . . . From a cross between a black and a white rabbit there comes grays in the second generation which breed as true to type as the wild rabbit of irreproachable pedigree. Pedigree is valuable as affording an indication of purity, but the pure-bred thing may, and often does, arise from a stock which is anything but pure. One thing may be pure because of its ancestry, and in spite of its ancestry another may be equally pure."¹

¹ Punnett, R. C.—Mendelism, p. 61.

Splendid results have been achieved by the breeder in the past, who has very largely been working in the dark, with the light of Mendelism to illuminate his experiments in the future, who shall state the limit of his work or estimate its value to mankind?

In plant breeding like problems await the investigator. As regards the production of new varieties, and varieties resistant to disease, there is almost a virgin field. What Mr. R. H. Biffen has done for the botanical side of agriculture is awaiting to be done for the breeder of live stock.

Working on Mendelain lines, Mr. Biffen has, in the course of a few generations, been able to build up and fix wheats which combine the desirable characters of several varieties. He has further shown that the "strength" of the grain, the length of the straw, cropping power, and immunity to rust—are all characters exhibiting Mendelain inheritance. Whenever the pure strains of wheat which he has produced come to be placed upon the market, they cannot fail to exercise a most profound influence upon cereal culture in this country.

The experimental study of heredity is a biological problem fraught with amazing possibilities, "pursued on the lines Mendel has made possible," Mr. Bateson tells us, "it is second to no branch of science in the certainty and magnitude of the results it offers." He continues: "Soon every science that deals with animals and plants will be teeming with discovery, made possible by Mendel's work. The breeder, whether of plants or of animals, no longer trudging in the old paths of tradition, will be second only to the chemist in resource and in foresight."

Diseases of Plants and Animals.—If the breeding of plants and animals offers such scope, what words can I use to adequately represent the vast possibilities that await us in the subject of animal and plant diseases? If we consider the mortality amongst live-stock, and the under average yield of diseased crops, and represent these in pounds sterling as the annual loss to the nation, the figures become stupendous.

I would remind you that we have some £450,000,000 invested in live stock in this country.

That the total acreage under fruit is probably about 300,000 acres, whilst we have 32,000,000 acres carrying cereal, root, and other crops.

The appearance of disease or of any animal life injurious to such stock or crops is a matter of the greatest importance. It may mean ruin to many people and those dependent upon them. Our orchards to-day are suffering to the extent of from 25 to 75 per cent., due to injurious insects and fungi, many of which can be easily and economically checked or controlled.

I have frequently heard it stated that the injuries inflicted by insects and other animals in this country are too insignificant to call for any serious attention. Statistics to controvert such statements are difficult to obtain, but I would point out that nearly fifty years ago John Curtis¹ stated they "annually consume an amount of produce that sets calculation at defiance; and, indeed, if an approximation could be made to the quantity thus destroyed, the world would remain sceptical of the results obtained, considering it too marvellous to be received as truth." If such a statement had any foundation in 1860, it is doubly true to-day. An intimate acquaintance with the condition of the orchards and crops of the seven Midland counties during the past ten years, leaves no doubt in my own mind that tens of thousands of pounds are annually lost, due to the depredations of injurious animals and plants.

As yet we have but an imperfect knowledge of the life-history, etc., of many of the insects and fungi that attack our crops, and without this it is almost impossible to suggest remedial or preventive treatment. The bionomics of such pests must be thoroughly understood if we are to make any real progress.

Another important field for experiment and inquiry is that relating to fungicides and insecticides. Here, in the past, prejudice and ignorance have been only too apparent. One experimenter has vied with another for priority, or with the hope of financial gain, but with never a thought as to the value of the remedy or the useless trouble or expense to which the fruit-grower or farmer would be put, and the ultimate failure which would only discredit the practice of spraying in their eyes. Fortunately, present-day fruit-growers are fully wide-awake to such methods, and slowly but surely, and as the result of carefully planned and thought-out experiments, we are placing the subject upon a sound and scientific base, with results as sure as those to be obtained from manuring, ploughing, and other farm practices. Personally I have every faith in the practice of spraying and soil fumigation for combating animal and vegetable pests, and ere many years have passed we shall see these two practices resorted to as annual ones, just as ploughing and harrowing are. Let those who doubt these statements experiment carefully with the proper materials, and note the results. They will require no other evidence than fruit trees laden with an abundance of sound, healthy fruit, equal, if not superior to, that produced by any other fruit-growing country in the world.

Whilst in the past we have neglected the study of these injurious

¹ Farm Insects.

forms of life, so have we exhibited an almost total disregard to those which are beneficial. This is particularly true as regards birds and insects. Our insect-feeding birds are few in numbers as compared with those that feed on grain, fruit, and other vegetable produce. These latter are annually becoming a more potent factor, and a very serious one from the standpoint of the farmer and fruit-grower.

Insect Enemies of Insects.—Apart from the little work we have carried on at Birmingham on the breeding and distribution of insect enemies of insects, but little attention has been paid to the subject in this country, and yet the results that have been achieved in America are little short of marvellous, and read more like a fairy tale than the sober facts of science. One by one the original home of different injurious insects has been run down, and its natural insect enemy or enemies discovered. These latter have then been shipped to Washington, bred, and distributed, with the result that some of the worst pests have been held in check, whilst in certain districts they have been almost exterminated. In the Californian fruit-growing district the well-known Cottony Cushion Scale (*Icerya purchasi*) has been held in check by a small Australian Ladybird (*Vedalia cardinalis*). Before the introduction of this small beetle the citrus industry of California was threatened. In a like manner various aphids, the Black Scale, Mealy Bugs, Red "Spider," the Tent Caterpillar, the Cabbage Butterfly, and many other insect pests have been attacked. So successful has this method proved that a member of the Californian State Commission of Horticulture recently stated: "This method has been found so effective that we have now very few really troublesome orchard pests, the worst at the present time being the Codling Moth, and for this we hope to find a natural check."

In California the method employed has been as follows:—An endeavour is made to trace back the course travelled over by the pest, and to trace them to their native country; there the check is to be found. This check, whether it be a parasitic or a predaceous insect, or both, as sometimes found, is secured, introduced into the insectary, and bred with care. It soon becomes acclimatised to its new home, and as the species propagates itself it is sent out into those sections of the country where the pest it attacks is most prevalent. So effective has this work of introducing beneficial insects and encouraging native parasites been, that in California they have practically reduced all the worst of the Scale insects and very many other injurious species, so that they are no longer a source of serious danger.

This is a subject which sooner or later will come to the front in this country. Already in Evesham, Kent, and other fruit-growing

districts growers are fully alive to its importance, and are seeking information. Surely our crops are just as important as those of other countries. Why should we allow ours to be destroyed, and then be content to import our fruit from abroad?

Biology of the Soil.—Turning next to a very brief *résumé* of soil biology, I would remark in passing that excellent results have been obtained during recent years by the chemist and agriculturist, though, I think, speaking generally, that we have as yet scarcely realized the importance of a more exact knowledge of the soil from every possible standpoint. The United States Department of Agriculture in 1901 established a Bureau of Soils, its staff consisting of a chief, a chief clerk, 92 scientific experts and 28 clerks, and excellent work is being done by Dr. Whitney and his colleagues. Such questions as the movement of water in soils, the effect of tillage, the control of evaporation, the reclamation of alkali lands, soil fertility, the aeration of soils, etc., have already received attention.

But as a biologist, it is the life-history and behaviour of the living organisms that appeal to me; the various kinds of bacteria and their action on plant food and plants; the moulds and other fungi. Just as there are animals which are beneficial and others that are injurious, so there are soil bacteria. Of the beneficial kinds we are beginning to know something, but there is an almost unexplored field in the difficult subjects of the injurious forms.

Such, then, are a few of the possibilities of the Economic Biologist; it is impossible here to enter into any more detailed account of the multifarious lines of biological research that bear upon agriculture, but sufficient, I think, has been said to at least indicate how complex the subject is, and how great the need for further work and workers.

The field is an ever-widening one, the possibilities vast, and the need pressing, why delay? why hesitate?

To-day, in this great mercantile city, you are laying the foundation of what I hope will ere long grow to be a centre of research, experiment, and information for the whole of the Western Counties of England.

Whilst far from a worshipper of bricks and mortar, I hope that here we shall see spacious and well-equipped laboratories, museums, and experimental farms arise, such a department may I liken to a forge, where, within the walls of research, the ring of the anvil of truth and the roar of the bellows of inquiry are ceaseless.

On the same lines we have established a somewhat similar department in connection with the University of Birmingham, the first such

that has ever been established in connection with any British University. Let us hope that the time is not far distant when we shall see similar departments for the South-Eastern, Eastern, and Northern Counties, knit together by an active and living State Department of Agriculture; then, and then only, shall we take our place in the front rank in the march to progress and fame.

I understand that your Department of Economic Biology has been planned out on very similar lines to those I have laid down at Birmingham. Some months back you paid me the honour of inviting me to lay before your Committee my views on the scope and work of such a department, and with some slight variations to meet the special and local needs of your work, such, I understand, will be the lines upon which you will develop in the future.

Might I venture to press home one great truth to which the late Sir Michael Foster¹ gave utterance. "As the University looks to be treated by the world, so it must treat those who do its work. Since it lives for the advance of knowledge, it must see to it that the men who are for the time being its flesh and bones are placed in circumstances so far as possible favourable for their doing their best to push forward the limits of the known. Part of these men's work is, as we have seen, available for immediate use, and as such may be duly appraised; but the value of much of it lies hidden in the future. It is just this uncertain moiety which needs the most kindly care. The worth of a University is to be measured not alone by the number and quality of the graduates which it turns out into the world, but also and even more so by the number and quality of the new truths which go out into the world from its laboratories and lecture rooms; by its work of research will it in the end be judged. Research grows on leisure and quiet; only in rare cases will it flourish in the midst of turmoil and with the wolf crying at the door. By all means, as I have already urged, let teaching and learning stand side by side; bid the teacher investigate, and the investigator teach; but let the teaching be so ordered and so rewarded that the teacher has ample time and repose for his research, and, content with his hire, is placed beyond the temptation of giving up to the search for gold the time and energy which ought to be spent in the pursuit of truth."

With such a magnificent field as the Western Counties of England there are vast possibilities before you. But a Department such as this cannot live from hand to mouth or flourish on good wishes, and

¹ In an Address to the Students of Mason University College, Birmingham, on October 3rd, 1898.

I sincerely trust that the County Councils and State will willingly and promptly render such assistance, so as to at once assure its livelihood.

With the spirit of inquiry as your guiding spirit, and the rendering of nothing short of your best, you will reap a just reward, and at the same time light yet another torch to show in what an infinity of ways the farmer, fruit-grower, and stock-breeder may benefit from a well-equipped and adequately staffed institution devoted to the application of Economic Biology to Agriculture.

With Thoreau, I would say in conclusion, "I do not say that John or Jonathan will realize all this; but such is the character of that morrow which mere lapse of time can never make to dawn. The light which puts out our eyes is darkness to us. Only that day dawns to which we are awake. There is more day to dawn. The sun is but a morning star."

REVIEWS AND CURRENT LITERATURE.

I.—GENERAL SUBJECT.

Gordon, W. J.—Manual of British Grasses. Pp. xii + 180, 33 pls. and 83 text figs. London: Simpkin, Marshall and Co., Ltd., 1907.

The author has not at all been successful in the treatment of a subject in which there was a distinct field for a clearly and simply written manual.

The extraordinary arrangement adopted makes the work very difficult to consult, whilst the careless manner in which the matter has been put together seriously detracts from any value it may possess. The plates are certainly the most useful part of this book.

W. E. C.

II.—ANATOMY, PHYSIOLOGY, AND DEVELOPMENT.

Barber, C. A.—Studies in Root-Parasitism. The Haustorium of *Santalum album*. Part 2. The Structure of the Mature Haustorium and the Inter-relations between Host and Parasite. Mem. Dept. Agric. India, Botan. Ser., 1907, vol. i, pp. v + 58, pls. i-xvi.

Bezzi, M.—Intorno al tipo della *Echinomyia faolilli*, A Costa. Ann. Mus. Zool. Univ. Napoli, 1906, vol. 2, pp. 1, 2.

Dürken, B.—Die Tracheenkiemenmuskulatur der Ephemeriden unter Berücksichtigung der Morphologie des Insektenflügels. Zeit. f. wiss. Zool., 1907, pp. 435-550, T. xxiv-xxvi., u. 30 fig.

Hart, William.—The Internal Structure of some Insects' Heads, as revealed by the Microscope. Trans. Manchester Micros. Soc. 1906, 1907, pp. 84-86, plt. ii, and 1 fig.

Henderson, W. D.—Zur Kenntnis der Spermatogenese von *Dytiscus marginalis*, L., nebst einigen Bemerkungen über den Nucleolus. Zeit. f. wiss. Zool., 1907, pp. 644-684, T. xxxii, xxxiii, u. 5 fig.

Hewitt, C. G.—The Structure, Development, and Bionomics of the House-fly, *Musca domestica*, Linn. Part 1. The Anatomy of the Fly. Quart. Journ. Micros. Sci., 1907, vol. 51, pp. 395-448, pls. 22-26.

Imms, A. D.—Notes on the Structure and Behaviour of the Larva of *Anopheles maculipennis*, Meigen. Proc. Camb. Phil. Soc., 1907, vol. xiv, pp. 292-295.

Kershaw, J. C. W.—The Life-history of *Spindasis lohita*, Horsf. Trans. Entom. Soc. Lond., 1907, pp. 245-248, plt. xxii.

Kershaw, J. C.—Life-history of *Tessarotoma papillosa*, Thunberg. Ibid., pp. 253-255, plt. xxiii.

- Köhler, Anton.**—Untersuchungen über das Ovarium der Hemipteren. Zeit. f. wiss. Zool., 1907, pp. 337-381, T. xix, xx.
- MacDougall, R. S.**—Parthenogenesis in *Lophyrus pini*, the Pine Sawfly. Proc. Assoc. Econ. Biol., 1907, vol. i, pp. 124-125.
- Mark, E. L., and Copeland, M.**—Maturation Stages in the Spermatogenesis of *Vespa maculata*, Linn. Proc. Amer. Acc. A. & S., 1907, vol. xliii, pp. 71-74, 8 figs.
- Miall, L. C., and Taylor, T. H.**—The Structure and Life-history of the Holly-fly. Trans. Entom. Soc. Lond., 1907, pp. 259-283, 20 figs.
The authors seem to regard this fly as the *Phytomyza aquifolii* of Goureaux, whereas it has been generally known as *Chromatomyia ilicis*, Curtis. No mention is made of Curtis or of the account of the life-history given by Collinge in 1906.
- Muir, F.**—Notes on the Stridulating Organ and Stink-glands of *Tessaratoma papillosa*, Thunb. Trans. Entom. Soc. Lond., 1907, pp. 256-258, 3 figs.
- Petersen, W.**—Über die Spermatophoren der Schmetterlinge. Zeit. f. wiss. Zool., 1907, pp. 117-130, T. viii, u. 2 figs.
- Philipschenko, Jur.**—Über die excretorischen und phagocytären Organe von *Ctenolepisma lineata*, F. Zeit. f. wiss. Zool., 1907, pp. 97-116, T. vii.
- Stauffacher, Hch.**—Zur Kenntnis der *Phylloxera vastratrix*, Pl. Zeit. f. wiss. Zool., 1907, pp. 131-152, T. ix, u. 5 figs.
- Unwin, E. E.**—The Vinegar-fly (*Drosophila funebris*). Trans. Entom. Soc. Lond., 1907, pp. 285-302, 15 figs.

III.—GENERAL AND SYSTEMATIC BIOLOGY, AND GEOGRAPHICAL DISTRIBUTION.

- Banks, N.**—A Catalogue of the Acarina, or Mites, of the United States. Proc. U.S. Nat. Mus., 1907, vol. xxxii, pp. 595-625.
The author catalogues 450 species, grouped in 133 genera, though this is probably, as the author remarks, less than a third of the entire acarid fauna of the United States. We note that there are only 28 species of *Eriophyidae* recorded, which certainly cannot represent more than a fourth of the species.
- Barber, C. A.**—Parasitic Trees in Southern India. Proc. Camb. Phil. Soc., 1907, vol. xiv, pp. 246-256, pls. i-iii.
- Bezzi, M.**—Die Gattungen der blutsaugenden Musciden. Zeit. f. Hymen. u. Dipt., 1907, pp. 413-416.
Haematobosca, n. gen.
- Brooks, F. T.**—Notes on the parasitism of *Botrytis*. Proc. Camb. Phil. Soc., 1907, vol. xiv, p. 298.

- Carpenter, G. H.**—Collembola from the South Orkney Islands. Proc. Roy. Soc. Edinb., 1906, vol. xxvi, pp. 473-483, pls. i, ii.
The new species are *Isotoma brucei* and *Cryptopygus crassus*.
- Crawshay, G. A.**—The Life-history of *Tetropium gabrieli*, Ws., = *T. fuscum*, Sharp, = *T. crawshayi*, Sharp, etc. Trans. Entom. Soc. Lond., 1907, pp. 183-212, pls. xv-xx.
- Felt, E. P.**—New Species of *Cecidomyiidae*. N.Y. State Mus., Entom. Bull. 28, 1907, pp. 97-165.
The author describes as new 213 species. The descriptions are preliminary ones—mostly very brief—in advance of an extended monograph on the group.
- Girault, A. A.**—*Trichogramma pretiosa*, Riley: Seasonal History. Psyche, 1907, vol. xiv, pp. 80-86.
- Girault, A. A., and Rosenfeld, A. H.**—Biological Notes on the Colorado Potato Beetle, *Leptinotarsa decemlineata* (Say), with technical description of its stages. Psyche, 1907, vol. xiv, pp. 45-47.
- Hine, J. S.**—Second Report upon the Horseflies of Louisiana. Louisiana Agric. Exp. Stat., Bull. No. 93, 1907, pp. 3-59, 37 text figs.
The present paper is a valuable contribution respecting the breeding habits, life-histories and natural enemies of certain species of *Tabanidae*. Thirteen species of *Chrysops* and twenty-seven of *Tabanus* are treated of.
- Howard, L. O.**—New Genera and Species of *Aphelininae*, with a revised table of Genera. U.S. Dept. Agric., Bur. of Entom., Tech. Ser. No. 12, pt. IV, 1907, pp. 69-88, figs. 13-22.
The author describes twenty new species and five new genera of these interesting insects, together with a revised table of the genera. This table applies only to females. In many genera the males are unknown, and as a rule females are reared in infinitely greater numbers than males, affording, in Dr. Howard's opinion, a strong suspicion that alternation of generations accompanied by parthenogenesis may hold with a number of species.
- Kieffer, J. J.**—Description d'une cecidomyie nouvelle vivant sur le Geranium. Marcellia, 1907, vol. vi, pp. 44, 45.
Perrisia geranii, n. sp.
- Kirkaldy, G. W.**—Hints on the Study of Leaf-hoppers. Entomol., 1907, vol. xl, pp. 225-227.
- Kirkaldy, G. W.**—A Catalogue of the Hemipterous Family *Aleyrodidae*. Bd. Comms. Agric. and For. Hawaii, Bull. No. 2, Div. of Entom., 1907, pp. 3-92.
A valuable and useful compilation, but it is a pity there are so many printer's errors.

Kotinsky, Jacob.—*Aleyrodidae* of Hawaii and Fiji, with descriptions of new species. *Ibid.*, pp. 93-103, pl. i.

Six new species are described.

MacDougall, R. S.—On the length of life of *Calandra granaria*. *Proc. Assoc. Econ. Biol.*, 1907, vol. 1, pp. 125-126.

Mann, H. H.—Individual and Seasonal Variations in *Helopeltis theivora*, Waterhouse, with description of a new species of *Helopeltis*. *Mem. Dept. Agric. India, Entom. Ser.*, 1907, vol. i, pp. 275-337, pl. xv, 5 text figs.

The genus *Helopeltis* belongs to a family of heteropterous bugs which are serious pests to several cultivated tropical crops, such as tea, cocoa, etc. The author's plan has been to obtain a large monthly supply from various planters and districts. Twenty or thirty examples have been taken from each catch and notes made on the colour, and various parts accurately measured.

The individual and seasonal variation is first described in both male and female; the variations due to locality and change of food. The relationship between *H. theivora* and *H. antonii* is pointed out, and a new species—*H. cinchonae*—described and figured.

Marlatt, C. L.—The Periodical Cicada. U.S. Dept. Agric., Bur. of Entom., Bull. No. 71, 1907, pp. 1-181, 7 plts. and 68 figs.

If there is one character more than another that stands out conspicuously in the publications of the U.S. Department of Agriculture, it is thoroughness. Many institutions in the States publish bulky volumes, but they contain little that is new or useful, indeed, they would often fulfil their mission better if considerably reduced in size.

The volume before us is really a revised edition of the author's work published in 1898, with a considerable amount of new matter and many new illustrations.

The author points out that in the curious features of its life-history the periodical Cicada is undoubtedly the most anomalous and interesting of all the insects peculiar to the American Continent. A summary of the habits and characteristics is first given; the author then passes on to consider the races, broods, and varieties; the relation of climate to the races; the broods; the distribution; the systematic position and structural details; the song notes, etc.

The adult insect and its habits are next treated of, and full details given on the oviposition and its effect on the plant; the growth and hatching of the eggs, the underground life of the Cicada; the history of the larval and pupal stages; and the habits of the larva and pupa.

Most interesting is the information furnished as to the insect and mite parasites, and the fungous disease of the adults.

Remedies and preventives are fully set forth, together with a concise account of the literature on this insect, and a full bibliography from 1666 to 1906.

Dr. Marlatt is to be heartily congratulated on this the latest of his many valuable and important contributions to the literature on Economic Entomology.

W. E. C.

Massalongo, C.—Nuova contribuzione alla conoscenza degli zoocedii del nizzardo. Marcellia, 1907, vol. vi, pp. 33-44.

Rainbow, W. J.—Two new species of Collembola. Rec. Austr. Mus., 1907, vol. vi, no. 4, pp. 313, 314, figs. 49-52.

The new species are *Isotoma troglodytica* and *Achorutes speciosus*.

Scott, Hugh.—On *Cercococcus eremobius*, gen. et sp.n., an Aberrant Form of *Coccidae*. Trans. Linn. Soc., 2nd Ser. Zool., 1907, vol. ix, pp. 455-464, plt. 34.

Silvestri, F.—La Tignola dell' Olivo (*Prays oleellus*, Fabr.): Boll. Lab. Zool. gen. e agrar., Portici, 1907, vol. ii, pp. 83-184, 68 figs.

Silvestri, F.—Descrizione di una nuova specie di *Margarodes* avente la prima forma larvale bipeda. Bull. Soc. Entom. Ital., 1906, vol. xxxviii, pp. 140-152, 10 figs.

Prof. Silvestri describes under the name of *Margarodes mediterraneus*, sp.n., a new coccid, the larval form of which is characterised by the possession of a single pair of legs.

Thompson, M. T.—Three Galls made by Cyclorrhaphous Flies. Psyche, 1907, vol. xiv, pp. 71-74, figs. 1-3.

Trotter, A.—Nuovi Zoocedii della Flora italiana. Marcellia, 1907, vol. vi, pp. 25-32.

IV.—AGRICULTURAL AND HORTICULTURAL.

Berlese, Antonio.—Intorno agli esperimenti contro la Mosca delle Olive (*Dacus oleae*, Rossi). Proc. Assoc. Econ. Biol., 1907, vol. i, pp. 107-109.

Bezzi, M.—Mosche Ematofaghe. Rend. R. Inst. Lomb. Sci. e. Lett., 1907, ser. ii, vol. xl, pp. 1-30.

Butler, E. J., and Lefroy, H. M.—Report on Trials of the South African Locust Fungus in India. Agric. Research Inst., Pusa, Bull. No. 5 of 1907, pp. 1-5.

The experiments carried out by the authors show that the fungus *Mucor exitiosus*, Masee, does not appear capable of making a good growth, even when inoculated into wounds; that the spores may be eaten with impunity by all the species tested; and that locusts, living in a moist atmosphere charged with spores, flourish even when sprayed with

the spores. Even allowing that the few deaths which occurred were due to the fungus, it is clear that the method is too uncertain to be of any assistance in the field, where nothing but the most virulent infective power is likely to be of value. The conditions in nature, the authors conclude, are much more in favour of the insect, and against the fungus, than those under which the experiments were made, and if we can only anticipate a small percentage of infections the method will certainly fail. Against the Bombay Locust, the Black Spotted Grasshopper and the Rice Grasshopper, it is entirely useless.

Carpenter, G. H.—Injurious Insects and other Animals observed in Ireland during the year 1906. *Econ. Proc. Roy. Dublin, Soc.*, 1907, vol. i, pp. 421-452, pls. xxxix-xliv, and 11 text figs.

Chittenden, F. H.—Some Insects Injurious to Truck Crops. *U.S. Dept. Agric. Bur. of Entom., Bull. No. 66*, pt. iii, 1907, pp. 21-32, 2 figs.

Collinge, Walter E.—Report on the Injurious Insects and other Animals observed in the Midland Counties during 1906. Pp. vii + 46, 7 pls and 9 text figs. Birmingham: Cornish Bros., Ltd., 1907.

Dreyer, T. F.—Poisoned Bait for the Fruit Fly. *Agric. Journ. Cape of Good Hope*, 1907, pp. 2-4. (Reprint).

Felt, E. P.—White Marked Tussock Moth and Elm Leaf Beetle. *N.Y. State Mus. Entom. Bull. 27*, 1907, pp. 5-31, pls. 1-8.

Felt, E. P.—22nd Report of the State Entomologist on Injurious and other Insects of the State of New York, 1906. *N.Y. State Mus., Entom. Bull. 28*, 1907, pp. 39-186, pls. 1-3.

Fisher, A. K.—Hawks and Owls from the Standpoint of the Farmer. *U.S. Dept. Agric., Biol. Sur., Circ. No. 61*, 1907, pp. 1-18.

Furley, K. G.—Report on the Experimental Spraying for the Apple Sucker. *Worcestershire Education Comm.*, 1907, pp. 1-26, 9 figs.

The author concludes this report by stating: "I think that the experiments have shown clearly that, as regards their action on the 'Psylla' ova, the following washes are absolutely useless, and may therefore be discarded:—The Ordinary and Double Strengths of Caustic Soda, the three Strengths of Paraffin Emulsion, the Lime and Paraffin, the combined Paraffin and Soda, and the Lime, Sulphur, and Caustic Soda. The last-named wash was the only one of those mentioned above which was seen to have any effect at all on the ova, and in this case to hardly any appreciable extent; while the Lime and Salt wash has undoubtedly proved itself to be the only wash at present capable of checking the ravages of this most serious pest."

This last mentioned fluid cost 1s. 11d. per 100 gallons, but as an ordinary Standard tree requires about 15 gallons, it works out at about 3½d. per tree, about three times the cost the fruit grower can afford to expend.

Anyone who has had any practical knowledge of insecticides or experience in spraying, could have told the author that the six washes set forth on p. 7 were absolutely useless, and thus have saved him a useless series of experiments, and the ratepayers of Worcestershire a considerable sum of money.

W. E. C.

Green, E. E., and Mann, H. H.—The *Coccidae* attacking the Tea Plant in India and Ceylon. Mem. Dept. Agric. India, Entom. Ser., 1907, vol. i, no. 5, pp. 337-355, pls. xvi-xix.

Halsted, B. D., and Owen, E. J.—Report of the Botanist. 27th Ann. Rpt. New Jersey State Agric. Exp. Stat. for 1906, 1907, pp. 369-514, pls. i-xxv.

Hooper, C. H.—Birds in Relation to the Farm, the Orchard, the Garden, and the Forest. Agric. Student's Gaz., 1907, pp. 1-8. (Reprint).

Hunter, W. D.—The most important step in the Control of the Boll Weevil. U.S. Dept. Agric., Bur. of Entom., Circ. No. 95, 1907, pp. 1-8.

Lefroy, H. M.—Locusts in India. Agric. Journ. India, 1907, vol. ii, pp. 238-245, pls. xiv-xx.

Lefroy, H. M.—The Pests of Introduced Cottons. *Ibid.*, pp. 283-285.

Lefroy, H. M.—Indian Insect Pests. Pp. vii + 318, and 346 + 19 illustrations. Calcutta: Office of the Superintendent of Government Printing, 1906. Price 2s.

Indian agriculturists and planters are placed under a debt of gratitude to the Imperial Entomologist, Mr. H. Maxwell Lefroy, for this very useful work. As Mr. F. G. Sly remarks, in an introduction written by him, this "is not a scientific treatise on Entomology, . . . but is intended to serve the more humble but useful purpose of a manual of practical information for the use of the intelligent agriculturist in the protection of his crops from insect pests."

Whilst fully agreeing with this statement it must not be supposed that the work is merely a compilation, far from it, for it abounds with original observations of great value.

The work is divided into four parts, the first treating of Insects in General. Here the structure, food, life-history, form and classification are dealt with. This is followed by a practical account of the origin of insect pests, preventive and remedial measures, and an account of insecticides and spraying.

Parts III and IV, which constitute the bulk of the work, give a detailed account of the insect pests of different crops, those infesting grain, attacking cattle, and beneficial insects.

There are two useful appendices giving information on insecticides, and instructions for collecting and preserving insects; a general index and a list of the illustrations and one of plants.

Only those who have been engaged in pioneer work of this character can appreciate the many difficulties which have to be overcome before the production of a work such as this is possible, and we offer Mr. Lefroy our heartiest congratulations on the completion of an exceedingly practical and valuable work, which must form the basis for all future work of a more detailed or extended character.

W. E. C.

Lipman, J. G.—Report of the Soil Chemist and Bacteriologist. 27th Ann. Rpt. New Jersey State Agric. Exp. Stat. for 1906, 1907, pp. 117-187.

L[ounsbury], C. P.—South African Inter-Colonial Plant Import Regulations, also Plant Conveyance Regulations. Agric. Journ. Cape of Good Hope, 1907, pp. 3-8. (Reprint).

L[ounsbury], C. P.—Over-sea Plant Import Regulations. Ibid., pp. 3-7. (Reprint).

L[ounsbury], C. P.—Caterpillars destroying Trees. Ibid., pp. 3-6. (Reprint).

MacDougall, R. S.—The Fruit Fly. Journ. Bd. of Agric., 1907, vol. xiv, pp. 297-300.

Mann, H. H., and Hutchinson, C. M.—*Cephaleuros virescens*, Kunze, the "Red Rust" of Tea. Mem. Dept. Agric. India, Botan. Ser. 1907, vol. i, No. 6, pp. 1-35, pls. i-viii, and 2 figs.

The authors treat of the history and life-history of this disease in great detail in addition to the economical side.

Mayer, ——The most important factor in solving the Boll Weevil Problem. State Crop Pest Comms. of Louisiana, Circ. No. 16, 1907, pp. 1-8.

Mukerji, N. G.—A Bird's-Eye View of Indian Sericulture. Pp. 33, 28 text figs. Calcutta: Thacker, Spink and Co., 1907.

This brochure gives a short general account of Indian Sericulture in a concise and very readable form. Indian Silkworms fall under two groups, viz. :—The *Attacidae*, which spin unreelable cocoons, and the *Bombycidae*, which provide the readily reelable silk. The author enumerates eight species of Mulberry-feeding silkworms used in India, seven of these belonging to the genus *Bombyx*, while the eighth is a species of *Theophila*, which is wild on the mulberrys of the Himalayas.

The remaining Indian *Bombycidae* are termed " Tusser " silkworms, and all belong to the genus *Antheria*. Indian silkworms are prone to many diseases, and the author enumerates pebrine (Bengali *Kata*), Muscardine (*Chunakati*), flacherie (*Kalsira*), gatine (*Sulpha*), and grasserie (*Rasa*). A Tachinid fly (*Tricolyyga bombycis*) is parasitic on silkworms, and does very great injury to the industry in Bengal.

A. D. IMMS.

- Newell, W.**—Fighting the Boll Weevil by picking up the infested squares. State Crop Pest Comms. of Louisiana, Circ. No. 15, 1907, pp. 1-4.
- Newell, W.**—Protecting the Cotton Crops against the Boll Worm. State Crop Pest Comms. of Louisiana, Circ. No. 19, 1907, pp. 1-4.
- Quaintance, A. L.**—The Spring Canker-Worm. (*Paleacrita vernata*, Peck). U.S. Dept. Agric., Bur. of Entom., Bull. No. 68, pt. II, 1907, pp. 17-22, pls. iii, iv.
- Quaintance, A. L.**—The Trumpet Leaf-Miner of the Apple. Ibid., Bull. No. 68, pt. III, 1907, pp. 23-30, plt. v, and 1 fig.
- Reh, L.**—Insecten-Schäden in Frühjahre, 1907. Naturw. Zeit. f. Land- und Forstw., 1907, pp. 492-499.
- Reh, L.**—Die Sackmotten. Der praktische Ratg. un Obst-und Garten., 1907, pp. 338-340, 6 figs.
- Rosenfeld, A. H.**—The White Fly and its Treatment. State Crop Pest Comms. of Louisiana, Circ. No. 18, 1907, pp. 1-18, 7 figs.
Treats of *Aleyrodes citri*, R. & H.
- Salmon, E. S.**—Report on Economic Mycology for the Year ending April 1st, 1907. Journ. S.E. Agric. Coll. Wye, 1907, pp. 267-332, 22 pls., and 5 text figs.
- Smith, J. B.**—Report of the Entomologist. 27th Ann. Rpt. New Jersey State Agric. Exp. Stat. for 1906, 1907, pp. 515-609, 33 figs.
- Smith, John B.**—Some Household Pests. New Jersey Agric. Exp. Stat. Bull. 203, 1907, pp. 3-48, 31 figs.
- The State Crop Pest Law of Louisiana.**—State Crop Pest Comms. of Louisiana, Circ. No. 17, 1907, pp. 1-19.
- Theobald, F. V.**—Report on Economic Zoology for the Year ending April 1st, 1907. Journ. S.E. Agric. Coll. Wye, 1907, pp. 31-178, 29 pls., and 20 text figs.
- Amongst the most interesting features in this Report we would mention the record of *Strongylus ostertagi* in sheep; a species (probably new) of *Cecidomyia* attacking gooseberries, and an interesting and peculiar attack of *Eriophyes ribis* (Nalepa) on red currants.
- Warren, G. F.**—Report of the Horticulturist. 27th Ann. Rpt. New Jersey State Agric. Exp. Stat. for 1906, 1907, pp. 109-266, 8 figs.

Contains some interesting and useful notes on fumigating with hydrocyanic acid gas.

Webster, F. M.—The Spring Grain-aphis or so-called "Green-bug." U.S. Dept. Agric., Bur. of Entom., Circ. No. 93, 1907, pp. 1-18, 7 figs.

Weiss, F. G.—Immunity to Disease among Plants. *Nature*, 1907 (Nov. 7th), pp. 20, 21.

V.—FORESTRY.

Bennett, J.—*Argyresthia laevigatella* on the Larch. *Q. Journ. Fores.*, 1907, vol. i, pp. 205-207.

Gillander, A. T.—Notes on *Scotyidae* or "Bark-beetles." *Trans. Manchester Micros. Soc.* 1906, 1907, pp. 69-75.

Somerville, Wm.—Insect on the Larch. *Q. Journ. Fores.*, 1907, vol. i, pp. 204-205.

VI.—FISHERIES.

Gilchrist, J. D. F.—Report of the Government Biologist of the Cape of Good Hope on the Inland and Marine Fisheries for the Year 1906. Pp. 44. Cape Town, 1907.

Nelson, J.—Experimental Studies in Oyster Propagation. 27th Ann. Rpt. New Jersey State Agric. Exp. Stat. for 1906, 1907, pp. 313-354, pls. i-xiv.

Shipley, A. E.—Sea Fisheries. *Proc. Assoc. Econ. Biol.*, 1907, vol. i, pp. 87-105.

VII.—MEDICINE.

Berg, S.—Gesetz betreffs der vertilgung von Ratten in Konigreiche Danemark nebst erlanterungen zur praktischen durchfuhrung dieses gesetzes. Pp. 15, Copenhagen: 1907.

Fearnside, E. G.—The Blood Changes in Man caused by the presence of Metazoan parasites, and their aid in diagnosis. *Proc. Assoc. Econ. Biol.*, 1907, vol. i, pp. 126-137.

Hassack, W. C.—Aid to the Identification of Rats connected with the Plague in India, with Suggestions as to the Collection of specimens. Pp. 10, 3 plates. Published by the Trustees of the Indian Museum. Printed at the Pioneer Press, Allahabad, 1907.

This pamphlet is issued in order that our knowledge of Indian rats, especially those concerned with plague, may be extended and placed on a more accurate basis. A large amount of information is necessary to justify final and definite conclusions on this important subject.

A. D. IMMS,

- Lantz, D. E.**—Methods of Destroying Rats. U.S. Dept. Agric., Farmer's Bull. 297, 1907, pp. 1-8.
- Seal, W. P.**—Report upon an Experiment having for its object the Introduction of *Gambusia affinis* and *Heterandria formosa* to the Waters of New Jersey as Destroyers of *Anopheles* larvae. 27th Ann. Rpt. New Jersey Agric. Exp. Stat. for 1906, 1907, pp. 653-670, 14 figs.
- Smith, J. B.**—Report of the Mosquito Investigation in 1906. 27th Ann. Rpt. New Jersey Agric. Exp. Stat. for 1906, 1907, pp. 611-652, 7 figs.
- Van Dine, D. L.**—The Introduction of Top-Minnows (Natural Enemies of Mosquitoes) into the Hawaiian Islands. Hawaii Agric. Exp. Stat., Press Bull. No. 20, 1907, pp. 1-10, 3 figs.
- Gives a short account of the successful introduction of three species of Top-Minnows, viz., *Mollienesia latipinna*, *Fundulus grandis*, and *Gambusia affinis*. These have multiplied rapidly, and from the few hundred introduced, several hundred thousand have been bred and distributed. Where they occur they effectively clear the water of the mosquito larvae, feeding also on the egg-masses of *Culex pipiens* on the surface.
- Zuschlag, E.**—Le Rat Migratoire et sa destruction rationnelle. Pp. 154, Copenhagen: 1907.

VIII.—ANIMAL DISEASES.

- Banks, N.**—Mites and Lice on Poultry. U.S. Dept. Agric., Bur. of Entom., Circ. No. 92, 1907, pp. 1-8, 6 figs.
- Special Report on Diseases of the Horse** by DRs. PEARSON, MICHENER, LAW, HARBAUGH, TRUMBOWER, LIAUTARD, HOLCOMBE, HUIDEKOPER, STILES, MOHLER, and ADAMS. Revised Edition. U.S. Dept. Agric., Bur. of An. Indus., 1907, pp. 608, 41 pls. and 18 text figs.

A further revised edition of this well-known work, first issued in 1890 and revised in 1903, is sure of a hearty reception by all interested in horses. It is well illustrated and printed, and may be obtained from the Government Printing Office, post free, for the modest sum of three shillings and sixpence.

It is impossible to review such a work in the space at command, so we must content ourselves with a bare enumeration of the titles and authors of the different chapters, which are as follows:—

The Examination of a sick horse, by Dr. Leonard Pearson; Methods of administering medicines, Diseases of the digestive organs, Wounds and their treatment, all by Ch. B. Michener; Diseases of the urinary organs, Diseases of the generative organs, Disease of the eye, Diseases of the skin, all by Mr. James Law; Diseases of the respiratory organs, by W. H. Harbaugh; Diseases of the nervous system, and Diseases of the heart,

blood vessels, and lymphatics, by M. R. Trumbower; Lameness, by Dr. Liautard; Diseases of the fetlock, ankle, and foot, by Dr. Holcombe; General Diseases, by Dr. Huidekoper; Surra, by Dr. Stiles; Osteoporosis or bighead, by Dr. Mohler; and Shoeing, by Dr. J. W. Adams; and an excellent index.

Morse, G. B.—Quail Disease in the United States. U.S. Dept. Agric., Bur. An. Indus., Circ. No. 109, pp. 1-11, 3 figs.

This is a preliminary report upon a highly contagious and rapidly fatal disease that has recently prevailed among quail in the United States. Hitherto it has not been recognised, and it is possibly new to the country, its enzootic character, however, makes it a matter of grave concern to sportsmen, owners of hunting preserves, etc.

In many essential features the disease resembles the British grouse disease. It is caused by a bacillus of the *B. coli* group, viz., *Colibacillus tetraonidarum*, and characterised by congestion of the lungs, focal necroses of the liver, and intestinal ulceration.

Particulars are given of the post-mortem appearances, treatment, and suggested procedure for prevention.

Stiles, C. W., and Hassall, A.—Index-catalogue of Medical and Veterinary Zoology. U.S. Dept. Agric., Bur. of An. Indus., Bull. 39, pts. 17-19, 1907, pp. 1209-1492.

The further the authors proceed, the more invaluable does this great work become.

THE

JOURNAL OF ECONOMIC BIOLOGY.

SOME CRITICAL OBSERVATIONS ON THE EUROPEAN SPECIES OF THE GENUS CHERMES.

By

E. R. BURDON, M.A., F.L.S.

WITH PLATES VIII AND IX.

CONTENTS.

	PAGE		PAGE
Introduction - - - -	119	B. Species or Varieties. - - -	137
A. Tables giving summaries of—		(I) The Characters provided	
(a) the habits and characters		by the Galls - - -	139
of the Genus - - -	122	(a) their size, shape, colour,	
(b) Cholodkovsky's descrip-		etc. - - -	139
tions of species occurring		(b) Effect of the position of	
in Europe - - -	124	the Fundatrices in rela-	
Critical Observations and Re-		tion to the buds - - -	142
ferences to the species		(c) Dehiscence of the Galls	143
occurring in England -	135	(II.) The Characters provided	
Explanation of Plates - -	147	by the Insects - - -	144

THE recent publication of another work on *Chermes* by Prof. Cholodkovsky¹ affords an opportunity of laying before English readers a list of the different species of this genus known to this author as occurring in Europe, together with a critical examination of their specific characters. Cholodkovsky is well known as the recognized authority on this difficult genus of *Aphidae*, and his claims to be so regarded rest on no slender basis. Much of the substantial progress

¹ Der Coniferen-Läuse *Chermes*, Feinde der Nadelholzer. By Prof. N. Cholodkovsky. Friedländer and Sohn, Berlin, 1907.

made in our knowledge of these insects is due to the patience and perseverance with which he has devoted himself to their study ever since the discovery by Blochmann, some twenty years ago, of the existence of a sexual generation. His name is associated with those of Blochmann and Dreyfus as the three who discovered, independently of each other, the periodic migration of one generation from the Spruce to the Larch, and the re-migration of a subsequent generation the following year to the primary host plant. It was found that this migratory habit is closely connected with the production of the sexual generation, which never arises unless migration has previously taken place, since it is always from the eggs laid by the re-migrants, or Sexuparae as they are called, that the males and females hatch. Migration was at first regarded as a habit necessary for the existence of all species of *Chermes*, but it was soon shown that the insects are frequently found in woods where no Larches exist, or even in woods where the Spruce has no other Conifers near it to serve as intermediate host. Cholodkovsky and others then set to work to find out what happened in these cases, and in course of time it was ascertained that while in some cases various species of Pine and Silver Fir (*Abies*) served as intermediate host as well as the Larch, in other cases the migratory habit is either partly or entirely absent, and the insects then increase and multiply solely by parthenogenetic reproduction.

As the result of the researches undertaken to solve this problem, several new *Chermes* species have been added to the list, and Cholodkovsky recognizes no less than eleven different species in Europe alone. One or two of these have been insufficiently examined, and are therefore doubtful, but he regards the rest as well established. In this latest publication some thirty pages are devoted to describing these various species, each being dealt with at some length.

Most of the information given has appeared in his earlier and more detailed "Beiträge,"¹ and the book appears to have been written chiefly for the general reader, but it is however very useful as a supplement to the other, since it brings our knowledge of the various species up to date. Whilst the method adopted by the author in arranging the mass of information acquired, results in the presentation of an easily read descriptive history, it is not a very convenient arrangement for the entomologist who wishes to compare different species or examine their claims to specific rank. In the majority of cases the description of one species is a replica of that for the previous species, with minute variations of detail, and a search for the precise specific differences

¹Beiträge zu einer Monographie der Coniferen-Läuse. Der Gattung Chermes. By Prof. N. Cholodkovsky. Horae Soc. Ent. Ross., xxx, pp. 1-102 and xxxi, pp. 1-61.

becomes very wearisome. In the hope that entomologists in this country may be induced to turn their attention to this important genus, I have made a careful analysis of each species described by Cholodkovsky in this book, and arranged the results in as condensed a table as possible. In order to avoid needless repetition, I have also drawn up a table briefly detailing the chief generic characters, together with an outline of the habits of each generation. In these tables the months placed after each generation indicate the time of year when it is found, but these are of course only approximate, since the insects are influenced by the prevailing conditions of the weather in quite as great a degree as the trees on which they live. The letters P.H. and I.H. indicate the host, primary or intermediate, on which that particular generation is to be found, and the names of the trees serving as hosts will be found at the top of each page after the name of the insect.

THE GENUS

HABITS OF EACH GENERATION SUMMARISED.

I. **Fundatrices** :—August to following May. Larvae hibernate on or near the buds of the Spruce, attached by the long proboscis which is sunk in the tissues of the plant. In spring, without changing their position, they begin to suck, reach maturity in 3 to 4 weeks after undergoing 3 moults, lay a large heap of eggs and then die. The bud attacked becomes swollen and stunted in growth, being either partially or completely modified into a gall which resembles a miniature cone or pine-apple. The needles become swollen into 3 cornered scale-like structures which coalesce at their margins and form chambers in which the larvae of Gen. II. live.

II. **Alatae** :—May to July or August. Larvae inhabit the chambers of the gall; the nymphs creep out of the ripe gall and undergo their last (4th) moult on the adjacent needles; habits of adults vary—either they remain on the needles of the same tree or fly to other neighbouring Spruces, or they may migrate to another species of Conifer.

The **Non-migrants** give rise to
I. **Fundatrices**
and the cycle begins again.

V. The **Migrants** give rise to
further generations on the I.H.

III. **Colonici** :—August to following April or May. The larvae hibernate on the I.H., usually on the stems, occasionally on the needles. Their habits resemble those of the Fundatrices, but they cause no development of gall-growth on the I.H.

IV. **Exsules and / or Sexuparae** :—May to June. The generation usually splits into 2 parallel series, wingless Exsules and winged Sexuparae. The larval stages of both are passed on the needles of the I.H.

Adult Exsules.

Remain on the needles of the I.H.,
and give rise to other.....

Adult Sexuparae.

Fly back to the Spruce and lay
their eggs on the needles.

Exsules, one or possibly more generations being produced during the summer. Finally, as autumn approaches, the insects withdraw from the needles to the stem to hibernate, and are identical with generation

V. **Sexuales** :—May to August. Feed on the Spruce needles below or near the bodies of the dead Sexuparae. Habits rather more active than previous generations. After copulation the female lays one comparatively large egg under the scales at the base of the shoot.

III. **Colonici.**

I. **Fundatrices.**

CHERMES.

GENERIC CHARACTERS.

- I. **Larvae** minute wingless scale-like (0.5 mm. long \times 0.1 mm. broad) becoming swollen ovoid bodies about $\frac{2}{3}$ mm. in length when adult. **Head** depressed below the body and without any distinct division between it and thorax. **Proboscis** more than double the length of the body, its proximal end enclosed in a sheath, carried when not employed in sucking in an 8-shaped loop below the abdomen. **Antennae** short, 3-jointed, the 3rd joint considerably the longest. **Eyes** simple, 2 groups of 3 ocelli. **Legs** very short. **Epidermis** dorsal surface with 6 longitudinal rows of glandular plates bearing "pores" and / or facets, from which wool-like threads of wax are excreted; plates more or less fused on head and thorax and to some extent on abdomen; after 1st moult plates replaced by flat or domed warts bearing facets. **Sex** parthenogenetic females. **Eggs** stalked, numerous, laid in a heap round the mother.
-
- II. **Larvae** with 3-jointed antennae and rather short proboscis. The longitudinal rows of glandular plates are absent, and there is no "wool" excreted. **Adults** winged, size very variable (2 to 2.5 mm. long \times 0.8 mm. broad). **Antennae** 5-jointed, or apparently so, the 3rd joint being very long and constricted at two points, thus dividing it into 3 segments. Each of the three terminal segments bears a distinct olfactory pit. **Proboscis** short. **Eyes**, both simple and facetted, are present. **Wings** transparent; anterior about 3 mm. long with a thick post-costa running nearly parallel to the costa and ending in a long pigmented stigma. Below the post-costa runs a fine long longitudinal nervure, from which 3 oblique secondary nervures are given off. Posterior wing shorter, with a minute hook for linking the wings in flight, a fine longitudinal nervure from which runs a Fold ("Falte") placed either at right angles or obliquely; the fold may be accompanied by a fine secondary nervure. **Sex** parthenogenetic females. **Eggs** stalked and few in number.
-
- III. Structure practically identical with that of the **Fundatrices**, the only variation being in the structure of the glandular plates of the epidermis.

IV. **Exsules.**

Structure very similar to that of the **Colonici** or **Fundatrices**.

Sexuparae.

Structure very similar to that of the **Alatae**.

V. **Sexuales**:—Very minute wingless insects about $\frac{1}{4}$ mm. long. **Eyes** simple (2 groups of 3 ocelli). **Proboscis** short. **Antennae** 3-jointed in larvae, 4-jointed in adults. **Legs** rather long. **Males** more slender and active than females.

SUMMARY OF CHOLODKOVSKY'S DESCRIPTION OF

Chermes viridis, Ratz.P.H. Spruce (*Picea excelsa*), etc.I.H. Larch (*Larix europaea*), etc.

- I. **Fundatrices**:—P.H., seated on the neck of a bud, causing gall in spring. **Gall** variable in size, average being that of a small walnut. **Gall needles** with short normal apices. **Shoot** usually continues to grow above the gall, but sometimes absent or limited to a tuft of needles. **Colour** dependent on light, but usually velvety green with purple, red hairs round chamber mouths. **Ripens** about July, turning brown when dead. **Insects** dark or light green. **Wool** short and frizzly in winter, much thicker in spring, but never very long. **Glandular Plates**, with a small central pore, surrounded by about 4 larger double contoured pores, these being replaced after 1st moult by 4 longitudinal rows of flat warts. **Eggs** green.
-
- II. **Alatae**:—Adults migrate to I.H. **Larvae** green yellow; **Nymphs** reddish with green wing sheaths; **Adults** yellow-red with head, upper thorax, antennae and legs grey. **Wool** scanty, excreted in 3 transverse rows (— — —) from glands on metathorax and 1st abdominal segments. **Antennae**, length of 3 terminal joints variable, usually about equal, but 4th may be shorter or longer than 3rd. **Wings**; anterior with light green post-costa, posterior with a transverse fold ("Querfalte") running at right angles to the longitudinal nervure. The fold may be accompanied by a short nervure. **Eggs** dark green, numerous.
-
- III. **Colonici**:—I.H., in crevices of the bark. **Insects** practically identical with the **Fundatrices**, but adults somewhat smaller (about 1 mm. long) with shorter wool and less of it, and with a shorter proboscis loop which does not reach the hinder end of abdomen. **Eggs** green.
-
- IV. **Sexuparae** only:—Adults re-migrate to P.H. **Insects**, all stages yellowish green. **Adults** practically identical with the **Alatae**, but much smaller (about 1 to 1½ mm. long), with very little wool. **Eggs** greenish yellow, about 10 in number.
-
- V. **Sexuales**:—**Larvae** yellowish. **Adults**; males greenish yellow, females sulphur yellow. **Fertilised egg** yellow, with scanty covering of wool.

SUMMARY OF CHOLODKOVSKY'S DESCRIPTION OF

Chermes abietis, Kalt. P.H. Spruce (*Picea excelsa*).
I.H. None; migration does not occur.

I. **Fundatrices**:—Habits as in *Ch. viridis*. **Galls** similar but distinctly smaller in size and later in ripening. **Open** about end July to August. **Insects** dirty yellow and more slender in shape, but otherwise identical with **Fundatrices** of *Ch. viridis*. **Eggs** light yellow.

II. **Alatae**:—Adults (non-migrantes) on needles of P.H. **Insects** yellow at every stage. **Adults** with head and upper thorax black. **Antennae**, 3rd joint always distinctly shorter than 4th. In other respects similar to corresponding generation of *Ch. viridis*, but usually somewhat smaller. **Eggs** light yellow.

Remaining generations absent, the cycle being confined to the alternation of the above two parthenogenetic generations.

N.B.—The above two species (*Ch. viridis*, Ratz., and *Ch. abietis*, Kalt.) were formerly classed together by Cholodkovsky and others under the name *Ch. abietis*, Linn., or were at most regarded as varieties of this species. After the discovery of periodic migration, Blochmann reported that the intermediate host for *Chermes abietis*, Linn., was the Larch, but as the insect was also known to occur in woods of Northern Europe where no Larches exist, it was supposed that in these districts some other tree must serve as intermediate host. From a series of breeding experiments, which were repeated for five years and always gave the same results, Cholodkovsky found that although the **Alatae** would lay their eggs on any of the four following trees—Larch, Pine, Silver Fir and Spruce—yet the larvae which hatched from these eggs on the first three of these trees invariably died. He then discovered that there were two kinds of insect, a green and a yellow, and that (as the former is of comparatively infrequent occurrence in the neighbourhood of St. Petersburg) all his experiments had been performed with the latter. On repeating the experiments with the green *Chermes*, Cholodkovsky found that the larvae arising from eggs laid on the Larch survived the winter and completed their development successfully. He therefore regards them as two distinct species. He explains the laying of eggs on the wrong tree as due to the abdomen being full of eggs which must be laid, rightly or wrongly, because the insect cannot hold them back, and will even lay them on a glass bell jar in default of anything better.

SUMMARY OF CHOLODKOVSKY'S DESCRIPTION OF

Chermes strobilobius, Kalt. P.H. Spruce (*Picea excelsa*) etc.
I.H. Larch (*Larix europaea*) etc.

- I. **Fundatrices**:—P.H., seated on the bud instead of below it. **Buds** attacked usually weak ones on thin poorly grown branches. **Gall** small about the size of a pea. **The whole shoot** usually converted into the gall, the needles without normal apices, and all growth stopped beyond the gall. **Shape and colour** very variable; usually pale green with a whitish wax bloom, and always paler than preceding species. Some larvae always found on the outside of the gall. **Ripens** very early, being open by about middle June. **Insects** black, turning greenish yellow or greenish brown in spring. **Wool**, in winter, long straight hairs like minute glass rods, in spring very long white strands of twisted threads. **Glandular Plates** with one well marked central double contoured pore, replaced after 1st moult by 6 rows of warts. **Eggs** yellow to greenish yellow.
-
- II. **Alatae**:—Larvae in or on galls of P.H., adults (migrantes) on needles of I.H. **Larvae** greenish brown to reddish; **Nymphs** reddish brown; **Adults** dark red. **Antennae**, 4th joint slightly longer than 3rd, and 5th longer than 4th. **Wings**, anterior with grey post-costa, and the fine longitudinal nervure runs off more obliquely from the post-costa than in the two preceding species, posterior with the fold and secondary nervure placed obliquely to the longitudinal nervure. **Eggs** yellowish red, greenish when older, about 20, without wool.
-
- III. **Colonici**:—I.H. on the needles during the summer, hibernating on the bark of the branches. **Larvae** greenish grey in summer, chocolate brown with a greasy appearance in spring. **Wool** absent, only a little white powder visible on the hinder end of abdomen. **Glandular Plates** as in Gen. 1, but pores much smaller and plates partially fused together on abdomen as well as on head and thorax; warts domed, each bearing 2 pores. **Proboscis** loop comparatively short. **Eggs** very numerous, greenish brown.
-
- IV. Parallel series, **Exsules** and **Sexuparae**:—Larvae and Exsules on needles of I.H., often causing them to bend at right angles, Sexuparae migrate to needles of P.H.
- | Exsules. | Sexuparae. |
|---|---|
| Larvae of both grey to brown or black, without any wool. | |
| Adults dark brown with 6 rows of faceted warts, and thickly covered with coarse strings of white wool. Eggs greenish brown. | Adults greenish brown very similar to the Alatae, but smaller and distinguished by a marginal row of faceted warts round the abdomen, and brownish white wool. Eggs , yellowish green (becoming males), reddish (becoming females). |
-
- V. **Sexuales**:—Needles of P.H. **Insects** resemble corresponding generation of *Ch. viridis* in shape, size and habits. **Colour**: males, dirty olive green; females, reddish yellow.

SUMMARY OF CHOLODKOVSKY'S DESCRIPTION OF

Chermes lapponicus, Chol.P.H. Spruce (*Picea* sp.).

I.H. none.

- I. **Fundatrices**:—P.H., seated on the buds like the last species, and causing similar galls, on the outside of which some of the larvae are also found. **Insects** only distinguished from *Ch. strobilobius*-Fundatrices by their larger size, rather lighter color, more copious excretion of wool, and the assumption of a reddish color towards the end of egg laying. **Eggs** dark green.

Cholodkovsky recognises 2 varieties.

(a) var. praecox, Chol.

Larvae when not sucking have a proboscis loop nearly reaching the end of the abdomen. **Galls** open early, about June.

(b) var. tardus, Dreyfus.

Larvae have a very long proboscis loop, quite reaching the end of abdomen. **Galls** open late, about end July or August.

- II. **Alatae**:—Larvae in or on the galls, adults (non-migrantes) on needles of the same tree.

(a) Praecox.

Adults practically identical with corresponding generation of *Ch. strobilobius*, the color being light red, the 4th joint of antennae slightly longer than 3rd and 5th longer than 4th. **Wings** identical; **Wool** absent; **Eggs** light red, only dusted with white powder.

(b) Tardus.

Adults differ from *praecox* in their average larger size, in 4th joint of antennae being slightly shorter than 3rd, and in possessing well developed wax glands. **Eggs** reddish, covered with much white wool.

There are no other generations, the cycle being confined to the alternation of the above two parthenogenetic generations.

SUMMARY OF CHOLODKOVSKY'S DESCRIPTION OF

Chermes coccineus, Chol.¹ P.H., Spruce (*Picea excelsa* and other sp.)
I.H., Silver Fir (*Abies sibirica*, &c.)

I. **Fundatrices**:—P.H., seated on the buds like *Ch. strobilobius*. Gall small, average size that of a pea or wild strawberry, closely resembling *Ch. strobilobius*-galls, but without the whitish wax bloom, and colour dull green. **Buds** always completely modified without any normal growth above the gall. **Opens** early, about first half June, turning black when dead. **Chamber walls** of dead galls rather thicker than in *Ch. strobilobius*. **Insects** black, later bluish brown. **Wool**, longitudinal rows of short thick bundles, the 2 median rows forming a dorsal crest, the marginal rows forming a halo round the body; thicker in spring but never sufficient to entirely conceal the insect. **Glandular Plates** divided by fine lines into irregular areas, all of which are covered with facets; each plate has usually one eccentric pore as well. **Eggs** reddish brown.

II. **Alatae**:—Larvae in galls of P.H., adults (migrantes) on needles of I.H. **Larvae** greyish brown, later reddish; **Nymphs** dark red. **Adults** reddish brown, very similar to *Ch. strobilobius-Alatae* with grey post-costa, but 5th joint of antennae is rather shorter than 4th, and both joints are nearly cylindrical in shape. **Wool** absent. **Eggs** numerous reddish yellow.

III. **Colonici**:—I.H. on the needles where they also hibernate. **Larvae** blackish, very similar to **Fundatrices**. **Wool** forms a similar dorsal crest and marginal fringe, but later it becomes thicker and adults are entirely concealed in a thick ball of coarse threads. **Glandular Plates** partially fused together on abdomen as well as on head and thorax; plates with similar irregular areas, but only a few of these areas bear facets, viz., those adjoining the middle line and the margin of the body. **Eggs** dark green.

IV. Parallel series, **Exsules and Sexuparae**. Larvae and adult Exsules on needles of I.H., Sexuparae migrate to needles of P.H.

Exsules.

Dark violet, very similar to the **Colonici** but with 6 longitudinal rows of thick wax hairs. At a later stage wool becomes thick as in previous generation. These give rise to a second, and perhaps a third generation during the summer, as in *Ch. strobilobius*, and finally in autumn to hibernating **Colonici**.

Sexuparae.

Lighter in color, reddish violet and without any wool, becoming nymphs after 3rd moult. **Adults** dark red, almost identical with the **Alatae**, but much smaller. **Eggs** few, (5/10) reddish yellow without wool.

V. **Sexuales**:—on needles of P.H. **Larvae** dark grey. **Adults**: males, violet black; females dark reddish brown to black. **Egg** reddish brown.

¹ This species must not be confused with Ratzeburg's *Ch. coccineus*, which Choldkovsky regards as identical with *Ch. strobilobius*, Kalt. The above species is, as far as Choldkovsky knows, confined to Russia and Ratzeburg's name being free he applied it to this species.

SUMMARY OF CHOLODKOVSKY'S DESCRIPTION OF

Chermes funitectus, Dreyfus.P.H. Spruce (*Picea* sp.).I.H. Silver Fir (*Abies* sp.).

- I. **Fundatrices**:—Galls on Spruce have only twice been found, and Fundatrices only seen by Dreyfus, who has never published any description. The galls closely resemble those of *Ch. coccineus*, and the insects, which are also very similar, are said to possess certain well-marked differences.
-
- II. **Alatae**:—Adults almost exactly identical with *Ch. coccineus-Alatae*, merely differing in the structure of the antennae. The 5th joint is longer than the 4th.
-
- III. **Colonici**:—On the needles of the I.H. The insects only differ from *Ch. coccineus-Colonici*, in having the glandular plates continued in 6 longitudinal rows to the end of the abdomen without any fusion. The distribution of the faceted areas along the middle and marginal lines is identically the same.
-

IV. Parallel series, **Exsules** and **Sexuparae**:—On the needles of the I.H.

Exsules.

Not described.

Sexuparae.

Adults almost exactly identical with those of *Ch. coccineus*, but 5th joint of antennae is longer than the 4th. They are said¹ to migrate to the Spruce and there to lay 7 to 12 eggs.

V. Sexuales:—Dark brown. Copulation has not been witnessed and the fertilised egg has not been found.

N.B.—The knowledge of this species is very incomplete. The generations on the I.H. were the first discovered, by Dreyfus, who described the Sexuparae in a private letter to Cholodkovsky. He also stated that the galls, which were of rare occurrence, closely resembled *Ch. coccineus*-galls, and that the **Fundatrices**, while very similar, differed from *Ch. coccineus-Fundatrices*, in certain details which, however, he did not specify. Dreyfus has never published any detailed account of the insect. Cholodkovsky is the only other observer who has seen the galls. He received some ripe galls from the Caucasus which were practically identical with *Ch. coccineus*-galls. There were no remains of the **Fundatrices** to be found, but as the **Alatae** obtained from them resembled the **Sexuparae** described by Dreyfus in the structure of the antennae, Cholodkovsky identified the galls as those of *Ch. funitectus*.

¹ Nüsslin described a species on the Silver Fir under the name *Ch. piceae, Ratz.*, which Cholodkovsky also identifies as *Ch. funitectus* on the same grounds. Nüsslin described the **Colonici**, **Exsules** and **Sexuparae**. He found the last migrated to the Spruce and he found the **Sexuales** larvae, but never succeeded in following them further, or in finding **Fundatrices** or galls on the Spruce.

SUMMARY OF CHOLODKOVSKY'S DESCRIPTION OF

Chermes sibiricus, Chol.P.H. Spruce (*Picea* sp.).I.H. *Pinus cembra*.

- I. **Fundatrices**:—P.H., seated on the stem a little distance below the bud. **Gall** more elongated and less swollen than in other species, the shoot being less affected. Only the bases of the needles are swollen and these do not as a rule fuse together to form definite gall chambers. **Shoot** usually galled on one side only which results in its becoming curved. When the larvae are seated nearer the bud the effect is more marked, the gall is thicker and chambers may be formed. **Colour** greenish yellow with red hairs on the swollen bases of the needles. **Shoot** continues to grow on normal side after death of gall. **Opens** earlier than all other species, viz., May, June. **Insects** chocolate brown, later dark yellowish brown. **Wool**, a ball-like mass, moderately long in spring. **Glandular Plates** divided into polygonal areas by fine black lines, each polygon with a well marked periphery inside the black line; each plate with one central pore. **Eggs** brownish yellow.
-
- II. **Alatae**:—Larvae on galled shoots of P.H., adults (migrantes) on needles of I.H. **Larvae** brown. **Adults** dark red, very similar to *Ch. strobilobius-Alatae*, with grey post-costa, but 3rd and 4th joints of antennae are top-shaped, the proximal end of the joint being the pointed one. **Eggs** reddish yellow without wool.
-
- III. **Colonici**:—I.H., hibernating on the bark. **Larvae** yellowish grey; **Adults** yellow or reddish or dark green. **Glandular Plates** or flat warts bear a variable number of facets which are more strongly developed on the head and thorax but less numerous at the hinder end of the abdomen. **Wool** richly developed. **Eggs** yellow.
-
- IV. Parallel series, **Exsules** and **Sexuparae**. Larvae and adult Exsules on needles of I.H., adult Sexuparae on needles of P.H.
- | Exsules. | Sexuparae. |
|--|---|
| Practically identical with the Colonici . | Practically identical with the Alatae but much smaller. Eggs reddish yellow, covered with wool. |
-
- V. **Sexuales**:—On needles of P.H., males and females both red.

THE
JOURNAL
OF
ECONOMIC BIOLOGY.

Edited by

WALTER E. COLLINGE, M.Sc., F.E.S.,

*Foreign Member of the Association of Economic Entomologists, Washington, U.S.A.;
Honorary Secretary of the Association of Economic Biologists; Honorary
Consulting Zoologist to the Land Agents' Society, and the Midland
Reafforesting Association; and Special Lecturer on Economic
Zoology in the University of Birmingham,*

With the co-operation of

Professor A. H. REGINALD BULLER, D.Sc., Ph.D.,
The University of Manitoba, Winnipeg.

Professor GEO. H. CARPENTER, B.Sc., M.R.I.A.,
The Royal College of Science, Dublin.

ROBERT NEWSTEAD, A.L.S., F.E.S.,
Liverpool School of Tropical Medicine.

AND

A. E. SHIPLEY, M.A., F.R.S.,
Christ's College, Cambridge.

The Journal will be issued at a prepaid annual subscription of 16/-, four parts to constitute a volume.

All business and literary communications should be addressed to the Editor.

All Subscriptions should be forwarded to the Publishers.

LONDON:
DULAU & Co.,
37, Soho Square, W.

**HOW TO FILL THE KIT
.. WITH ..
WHOLESOME MILK.**

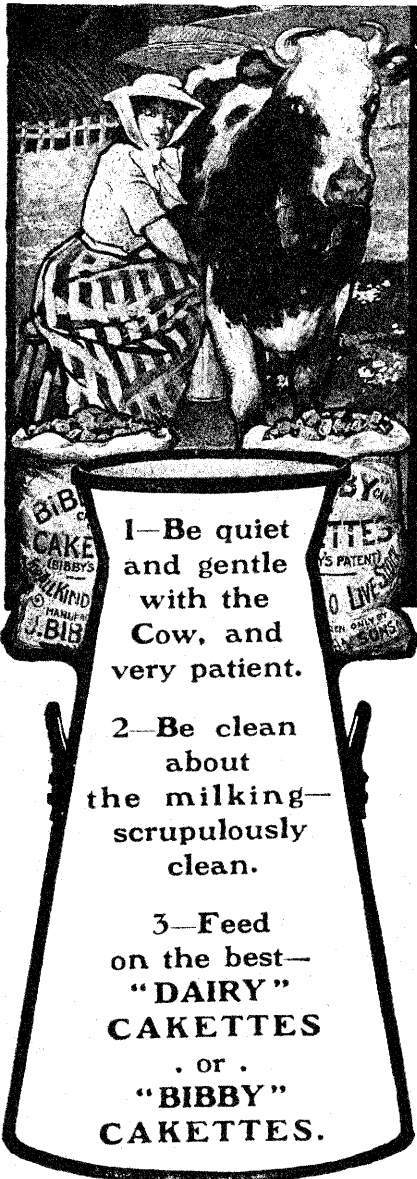

“Cakettes” may be had on application to our Local Representative,
or direct from the Sole Manufacturers,

J. BIBBY & SONS,

Exchange Chambers, LIVERPOOL.

HEARSON'S PATENT "CHAMPION" INCUBATORS.



During the years 1904-5 Hearson's Incubators were tested at the University College, Reading, with other machines, the result being that Hearson's Incubators hatched the highest percentage of eggs recorded. Such an impartial testimony is conclusive proof of the superiority of these machines.

HEARSON'S FOSTER MOTHER

(The "Hydrothermic")

For Outdoor Rearing of Chickens in Winter or Summer.

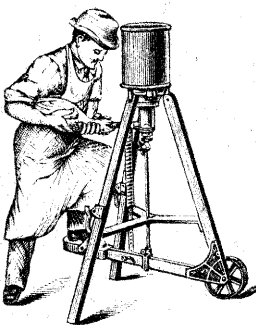
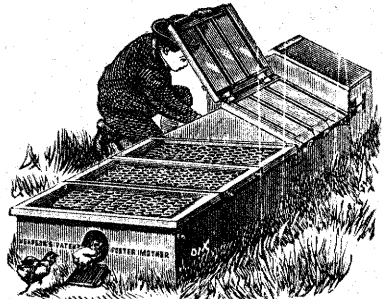

HEARSON'S PATENT CRAMMING . . MACHINE

For the Forced Feeding of Fowls, Turkeys, etc.

Show Rooms: 235, Regent Street, London, W.

Write for Illustrated Catalogue.

Sole Agents—

SPRATT'S PATENT, LTD.,

24 & 25, Fenchurch Street, London, E.C.

SILCOCK'S FATTENING CAKE

(MADE SPECIALLY FOR FATTENING PURPOSES)



**YIELDS
BETTER
RESULTS
THAN**



ENGLISH LINSEED CAKE.

We have made this claim for twelve years, and each year it has been more thoroughly established and confirmed by thousands of farmers. **YOU MAY DOUBT**, but test it for yourself, as many others have done; you will make money by the experiment—we will gain a customer. It is guaranteed by analysis and practical feeding tests. We make one cake do one thing well. One cake for all purposes means waste and inefficiency.

READ THIS!

Mr. HERBERT LAKE, CREDITON, DEVON, writes September 4th, 1905:—

"I was a great believer in Linseed until I proved that your Fattening Cake is much superior. As a test, I fed one lot of steers exclusively on your Cake, and another lot on English Linseed (weight for weight), and I was very much surprised to find that the result gave a much greater weight of beef in favour of the Fattening Cake. I can thoroughly recommend your Cake to every farmer as the best (including Linseed) that can be used. Please send me two more tons, ex contract, at your earliest."

We respectfully solicit a trial order.

**OUR MANUFACTURES INCLUDE FATTENING, REARING, DAIRY, AND
UNIVERSAL CAKES AND MEALS, COTTON CAKES,
SOLUBLE CALF MEAL, Etc.**

For particulars, apply to local agent, S. CARE, Stechford, Birmingham.
C. HULL, Solihull, Birmingham, or

**R. SILCOCK & SONS, STANLEY HALL,
UNION STREET, LIVERPOOL.**

THE
JOURNAL
OF
ECONOMIC BIOLOGY.

Edited by

WALTER E. COLLINGE, M.Sc., F.E.S.,

*Foreign Member of the Association of Economic Entomologists, Washington, U.S.A.;
Honorary Secretary of the Association of Economic Biologists; Honorary
Consulting Zoologist to the Land Agents' Society, and the Midland
Reafforesting Association; and Special Lecturer on Economic
Zoology in the University of Birmingham,*

With the co-operation of

Professor A. H. REGINALD BULLER, D.Sc., Ph.D.,
The University of Manitoba, Winnipeg.

Professor GEO. H. CARPENTER, B.Sc., M.R.I.A.,
The Royal College of Science, Dublin.

ROBERT NEWSTEAD, A.L.S., F.E.S.,
Liverpool School of Tropical Medicine.

AND

A. E. SHIPLEY, M.A., F.R.S.,
Christ's College, Cambridge.

The Journal will be issued at a prepaid annual subscription of 16/-, four parts to constitute a volume.

All business and literary communications should be addressed to the Editor.

All Subscriptions should be forwarded to the Publishers.

LONDON:
DULAU & Co.,
37, Soho Square, W.

.. BIBBY'S ..
“CREAM EQUIVALENT.”

A Calf Meal which never disappoints.

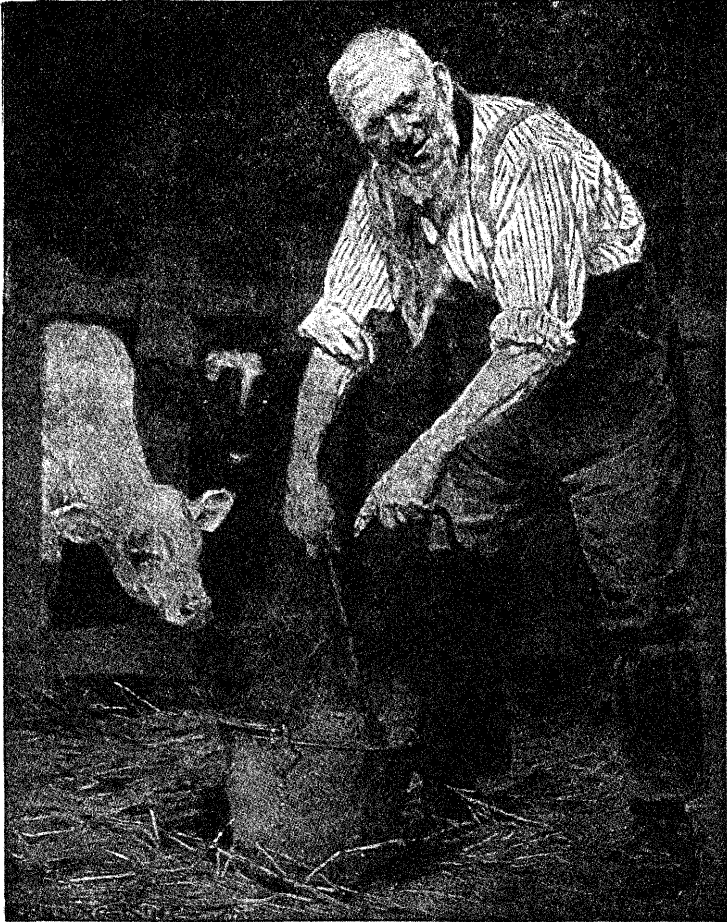

*“This ‘Cream Equivalent’ do smell beautiful,
I a’most wish I was a calf.”*

Our new circular, “How to rear Calves for the Dairy,” will be sent free to any applicant mentioning this journal.

SOLE MANUFACTURERS—

J. BIBBY & SONS,

Exchange Chambers, LIVERPOOL.

HEARSON'S PATENT "CHAMPION" INCUBATORS.



During the years 1904-5 Hearson's Incubators were tested at the University College, Reading, with other machines, the result being that Hearson's Incubators hatched the highest percentage of eggs recorded. Such an impartial testimony is conclusive proof of the superiority of these machines.

HEARSON'S FOSTER MOTHER

(The "Hydrothermic")

For Outdoor Rearing of Chickens in Winter or Summer.

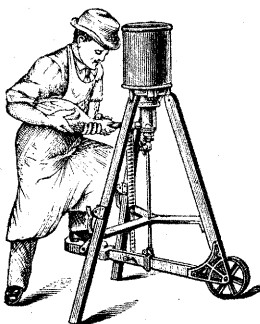
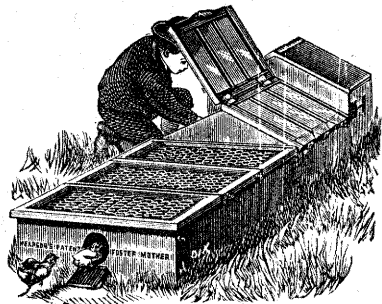

HEARSON'S PATENT CRAMMING . . . MACHINE

For the Forced Feeding of Fowls, Turkeys, etc.

Show Rooms: 235, Regent Street, London, W.

Sole Agents—

Write for Illustrated Catalogue,

SPRATT'S PATENT, LTD.,

24 & 25, Fenchurch Street, London, E.C.

Vol. 2.

December 11th, 1907.

No. 3.

THE
JOURNAL
OF
ECONOMIC BIOLOGY.

Edited by

WALTER E. COLLINGE, M.Sc., F.E.S.,

Foreign Member of the Association of Economic Entomologists, Washington, U.S.A.;
Honorary Secretary of the Association of Economic Biologists; Honorary
Consulting Zoologist to the Land Agents' Society, and the Midland
Reafforesting Association; and Special Lecturer on Economic
Zoology in the University of Birmingham,

With the co-operation of

Professor A. H. REGINALD BULLER, D.Sc., Ph.D.,
The University of Manitoba, Winnipeg.

Professor GEO. H. CARPENTER, B.Sc., M.R.I.A.,
The Royal College of Science, Dublin.

ROBERT NEWSTEAD, A.L.S., F.E.S.,
Liverpool School of Tropical Medicine.

AND

A. E. SHIPLEY, M.A., F.R.S.,
Christ's College, Cambridge.

The Journal will be issued at a prepaid annual subscription of 16/-, four parts to constitute a volume.

All business and literary communications should be addressed to the Editor.

All Subscriptions should be forwarded to the Publishers.

LONDON:
DULAU & Co.,
37, Soho Square, W.

. . . BIBBY'S . . .
“CREAM EQUIVALENT.”

A Calf Meal which never disappoints.

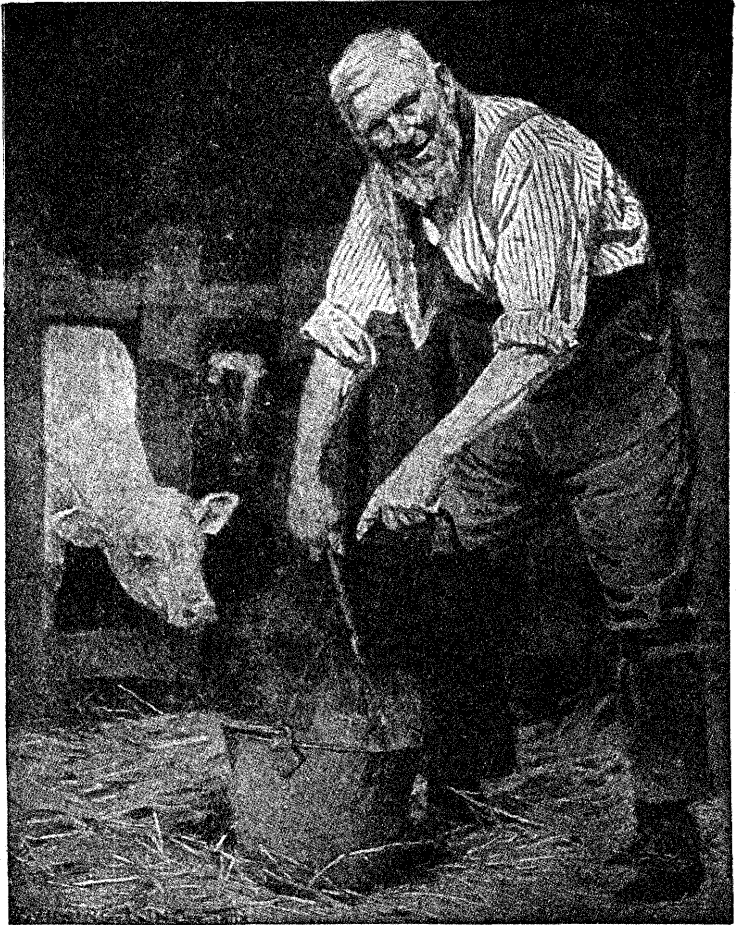

*“This ‘Cream Equivalent’ do smell beautiful.
I a'most wish I was a calf.”*

Our new circular, “How to rear Calves for the Dairy,” will be sent free to any applicant mentioning this journal.

SOLE MANUFACTURERS—

J. BIBBY & SONS,
Exchange Chambers, LIVERPOOL.

SECOND-HAND BOOKS
AT HALF PRICES !!

NEW BOOKS AT 25 % DISCOUNT!

Books on Biological, Scientific, Botanical,
and other subjects, and for ALL
Examinations supplied. Sent on approval.

State Wants, Catalogues free.

BOOKS BOUGHT—GOOD PRICES GIVEN.

S. A. FOYLE, 135, CHARING CROSS ROAD,
LONDON, W.C.

BAYLISS,

JONES and BAYLISS, LIMITED.

— Manufacturers of —

IRON & WIRE FENCING, RAILING, GATES, &c.

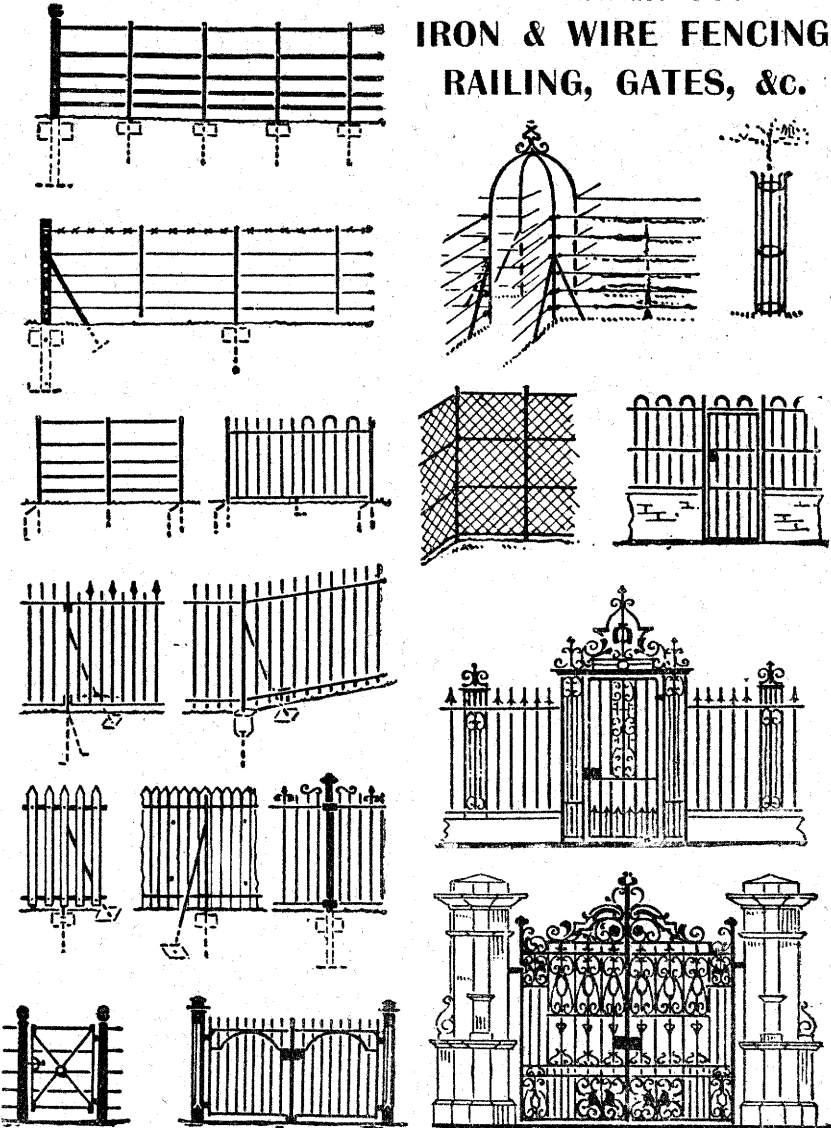

Illustrated Catalogue Free.

WOLVERHAMPTON,

And 139 & 141, CANNON STREET, LONDON, E.C.

Vol. 2.

February 21st, 1908.

No. 4.

THE
JOURNAL
OF
ECONOMIC BIOLOGY.

Edited by

WALTER E. COLLINGE, M.Sc., F.E.S.,

*Foreign Member of the Association of Economic Entomologists, Washington, U.S.A.;
Honorary Secretary of the Association of Economic Biologists; Honorary
Consulting Zoologist to the Land Agents' Society, and the Midland
Reafforesting Association; and Special Lecturer on Economic
Zoology in the University of Birmingham,*

With the co-operation of

Professor A. H. REGINALD BULLER, D.Sc., Ph.D.,
The University of Manitoba, Winnipeg.

Professor GEO. H. CARPENTER, B.Sc., M.R.I.A.,
The Royal College of Science, Dublin.

ROBERT NEWSTEAD, A.L.S., F.E.S.,
Liverpool School of Tropical Medicine.

AND

A. E. SHIPLEY, M.A., F.R.S.,
Christ's College, Cambridge.

The Journal will be issued at a prepaid annual subscription of 16/-, four parts to constitute a volume.

All business and literary communications should be addressed to the Editor.

All Subscriptions should be forwarded to the Publishers.

LONDON:
DULAU & Co.,
37, Soho Square, W.

.. BIBBY'S ..
"CREAM EQUIVALENT."

A Calf Meal which never disappoints.

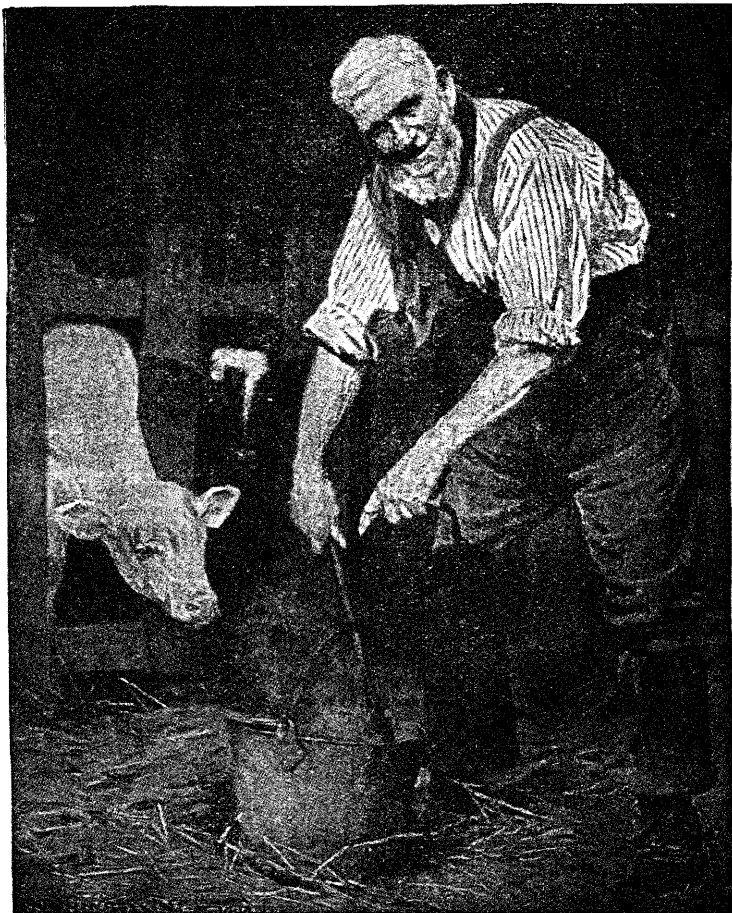

*"This 'Cream Equivalent' do smell beautiful.
I a'most wish I was a calf."*

Our new circular, "How to rear Calves for the Dairy," will be sent free to any applicant mentioning this journal.

SOLE MANUFACTURERS—

J. BIBBY & SONS,
Exchange Chambers, LIVERPOOL.

Agricultural & Garden Requisites

WRITE FOR 1908 LIST.

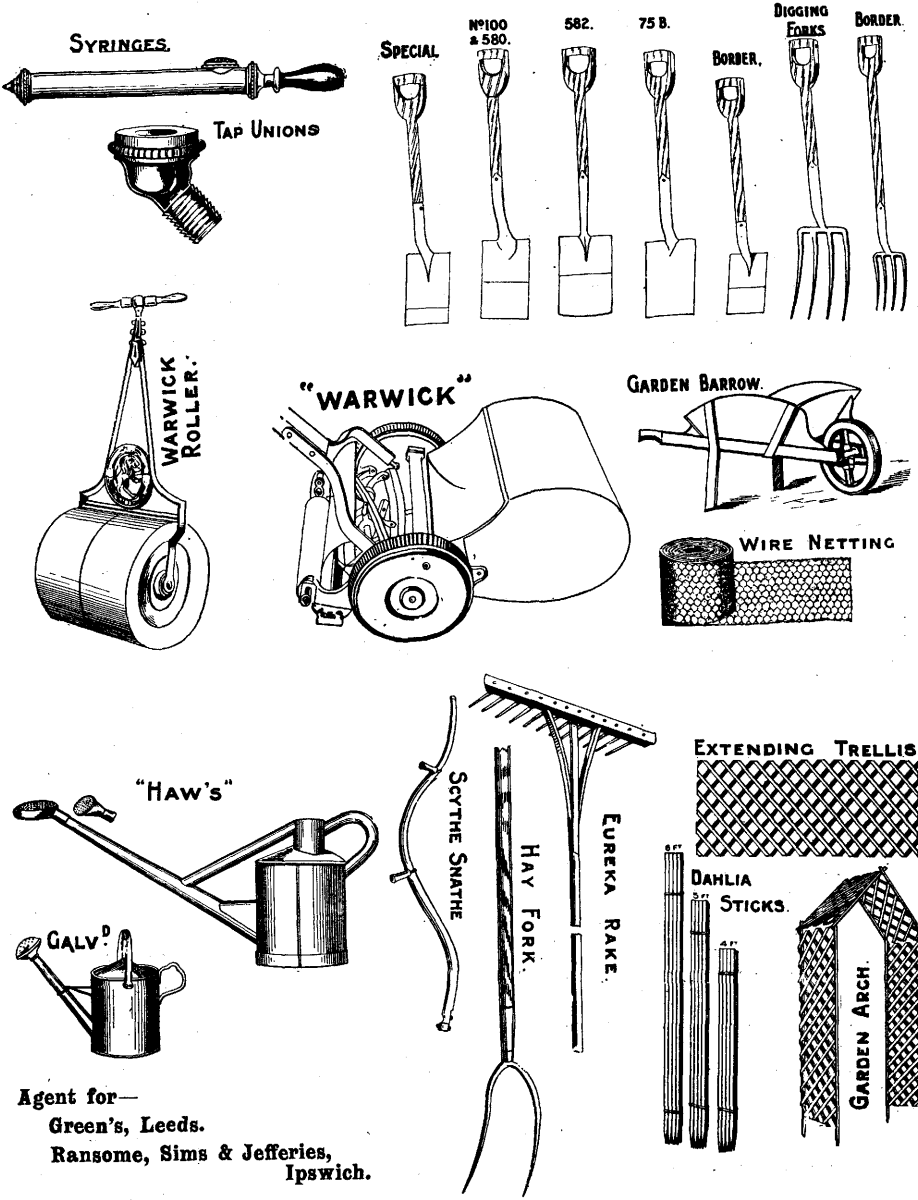

Agent for—
 Green's, Leeds.
 Ransome, Sims & Jefferies,
 Ipswich.

DIRECT FROM

**C. H. BALDWIN, 6 & 8, Lancaster Street,
 BIRMINGHAM.**

Telephone
 1737.

Life-Histories of Injurious Insects

IN CASES GLAZED BOTH SIDES, 6 x 6.

As Supplied to

West of Scotland, Harper Adams, Aspatria, Albert (Dublin), and other Agricultural Colleges, and to various Educational Committees.

A LIFE-HISTORY WILL BE SENT ON APPROVAL FOR INSPECTION, ALSO A LIST OF FIFTY CASES.

JOHN DAVIS (Successor to THOMAS LAURIE),
13, PATERNOSTER ROW, LONDON.

BUSINESS SYSTEMS

AND

UP-TO-DATE METHODS

Are our Speciality.

We help you

TO KEEP ALL RECORD

IN PERFECT ORDER,

And Mechanical Accurate

With a Minimum of Labour.

LET US EXPLAIN OUR

IDEAS TO YOU.

It will cost you nothing and may save Hours of Labour.

Our Representative will be pleased to give you a call

And give you the Benefit of our Experience.

OFFICE AND FACTORY ORGANIZATION.

THE CARD SYSTEM

IS THE BEST, QUICKEST,

And most Economical Method OF KEEPING RECORDS.

Professional Gentlemen,

Libraries, Hospitals,

Museums, Art Galleries,

Manufacturers,

USE OUR SYSTEMS.

CALL AT OUR SHOWROOMS OR SEND FOR CATALOGUE TO

LIBRARY BUREAU

LTD.,

78, NEW STREET,

BIRMINGHAM.

(Opposite General Post Office.)

Please mention this Paper.

SOUTHALL BROS. & BARCLAY

LIMITED,

“Central Depot,”
1, Broad Street, BIRMINGHAM.

WHERE MAY BE HAD
Chemical, Physical, and
General Scientific Apparatus
AND
PURE CHEMICALS.

CAMERAS, LENSES,
AND
ALL PHOTOGRAPHIC SUNDRIES.

Contractors to . . .

THE BIRMINGHAM UNIVERSITY,
THE BIRMINGHAM MUNICIPAL TECHNICAL SCHOOL,
etc., etc.

Telegraphic Address:

“SOUTHALL, BIRMINGHAM.”

Telephone No. 3268

Catalogues post free on application.

NOW READY. PRICE 7/6 NET.

349 pp., demy 8vo, green cloth, gilt lettering, illustrated with 24 Collotype plates reproducing 186 specimen sections of various soft and hard woods used in all kinds of wood-consuming industries and handicrafts, three times natural size, prepared by ARTHUR DEANE.

THE
“TIMBERS OF COMMERCE AND THEIR IDENTIFICATION.”

By **HERBERT STONE, F.L.S., F.R.C.I.**

Scale, three times natural size (9 to a Page).

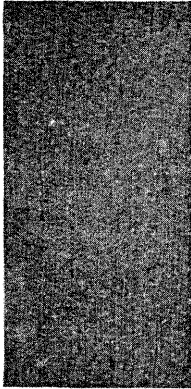

Fig. 112.
Brosimum (Letter-wood).

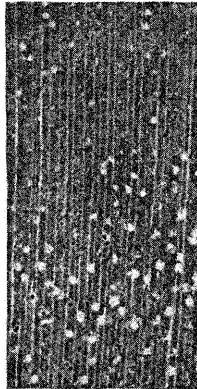

Fig. 113.
Artocarpus (Jak-tree).

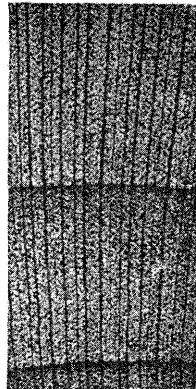

Fig. 114.
Platanus occidentalis
(Western Plane-tree).

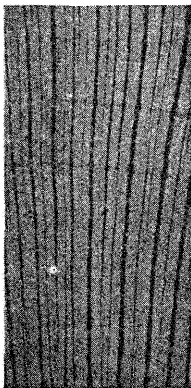

Fig. 115.
Platanus orientalis
(European Plane-tree).

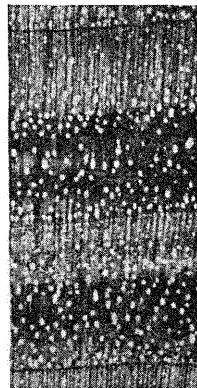

Fig. 116.
Juglans (Walnut).

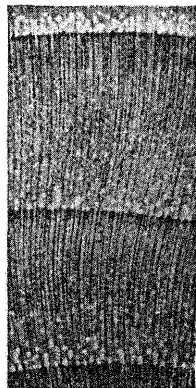

Fig. 117
Carya (Hickory).

OPINIONS OF THE PRESS.

Nature:—"The information contained in its pages is such that only an enthusiast and expert could bring together The author seems to have spared no pains in collecting and authenticating the vast amount of information and details."

The Journal of Botany:—"It needs only a glance at its contents to show that Mr. Stone's knowledge of the subject, both scientifically and commercially, is as great as his interest in its study."

The Pharmaceutical Journal:—"There is no other work in the language which covers the same ground . . . ought to be placed in every Reference and Free Library in the Kingdom."

De Indische Mercur:—"Voor hen, die met exotische Houtsoorten te doen hebben, zal het werd van Herbert Stone een zeer welkom boek voor het naslaan zijn."

Le Mercure de Belg'que:—"Le bel ouvrage de M. H. Stone . . . dans son genre il est des plus complets, si pas le plus complet, qui ait été publié."

W. RIDER & SON,
164, Aldersgate Street, London.

Scientific Instruments

OF ALL DESCRIPTIONS

FOR

DEMONSTRATION and EXPERIMENTAL
WORK IN THE SCIENCES.

- CHEMISTRY.
- BACTERIOLOGY.
- BOTANY.
- GEOLOGY.
- MINERALOGY.
- METALLURGY.
- ETC.

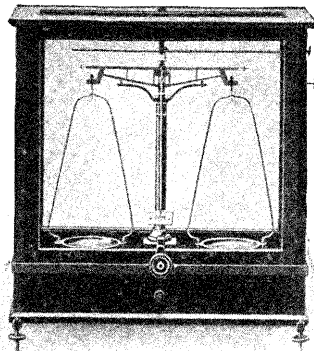

- PHYSICS.
- MAGNETISM.
- ELECTRICITY.
- SOUND.
- LIGHT.
- HEAT.
- ETC.

REFINED CHEMICALS AND PURE ACIDS FOR ANALYSIS.

All Instruments held in stock. Orders promptly executed.

LABORATORY FURNISHING IN ITS ENTIRETY.

*Inspection of
Show Rooms
invited.*

BALANCES & WEIGHTS
a speciality.

*Catalogues
Free
on application.*

PHILIP HARRIS & CO., Ltd.,
Instrument & Laboratory Specialists,
144-146, EDMUND STREET,
BIRMINGHAM.

Perfect Development of Plants

CAN ONLY BE OBTAINED BY PERFECT FEEDING.

Plant life, like animal life, develops by the assimilation of food. If insufficiently nourished the plant, like the body, will become impoverished and debilitated, but if well fed Perfect Development is the result.

FERTILO (Harvey's Universal Fertilizer)

is essentially a plant food. It imparts to the soil those exact properties upon which the plant thrives; it will build up the tissues and ensure robust and sturdy growth to any form of vegetable life.

(Write for copies of Testimonials, etc.)

THE BEST VALUE FOR MONEY OBTAINABLE IN FERTILIZERS.

NOTE ITS INEXPENSIVENESS—

7 lb. **2/-**, 14 lb. **3/-**, 28 lb. **4/6**, 86 lb. **8/-**, 1 cwt. **15/-** (all carriage paid).

Sole Manufacturers—

J. P. HARVEY & Co.,

KIDDERMINSTER.

Obtainable of Seedsmen and Florists or direct from the Makers.

JAMES SWIFT & SON,

Manufacturing Opticians.

Seven Gold Medals awarded for Optical Excellence.

This Microscope is used by the principal Bacteriologists and Medical Officers throughout the Country.

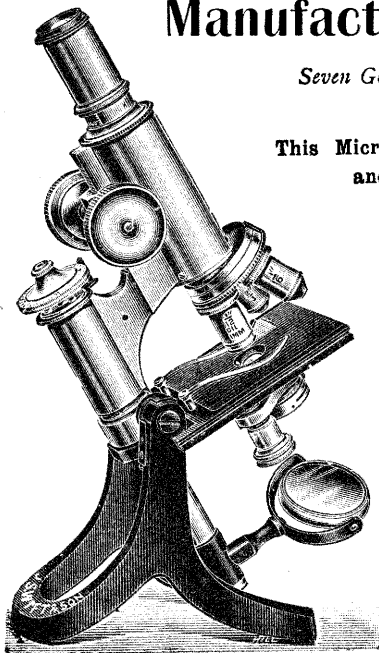

Professor Delepine's Bacteriological Microscope as used in the Birmingham University, fitted with coarse adjustment, patented slow adjustment for fine focussing, extra large stage covered with vulcanite, $\frac{3}{8}$ -in., $\frac{1}{2}$ -in. and $\frac{1}{2}$ -in. oil immersion lens, Panaplanatic Series, Abbe Condenser with iris diaphragm and focussing adjustment, triple dustproof nose-piece and eyepiece, in Cabinet. £15 0 0

**UNIVERSITY OPTICAL WORKS,
81, Tottenham Court Road,
LONDON, W.**

W. WATSON & SONS, 2, Easy Row, BIRMINGHAM.

NEW HIGH-POWER PORTABLE MICROSCOPE.

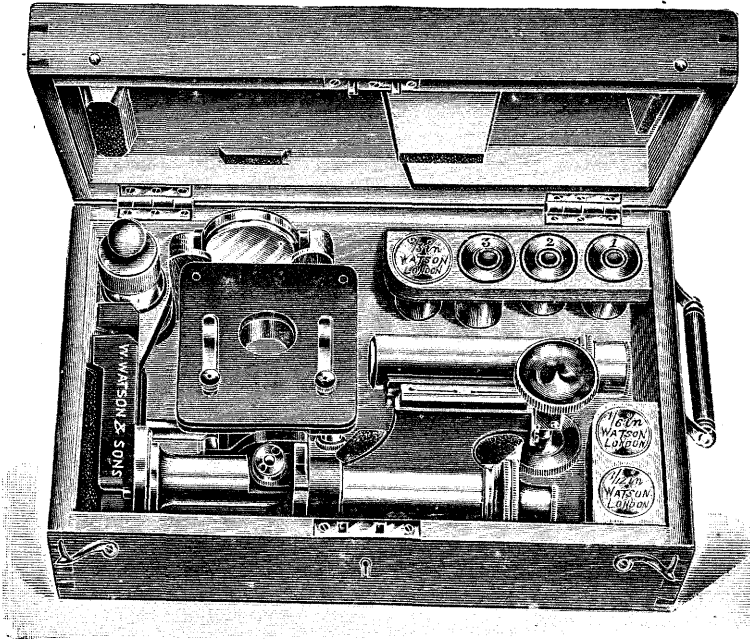

Weight,
8 lbs. 13 ozs.
Size of Case,
 $11\frac{3}{4} \times 7\frac{3}{8}$
 $\times 4\frac{1}{4}$ ins.



PERFECT RIGIDITY. SUITABLE for the HIGHEST POWER WORK with OIL IMMERSION LENSES.



Particulars free by post.

LANTERN SLIDES 6/- PER DOZ.

In all branches of Natural History; 20,000 in stock. Catalogues free. Lantern Slides prepared to order from negatives, illustrations, etc., at special low rates.

HAND-PAINTED LANTERN SLIDES from 1/6 to 5/- each.

STORAGE CABINETS FOR LANTERN SLIDES—new introduction—all sizes—see leaflet.

MICROSCOPICAL SLIDES

in Botany, Zoology, Entomology, &c., from 6/- doz.

See new and enlarged Catalogue.

Microscopes, Mounting Requisites, Pocket Lenses, and all Nature-Study Appliances.

Optical Lanterns and Accessories. Photographic Outfits.

**FLATTERS & GARNETT, LTD.,
48, DEANSGATE, MANCHESTER.**

LABORATORIES—CHURCH ROAD, LONGSIGHT.

Preparers of Lantern and Microscopical Slides to the principal Universities and Technical Schools, to the Crown Agents for the Colonies, &c.



COOPER'S DIP

HAS NEVER BEEN
EQUALLED.

CURES AND
KEEPS CURED.

UNIFORM IN STRENGTH AND QUALITY.

Does all that any other dip will do, and in addition

BENEFITS THE WOOL

And makes a HEAVIER FLEECE.

ALWAYS RELIABLE AND
ALWAYS REPAYS ITS COST.

AGENTS EVERYWHERE.

Sole Manufacturers, Wm. COOPER & NEPHEWS, Berkhamsted.

SCIENTIFIC APPARATUS

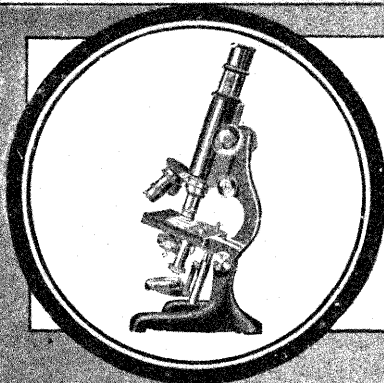

MICROSCOPES

and Accessories of every description.

The illustration represents LEITZ STAND F inclinable, with arched limb.

This Stand embodies in a very high degree all the most recent practical improvements, whilst its cost is remarkably low.

PURE ACIDS

Of guaranteed Purity. Made at our own works. Supplied to the leading Scientific Institutions and Works throughout the Kingdom.

BALANCES

Of the finest workmanship, fitted with our Regd. Beam. In this invention the Agate Knife Edges are so fitted that in case of damage they can be replaced in a few seconds.

GLASS WARE.

Complete range of Glass Apparatus kept in stock and supplied at the shortest notice.

SILICA WARE.

Choice Selection of the New Fused Quartz Apparatus.

Silica Ware has many properties which render it an invaluable adjunct in the Laboratory. It can be heated in the blowpipe and plunged into cold water without cracking, and for many purposes replaces Platinum.

GRADUATED INSTRUMENTS.

Every variety of instrument supplied, accurately adjusted.

PORCELAIN.

Genuine Royal Berlin, and best make second quality in stock.

CHEMICALS.

Kahlbaum's and Merck's in stock.

**Sulphur, Lime,
Sulphate of Copper,
Quassia, etc.**



Telephone—3825 Central.

Telegrams—
"Laboratory," Birmingham.

FULL CATALOGUES POST FREE

STANDLEY BELCHER & MASON LTD
LUDCATE HILL
BIRMINGHAM.

Horticultural Requisites.

“GISHURST COMPOUND”

For preventing and destroying **Red Spider, Green Fly, &c.** Harmless in use. Its soluble sulphur, &c., has for 40 years cured **blights and fungus** on plants. It is also useful for washing unhealthy dogs.

“GISHURSTINE”

For the protection of **Boots and Shoes** from damp, ensuring comfort and health to the wearers. Boots treated with Gishurstine take polish. It is also good for use on harness.

SOFT SOAP

Specially prepared as an insecticide, including

“SOFT SOAP and Quassia.” “SOFT SOAP and Paraffin.”

To be obtained from all dealers in Horticultural Requisites, or Wholesale from

PRICE'S PATENT CANDLE COMPANY LIMITED,
LONDON, LIVERPOOL and MANCHESTER.

To Fruit Growers, Horticulturists, &c.



THE **'MACKENZIE'** **SPRAY.**

An absolutely reliable portable Spray. Can be used with 1, 2 or 3 nozzles, and the tubing connected with the handle can be lengthened by screwing on the additional tube rods supplied.

A pump; C rubber tubing; D brass tube with wooden handle at one end and Spraying Nozzle at other end; E pump supports, pivoted for folding up. The iron vessel for spray fluid is shown in dotted lines.

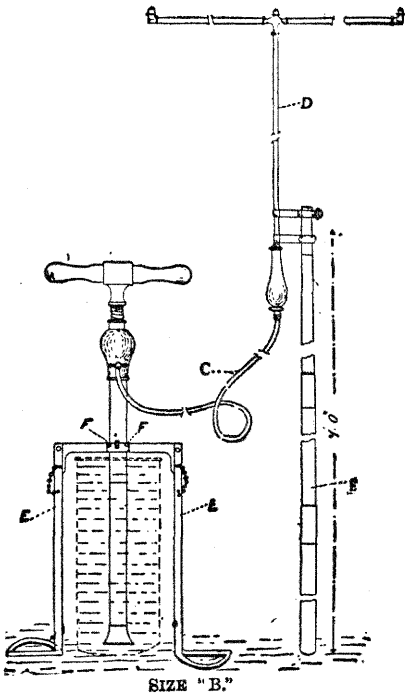

Price of Sprays—

SIZE A.—For ordinary work, with Cross Piece and Two Nozzles, additional rods and rubber tubing - **£2-2-0**

SIZE B.—With Cross Piece and Three Nozzles, Lengthening Rods and Rubber Tubing - - **£3-3-0**

Special made Iron Vessel for Spray fluid, **7/-**

To be obtained only from—

The Thresh Disinfecter Co., Ltd.,
16, GT. GEORGE STREET,
WESTMINSTER, LONDON, S.W.

DESTROY CHARLOCK

(Yellow Weed
Kedlock, Wild
Mustard, Milk,
etc., etc., etc.)

In growing Crops of Corn, Peas, Beans, Clover, Grass, etc.

16 to 20 bushels extra corn per acre.

Great improvement in quality of corn, owing to full benefit of manure and mould and moisture. Absence of Charlock checks the flea beetle and the club root.

Improvement of land (Charlock almost poisons the soil).

Spraying is ABSOLUTELY CERTAIN. It kills the Charlock both in and between the drills.

A Sprayer does 12 to 30 acres daily (compare hoeing half-acre daily).

Hoeing kills Charlock only between drills, and with hand pulling is very expensive.

Ploughing up all the crop, or turning on the sheep, is a pitiful waste.

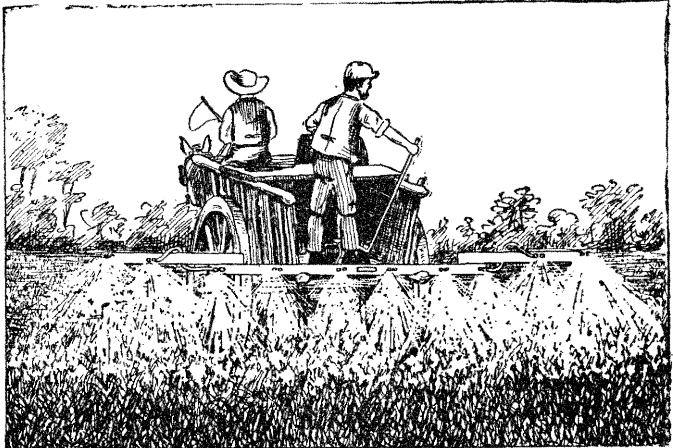

No. 1. To spray from 12 acres daily (8 nozzles) - £6-15-0
 No. 2. " " " (12 ") - £8-15-0

A colossal success awaited the Charlock Spraying Process (originally by Strawsons in 1898). Huge Sales in all parts of the world have been made. There is a heavy money profit in the process. Farmers should write for Booklets, Farmers' Testimonials, College Reports, etc., etc.

STRAWSONS' SPRAYERS.

Sulphate of Copper (Charlock Brand), specially prepared for Charlock Spraying, 98% pure. The only brand of the kind which is immediately soluble in cold water. Beware, especially of ordinary ground sulphates, which are quite unlike Charlock Brand. Ask for Booklet 5a (New Edition.)

SPRAYERS FOR WINTER SPRAYING.

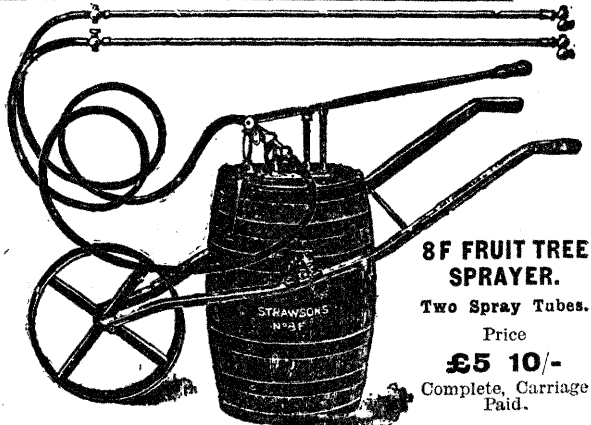

8F FRUIT TREE SPRAYER.

Two Spray Tubes.

Price

£5 10/-

Complete, Carriage Paid.

It pays up-to-date growers to Spray their Fruit Trees, for a sound crop commands a ready sale, and makes a good price.

USE STRAWSONS' REALLY PRACTICAL SPRAYERS.

The old way (infected Trees and unsound Fruit) does not pay.

Write for Catalogue of our various Machines.

Repairs Promptly Executed. All Duplicate Parts supplied from Stock.

MACKIES LIMITED, Caversham ROAD, READING.

PHIPPS' PERFECTION HOT WATER TANK INCUBATORS.

*Winner of 35
Gold and Silver
Medals.*

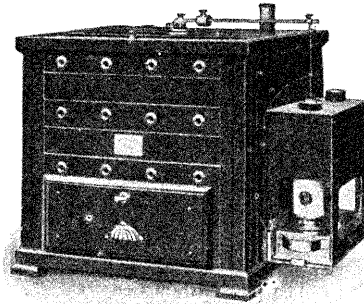

*Highest Honours
wherever
Exhibited.*

PRICE AND CAPACITY—

30 Egg	- -	£2 12s. 6d.	100 Egg	- -	£4 0s. 0d.
60 Egg	- -	£3 7s. 6d.	200 Egg	- -	£6 17s. 6d.

THIS Incubator is universally acknowledged to be the finest machine of its kind manufactured. It possesses many distinct advantages over any known machine; it is constructed throughout of the very best materials obtainable; the principle and arrangement is of the most approved type; and the simplicity of working is such that any person gifted with ordinary intelligence would experience no difficulty whatever in regulating the heat to the required temperature.

PHIPPS' ^{GOLD MEDAL} HOT AIR TANK FOSTER MOTHER.

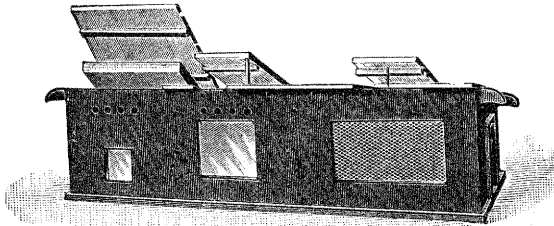

THE one and only successful rearer, combining perfect ventilation without draught, and absolute freedom from lamp fumes in the sleeping chamber. The original Three Compartment Foster Mother, and the only machine constructed with three distinct compartments of graduated heat.

Made in Three Sizes, as follows—

60 Chick capacity	- -	£2 13s. 0d.
100 " "	- -	£3 3s. 0d.
150 " "	- -	£4 4s. 0d.

SOIL INSECTS

SUCH AS

WIREWORM, WOODLICE, LEATHER JACKETS,
SLUGS, GRUBS, ANTS, BEETLES, JULUS WORMS,
EELWORMS, CENTIPEDES, etc., etc., are destroyed
by using

VAPORITE.

VAPORITE worked into the soil as directed completely destroys the soil insects without the slightest injury to the plants. It is non-poisonous and no special implements are required.

When VAPORITE lies in the damp soil it gives off a vapor which suffocates the insects and thus completely cleans the soil of these pests.

VAPORITE is we believe absolutely the first material ever discovered which deals practicably with soil insects. Its use, therefore, is almost revolutionary in some branches of Horticulture.

Price—56 lbs., 6/6; 112 lbs., 10/-; £9 per ton.

STRAWSONITE

Improved Concentrated Bordeaux Mixture, guaranteed 98% pure (containing the equivalent of 98% of Sulphate of Copper.)

This material has been approved all over the world. Beware of the many adulterated mixtures upon the market.

SULPHATE OF COPPER,

Charlock brand, guaranteed 98% pure, immediately soluble.

This SULPHATE OF COPPER is quite unlike the ordinary powdered sulphates as by a special process it is rendered immediately soluble in cold water.

Potassium Sulphide.

Sulphur (pure flowers).

Soft Soap (guaranteed to contain at least 8% Potash, and to contain no resin, made from Linseed Oil).

Caustic Soda 98% and 70%.

And all other similar Chemicals of high purity for the special purposes required.

ASK FOR BOOKLET No. 46.

STRAWSONS (DEPT.)

WHOLESALE CHEMISTS,

71a, Queen Victoria Street, LONDON.

Horticultural Requisites.

“GISHURST COMPOUND”

For preventing and destroying **Red Spider, Green Fly, &c.** Harmless in use. Its soluble sulphur, &c., has for 40 years cured **blights and fungus** on plants. It is also useful for washing unhealthy dogs.

“GISHURSTINE”

For the protection of **Boots and Shoes** from damp, ensuring comfort and health to the wearers. Boots treated with Gishurstine take polish. It is also good for use on harness.

SOFT SOAP

Specially prepared as an **insecticide**, including

“SOFT SOAP and Quassia.” “SOFT SOAP and Paraffin.”

To be obtained from all dealers in Horticultural Requisites, or Wholesale from

PRICE'S PATENT CANDLE COMPANY LIMITED,
LONDON, LIVERPOOL and MANCHESTER.

EVERY DESCRIPTION OF

SCIENTIFIC APPARATUS.

Microscopic Slides (specially white),

Cover Glasses (specially thin),

Accessories, Pure Chemicals.

STANDLEY BELCHER & MASON, Ltd.,

LUDGATE HILL, BIRMINGHAM.

Telephone No. 3825.

Telegraphic Address: “Laboratory, Birmingham.”

CAMPBELL'S PATENT . . . SULPHUR VAPORISER.

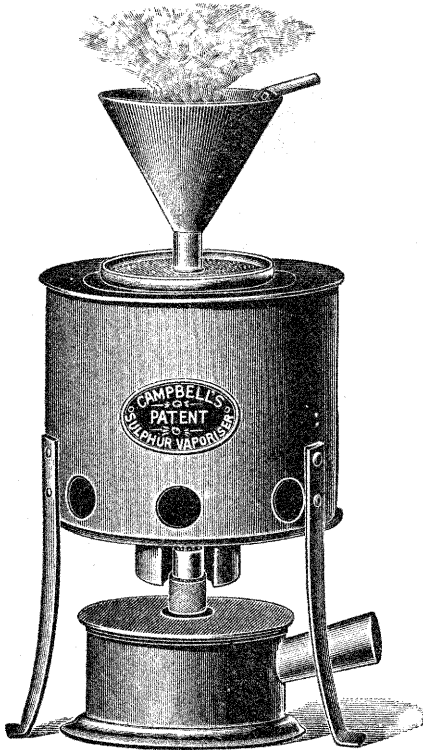

**ABSOLUTELY
BEST REMEDY**
FOR
Mildew and all

Diseases of .

Plants and .

Fruit Trees .

IN GREENHOUSES.



Campbell's CAUSTIC ALKALI WASH, for the winter washing of dormant fruit trees, kills all lurking Insects and Eggs, and leaves tree in a healthier and cleaner condition amply repaying cost and labour.

Campbell's NICO SOAP, a mixture of nicotine and soft soap, destroys Aphis and Thrip infesting Plants, Fruit Trees, Hops, &c., far more effectual and cheaper than Quassia, Petroleum and other old fashioned mixtures.

Campbell's BORDEAUX MIXTURE, instantly soluble in water, free from grit, and altogether both better and cheaper than the home made article.

For further particulars apply to—

Exors. ROBERT CAMPBELL,

Manufacturers of Nicotine, Weedkillers, Fumigators, Insecticides, and Fungicides, Manures and all Chemicals, for use in Horticulture and Agriculture.

Water Street, MANCHESTER.

To Fruit Growers, Horticulturists, &c.



THE **'MACKENZIE'** **SPRAY.**

An absolutely reliable portable Spray. Can be used with 1, 2 or 3 nozzles, and the tubing connected with the handle can be lengthened by screwing on the additional tube rods supplied.

A pump; C rubber tubing; D brass tube with wooden handle at one end and Spraying Nozzle at other end; E pump supports, pivoted for folding up. The iron vessel for spray fluid is shown in dotted lines.

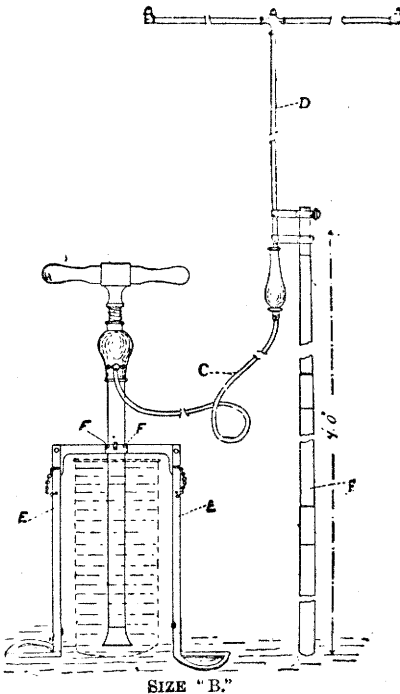

Price of Sprays—

SIZE A.—For ordinary work, with Cross Piece and Two Nozzles, additional rods and rubber tubing - **£2-2-0**

SIZE B.—With Cross Piece and Three Nozzles, Lengthening Rods and Rubber Tubing - - **£3-3-0**

Special made Iron Vessel for Spray fluid, **7/-**

To be obtained only from—

The Thresh Disinfector Co., Ltd.,

16, GT. GEORGE STREET,

WESTMINSTER, LONDON, S.W.

DESTROY CHARLOCK

(Yellow Weed
Kedlock, Wild
Mustard, Kilk,
etc., etc., etc.)

In growing Crops of Corn, Peas, Beans, Clover, Grass, etc.

16 to 20 bushels extra corn per acre.
Great improvement in quality of corn, owing to full benefit of manure and mould and moisture.
Absence of Charlock checks the flea beetle and the club root.
Improvement of land (Charlock almost poisons the soil).
Spraying is ABSOLUTELY CERTAIN. It kills the Charlock both in and between the drills.
A Sprayer does 12 to 30 acres daily (compare hoeing half-acre daily).
Hoeing kills Charlock only between drills, and with hand pulling is very expensive.
Ploughing up all the crop, or turning on the sheep, is a pitiful waste.

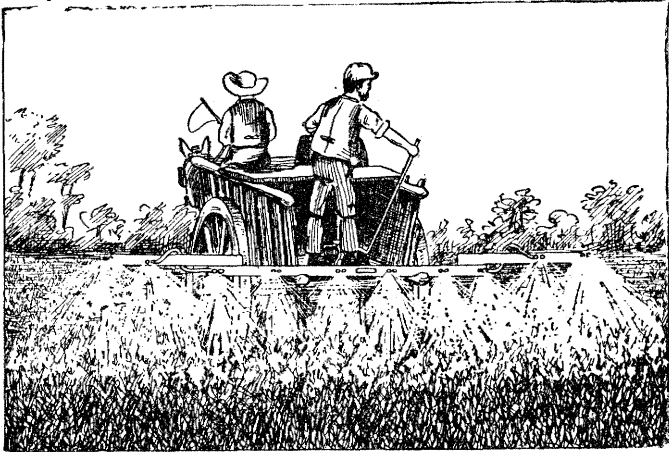

No. 1. To spray from 12 acres daily (8 nozzles) - £6-15-0
No. 2. " " 20 " (12 ") - £8-15-0

A colossal success awaited the Charlock Spraying Process (originally by Strawsons in 1838). Huge Sales in all parts of the world have been made. There is a heavy money profit in the process. Farmers should write for Booklets, Farmers' Testimonials, College Reports, etc., etc.

STRAWSONS' SPRAYERS.

Sulphate of Copper (Charlock Brand), specially prepared for Charlock Spraying, 98% pure. The only brand of the kind which is immediately soluble in cold water. Beware, especially of ordinary ground sulphates, which are quite unlike Charlock Brand. Ask for Booklet 5a (New Edition).

SPRAYERS FOR WINTER SPRAYING.

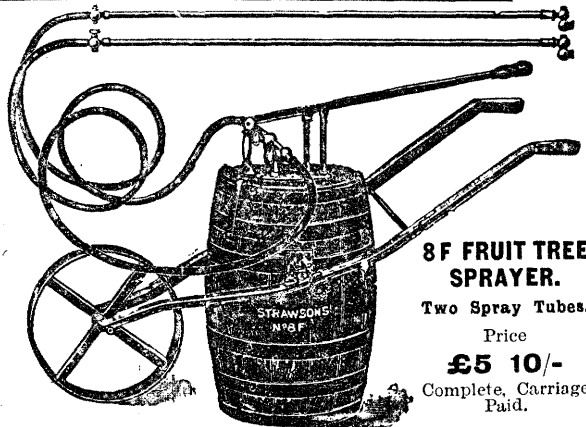

8F FRUIT TREE SPRAYER.

Two Spray Tubes.

Price

£5 10/-

Complete, Carriage Paid.

it pays up-to-date growers to Spray their Fruit Trees, for a sound crop commands a ready sale, and makes a good price.

USE STRAWSONS' REALLY PRACTICAL SPRAYERS.

The old way (infected Trees and unsound Fruit) does not pay.

Write for Catalogue of our various Machines.

Repairs Promptly Executed. All Duplicate Parts supplied from Stock.

MACKIES LIMITED, Caversham Road, READING.

HEARSON'S PATENT "CHAMPION" INCUBATORS.



Testimonial from the UNIVERSITY COLLEGE, READING.

College Poultry Farm, Theale, Berks,
February 1st, 1907.

Dear Sirs,—As a result of my previous experience and the experiments and observations in artificial incubation made during the last three years at the College Poultry Farm, Theale, I cannot speak too highly of Hearson's Champion Incubator. It has given in each year the highest average percentage of hatching, whilst from its simplicity in operation, its absolute reliability of temperature, and the excellence of its construction, it is undoubtedly the best incubator on the market.

Yours faithfully,
(Signed) EDWARD BROWNE,
Lecturer in Aviculture.

HEARSON'S FOSTER MOTHER

(The "Hydrothermic")

For Outdoor Rearing of Chickens in Winter or Summer.

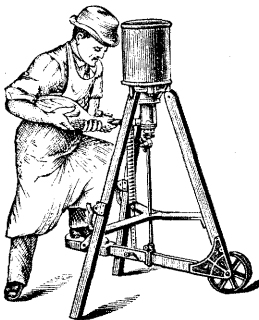
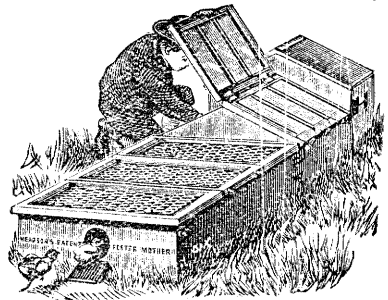

HEARSON'S PATENT CRAMMING . . . MACHINE

For the Forced Feeding of Fowls, Turkeys, etc.

Show Rooms: 235, Regent Street, London, W.

Sole Agents—

Write for Illustrated Catalogue,

SPRATT'S PATENT, LTD.,

24 & 25, Fenchurch Street, London, E.C.

BAYLISS,

JONES and BAYLISS, LIMITED.

— Manufacturers of —

IRON & WIRE FENCING, RAILING, GATES, &c.

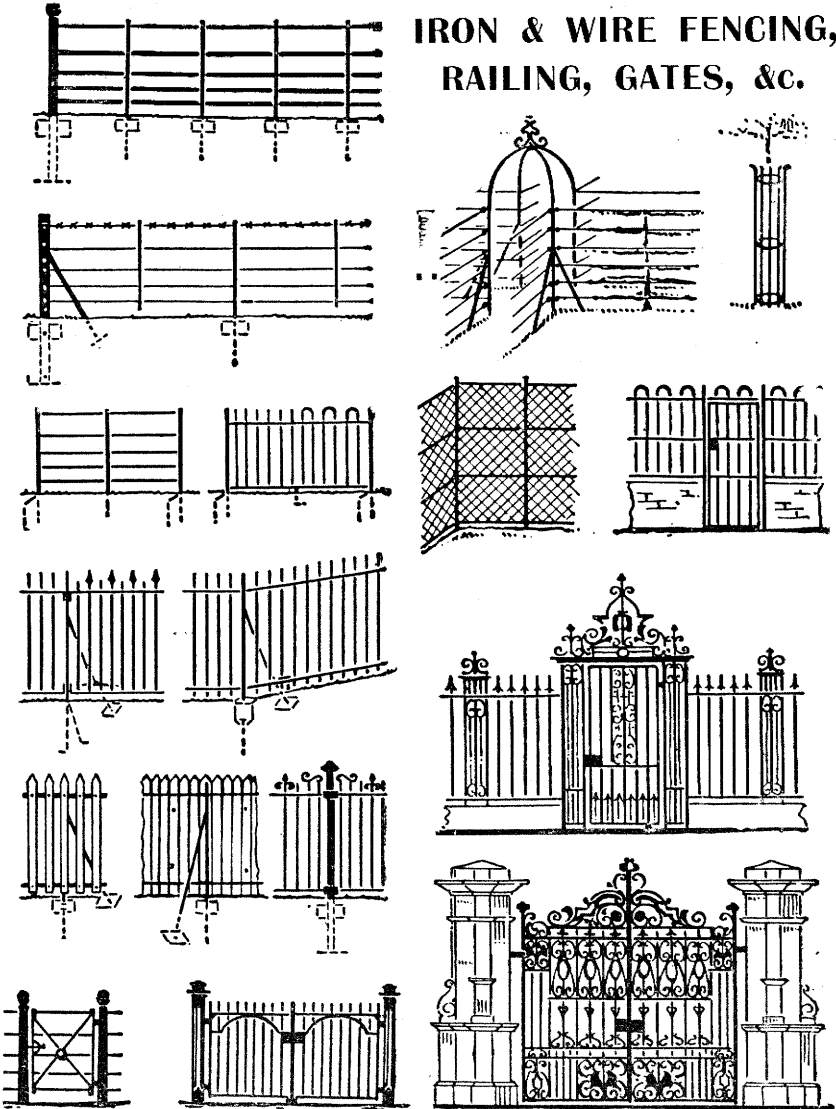

Illustrated Catalogue Free.

WOLVERHAMPTON,

And 139 & 141, CANNON STREET, LONDON, E.C.