

Desirable

June, 1925

RADIO IN THE HOME

Conducted by

HENRY M. NEELY

10¢



*The
Man in
the Silver Mask*

EVEREADY HOUR
EVERY TUESDAY AT 8 P. M.
Eastern Standard Time

For real radio enjoyment, tune in the "Eveready Group." Broadcast through stations—

WEAF	New York	WEAR	Cleveland
WJAR	Providence	WSAI	Cincinnati
WEEL	Boston	WWJ	Detroit
WFI	Philadelphia	WCCO	Minneapolis
WGR	Buffalo	WOC	St. Paul
WCAE	Pittsburgh		Davenport

Evereadys have long-lasting power

THE long-lasting power of Evereadys more than justifies their price. It is false economy to buy batteries that may be cheaper in first cost, but which are much shorter lived. Considering price and size, Evereadys are the most economical batteries there are, and in addition they are most satisfactory. Buy Eveready "B" Batteries. To light the filaments of all radio dry cell tubes, use the famous Eveready Columbia Ignitor.

Manufactured and guaranteed by
NATIONAL CARBON COMPANY, INC.
 New York San Francisco
 Canadian National Carbon Co., Limited, Toronto, Ontario

EVEREADY Radio Batteries

—they last longer



Eveready
 Columbia
 Ignitor
 "A" Battery
 The proven
 dry cell for
 all radio
 dry cell tubes
 1 1/2 volts

No. 766
 22 1/2-volt
 Large
 Horizontal
 Price
 \$2.00

No. 772
 45-volt
 Large
 Vertical
 Price
 \$3.75

No. 764
 22 1/2-volt
 Medium
 Vertical
 "B"
 Battery
 Price
 \$1.75

EDITORIALLY SPEAKING

By HENRY M. NEELY

WITH the present issue, this magazine begins its fourth year of publication. All of the leading radio magazines were established just about the time we were and I notice that it is an annual custom with them on their anniversaries to devote considerable space to a detailed account of the splendid work which they have accomplished in the last year for the benefit of their readers and to congratulate their readers on the possibility of securing such magazines.

In the cases of the other magazines, this may perhaps be justified. In the case of this magazine I cannot quite feel that way about it. I feel that a birthday anniversary with us should be the occasion of publicly congratulating ourselves not upon our achievements but upon the splendid loyalty of our veteran readers and the very generous encouragement given to us in letters from new readers.

I can only say, as a birthday greeting, that we hope some day to make this magazine at least one-half as good as this loyalty and encouragement deserve. You who are buying our magazine month after month are the ones who are making it possible for us to do anything at all, and no one is more painfully conscious than I am of the fact that we have not yet been able to give you quite what you are entitled to. I hope you will believe me, however, when I say that we are working just as hard as we possibly can toward that end and that we intend some day to be able to make the magazine really representative of your viewpoint of radio.

So much, then, for the usual birthday greetings. We wish you many happy returns of the day and we want you to tell us how to make each return a happier one for you.

It so happens that this birthday anniversary falls in a month which marks the ending of what is known as the "season" in radio. It therefore gives an excellent opportunity to look backward over the last twelve months to take stock of what has happened and to attempt to look forward over the coming twelve months to lay our plans for what is likely to occur.

Fortunately this seasonal aspect is gradually disappearing. I personally doubt whether radio will ever be as popular in the summer time as it is in the winter time, no matter what improvements are made in it. This is not to be taken as meaning that we will not some day secure just as good reception in August as we do in December; I think we will in time accomplish this object. But human nature is human nature all the world around, and the man with red blood in his veins does not stay in the house in the summertime as he does in winter. He likes to get out in the open and spend as much time there as he possibly can. He has a garden or an automobile or a bag full of golf clubs or even a butterfly net and a bottle of cyanide or whatever it is they use. There is something that lures every one out into the fields or the

compelled to remain in the city in the hot weather, radio is getting to be increasingly valuable.

Heretofore we had two very serious drawbacks to contend with so far as summertime reception was concerned. These were the fact that radio signals do not travel as far in summer as they do in winter time and, in addition and probably more important, the unfortunate atmospheric condition known as static, which has usually made summertime reception anything but a pleasure.

This summer there are over a dozen stations operating on higher power up to something like 1500 watts. This does two very important things: It makes their signals travel farther than they did before so that they can be heard by more people, and, for those who are fairly close to them, it increases the signal strength to such an extent that the total volume in the loudspeaker can be toned down sufficiently to eliminate ordinary static, but still leave enough signal strength to give very good speech and music for an evening's entertainment.

Summertime reception will be better this year than it ever was before; it will probably be even more improved by next summer.

I look for a radio audience nearly twice last season's size before next Christmas. All over the country, in every large city, the department stores have been offering for sale the most wonderful bargains in radio equipment that I have ever known. Standard four and five tube sets of the best makes, with

good loud-speakers, tubes, batteries and all equipment, have been offered to the public for prices of less than one hundred dollars and on time-payment terms.

This has totally disorganized the radio industry because it has dumped on the market several hundred thousand radio receivers at prices which cannot possibly be met at present by the average manufacturer on his new line of goods. Consequently, he has been virtually driven out of the market for the present and is forced to sit back and wait until this tremendous supply of equipment is once more ready for his new models at prices on which he can make a legitimate

(Continued on Page 23)

Volume IV	CONTENTS FOR JUNE, 1925	No. 1
Cover Design— <i>Earl K. Bergey</i>		PAGE
Editorially Speaking— <i>Henry M. Neely</i>		3
The Sound of the Silvertown Chimes— <i>Golda M. Goldman</i>		5
Those Short Waves— <i>E. T. Flewelling</i>		7
All Records Smashed by WOA— <i>Eugene Konecky</i>		8
Counterflex Circuits for Experimenters— <i>Kenneth Harkness</i>		11
Let's Cut Out Those Whistles— <i>R. S. McBride</i>		13
Now Women Demand Their Share of Programs— <i>Elizabeth Hallam Bohn</i>		15
How to Make the New Quadraformer Receiver— <i>E. J. Gearhart</i>		18

Published Monthly by the Henry M. Neely Publishing Company, 608 Chestnut St., Philadelphia, Pa.

Bell Telephone—Lombard 8431 Experimental Station (3XP), Delanco, N. J.

HENRY M. NEELY.....President and Editor
 G. W. KRAFT.....Secretary and Treasurer
 W. L. DUDLEY.....General Manager
 NORMAN NEELY.....Art Director

B. M. MORRIS.....Advertising Manager
 MERRILL NEELY }
 G. P. ALLEN.....Laboratory Assistants

Radio in the Home is sold at 10c per copy at all newsstands, radio shops and bookstores. Subscription rates in the United States, \$1.00; Canada, \$1.25; Foreign, \$2.00 per year.

Printed on the rotogravure presses of the Public Ledger, Philadelphia, Pa.
 Copyright, 1925, by the Henry M. Neely Publishing Company
 Entered as second-class matter May 26th, 1922, at the Postoffice, Philadelphia, Pennsylvania, under the act of March 3, 1879.

woods or the open spaces where we can fill our lungs with pure air and, for the time being, forget the stuffy office and the grinding monotony of business and the deadening routine of time clocks and whirling machinery.

Daylight-saving time also gives us an extra hour of freedom from darkness, and every moment of this precious boon is ours to add to the time we can spend in the open.

For those who do not wish to do this—and there probably are a great many—radio is holding out more and more value as a summertime recreation. For the shut-in or the old folks or the man or woman

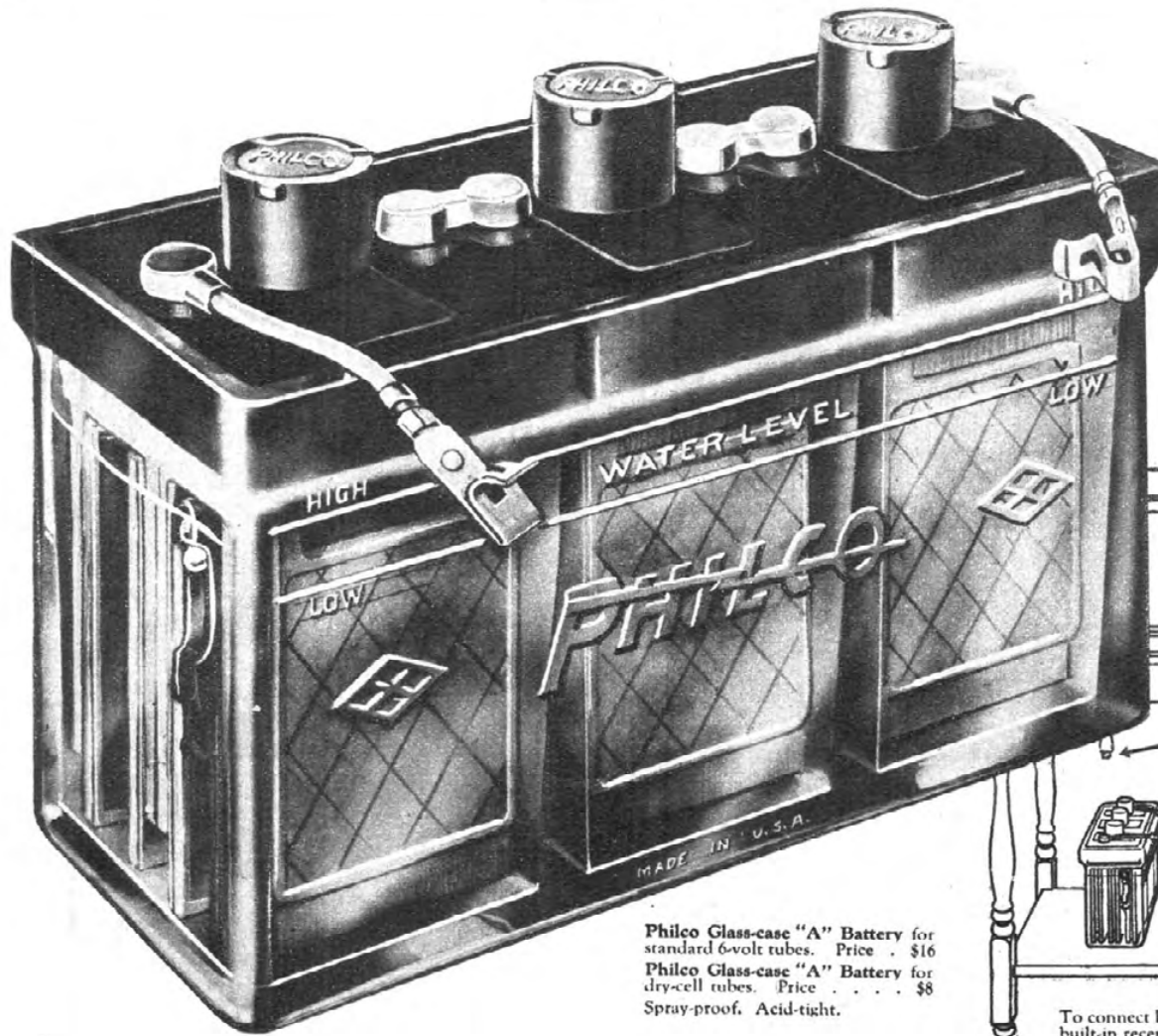

Philco Glass-case "A" Battery for standard 6-volt tubes. Price . . \$16
 Philco Glass-case "A" Battery for dry-cell tubes. Price \$8
 Spray-proof. Acid-tight.

Philco Double Charger for all "B" batteries and UD86 "A" Batteries. Noiseless. . . . Price \$15
 Philco Single Charger for all "B" batteries and UD44 "A" Batteries. Noiseless. . . . Price \$9.75
 Charger Prices include plugs and receptacles.

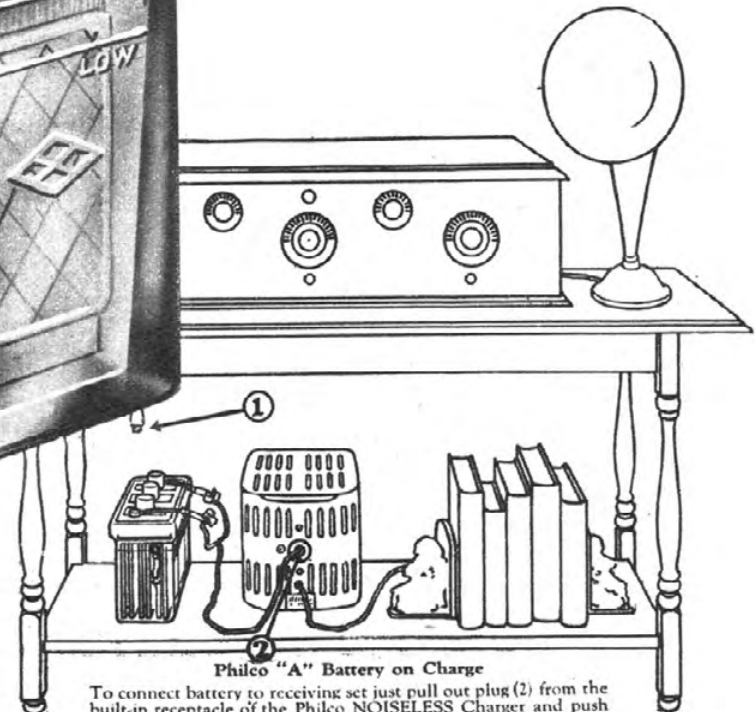

Philco "A" Battery on Charge
 To connect battery to receiving set just pull out plug (2) from the built-in receptacle of the Philco NOISELESS Charger and push into receptacle (1). Simple as A B C.



Philco "B" Battery

Storage "B" Batteries are just as essential for clear and distant reception as storage "A" Batteries. Philco "B" Batteries stay clean and dry. To charge without disconnecting a single wire, use a Philco Charger and "B" Charging Panel (\$2.75).
 "B" Battery in de luxe mahogany-finish case with cover (48 volts) \$20
 "B" Battery in handsome mahoganized case without cover (48 volts) \$16.50



Philco Mahoganized-Case "A" Batteries

Two types—RAR and RW—for 6-volt tubes. Both in beautiful Adam-brown mahogany-finish cases harmonizing with your radio cabinet. Price \$14.50 up
 Philco Charge Tester—permanently mounted in filler cap, avoids fussing with hydrometer. \$1 extra.

Recharge in your living room without changing a wire

Recharging a Philco Radio Battery with a Philco NOISELESS Charger means merely pulling a plug from your radio socket and pushing it into the charger socket. No changing wires. No moving the battery.

Philco Radio Batteries—both "A" and "B"—have other big advantages that make storage battery operation easy, convenient, and economical.

They are assembled in attractive acid-tight, spill-proof glass cases—or in wood cases finished in beautiful Adam-brown mahogany. They have exclusive built-in

Charge Indicators that tell you at a glance how far the battery is charged or discharged.

No matter how expensive your radio set—whether it has one tube or many tubes—you must have the steady voltage and strong non-rippling current of a good STORAGE BATTERY for the best results.

Philco Radio Batteries deliver strong non-rippling current *without hum, roar or buzz*. You can buy them from your nearest Philco Service Station, Radio or Music Dealer.

Philadelphia Storage Battery Company, Philadelphia

MOTOR CAR OWNERS—avoid the danger and humiliations of battery failure by installing high-powered, long-life Philco Diamond-Grid Batteries. With Philco Retainers, they are **GUARANTEED FOR TWO YEARS**. Philco-made automobile batteries range in exchange price from \$14.50 up.

PHILCO DIAMOND GRID BATTERIES

RADIO IN THE HOME

Grimes-Flewelling-Harkness

Associate Editors, Writing for No Other Magazine

By
**GOLDA M.
GOLDMAN**

IT IS almost unnecessary to introduce the radio audience to Mr. Phillips Carlin, the good-looking announcer of WEAF, whose voice so many people confuse with that of Graham McNamee.

Mr. Carlin has announced so many of the big features that it is hard to think of the Astor Coffee Orchestra, or the Silvertown Chimes, or the Happiness Boys without associating them with this cheery personality. He is a great lover of music and an excellent linguist, all of which has equipped him especially well for the handling of fine programs. As a humorist and as a sympathetic interpreter of all the fine music which travels through the microphone from 195 Broadway, he has made himself welcome night after night, but with the Silvertown Orchestra he made a new debut. He fairly blossomed forth. He took us by storm;

he proved himself a past master of the intriguing art of *playing the castinets!*

Perhaps I have begun this at the wrong end. Probably I should have gone back and allowed the soft ringing of the chimes to open this program for you as they have done beautifully every week since the first program last fall. Then you have heard Mr. Carlin's voice say, "The Silvertown

apolis-St. Paul, and WSAI, Cincinnati. If you have heard them before, you know how irresistible they are, and if there are any newcomers among you radio listeners, be pleased to forget everything but the music and the dance."

And then the music begins.

If Joseph Knecht, leader of the Waldorf-Astoria Dinner Orchestra, who has done



"The Man in the Silver Mask," who is heard with Silvertown Cord Orchestra on Thursday evenings from 10 to 11 through stations WEAF, New York; WJAR, Providence; WCAE, Pittsburgh; WEEL, Boston; WFI, Philadelphia; WGR, Buffalo; WWJ, Detroit; WCCO, Saint Paul-Minneapolis; WCTS, Worcester; WOC, Davenport, and WSAI, Cincinnati, pictured with crown sent to him by enthusiastic radio fan

Photograph by FOTO TOPICS, Inc.

Chimes have rung out their greeting. Each week they have announced an hour of music, a program of dance music so delightful that it drives all thoughts of care away. The B. F. Goodrich Rubber Company, manufacturers of Goodrich Silvertown Tires, engages the facilities of WEAF, New York; WJAR, Providence; WFI, Philadelphia; WCAE, Pittsburgh; WGR, Buffalo; WEEL, Boston; WWJ, Detroit; WOC, Davenport; WCCO, Minne-

The Sound of the Silvertown Chimes



so much to popularize radio dinner concerts, does not know how to make you "forget everything but the music and the dance," then no one in America does. Not that Mr. Knecht started his career with the intention of waving a baton; on the contrary he was to be a civil engineer. Born in Bukovina, in South Austria, a land famous for its great musicians, he naturally grew up in the midst of a people who took for granted the important place which music should play in every one's life. He followed only the natural bent of all his countrymen, when at 5 years of age he began to play the violin. When he finished high school, he persuaded his parents

Silvertown Cord Orchestra with their leader, Joseph Knecht, and "Man in the Silver Mask," assisting Phillips Carlin, popular WEAf announcer, in the art of castinet playing

Photograph by FOTO TOPICS, Inc.



Joseph Knecht directing the Silvertown Cord Orchestra with the "Man in the Silver Mask" singing

Photograph by FOTO TOPICS, Inc.



to allow him to go into the Vienna Institute of Technology. Since they were too poor to finance him, he bravely endeavored to pay his own way by playing outside his school hours.

This was a tremendous undertaking in a city filled with boys of talent in exactly his own position; but his genius was sufficiently marked to find him a place in the Vienna-Hofburg Theatre. Then advice began to be offered on all sides to the effect that his place was in the Vienna Conservatory. He entered there and soon found his progress so rapid that, just before he was ready to graduate from the Institute of Technology, he left to devote all his time to music.

We find him passing in rapid succession from the Royal Opera House in Vienna to the Boston Symphony Orchestra, and thence to the Metropolitan Opera in New York, where he became concert master and finally associate conductor. During the summer of 1912, when the opera was closed, the late George C. Boldt, the president of Waldorf-Astoria, Inc., asked him to organize the Waldorf-Astoria Symphony Orchestra. The success of this feature was so immediate that he never resumed his duties at the Metropolitan; instead he gave concerts in the Grand Ball Room of the Waldorf-Astoria.

The feature became so popular that the guests of other large hotels visited the Waldorf constantly for the pleasure which they derived from this new symphony orchestra. At first excellent soloists also appeared, and very shortly every first-class hotel in the country was attempting something on the same order.

Knecht's influence and musical position were so potent that he

(Continued on Page 30)

Those Short Waves



About Our Friend Flewelling

MR. FLEWELLING'S recent articles giving such very clear and simple explanations of the various losses in receiving sets have created probably more favorable correspondence than any series which this magazine has yet run. The best part about our friend Flewelling is that while he is a real expert, he doesn't write like one. He writes like an ordinary fan who has not forgotten how to talk ordinary language. Consequently, other ordinary fans are able to understand him where they would be totally lost in the mazes of the technical terms and style of the average radio engineer.

It will probably be of interest to our readers to know that a man who can write as simply and as clearly as he, can, at the same time, command the respect of leaders of the science.

Almost three years ago, Flewelling's articles in various magazines did much to start the agitation for short leads, low losses and so forth, and they may almost be looked upon as the beginnings of the modern low-loss movement.

Flewelling's talk about building and not "tying" sets together with wire was recognized at the First Radio World's Fair at New York, when he was awarded the first prize silver cup against the field for the "most constructive advancement in receiver set design."

Again at the Chicago show, Flewelling's successful opening of the show by his short-wave radio transmitter resulted in his again receiving a silver cup, this time for "ultra valuable contributions to the radio art."

Flewelling is a member of Technical Advisory Boards of the Radio Manufacturers' Association of Chicago, the Associated Manufacturers of Electrical Supplies, New York; the Broadcast Listeners' Association of Chicago; the Milwaukee Radio Amateurs' Club, and the Radio Section of the Electric Club of Chicago, of which he is vice chairman. These are aside from his titles of A. M. I. R. E. and Associate Editor of "Radio in the Home." Incidentally, it may interest our new readers to know that Mr. Flewelling does not write for any other publication and that they can get the full benefit of his knowledge and advice through this magazine without the necessity of hunting through others.

H. M. N.

E. T. Flewelling and his short-wave transmitter, Station 9XBG

By E. T. FLEWELLING

Associate Editor of "Radio in the Home"

PERHAPS the most popular indoor sport today in the radio world is the discussion of "short waves." Everybody seems to be of the opinion that the use of short waves will surely and undoubtedly "revolutionize" the art and cause all present-day receivers to be thrown into the discard.

In my studies of losses in receivers I have used short waves because the requirements are more rigid than when the longer waves in the broadcasting bands are used. This work has brought me in rather close touch with the short-wave field for some time, and I feel that there are a few points on the subject that I would like to pass on to my friends.

There are many advantages to be gained by the use of short waves, but like most things in this old world of ours there are also disadvantages. In this age of rapid advancement there seems to be an ability on the part of the human race to turn disadvantages into assets or at least to overcome them, so that perhaps a good way to handle our subject will be to consider some of the objections to short waves first, confident in the thought that they will in time probably turn out to be blessings in disguise.

It is popular belief that short waves cover much greater distances with less power expenditure and that we are therefore assured of more reliable reception. It

is true that short waves do reach out to greater distances than the longer waves, but it happens that they do so quite often very erratically. It is almost as though the longer waves in comparison were the "slower" but surer type.

To illustrate what I mean—suppose a short-wave transmitter is broadcasting from Boston on the East Coast. We have noticed many times that while receiving stations in California or on the West Coast were receiving the message clearly and strongly, yet stations in the central part of the country like Chicago or St. Louis, or perhaps even closer to the transmitter as Buffalo or Albany, N. Y., were not able to hear the message at all.

Now this skipping over a section in favor of a more distant point seems to be quite dependent on the length of the wave used, and while nothing definite has yet been proved, still we know that such a condition does exist under certain circumstances and for general broadcasting it might be quite troublesome.

It would never do for instance to broadcast from Boston, have the signal skip our own country altogether and land in China, unless, of course, we wished to broadcast for the benefit of the Chinese. However, this skipping does not seem to be prevalent except on waves of particular shortness, such, for instance, as in the neighborhood

of twenty-five meters, and, therefore, is not a source of trouble at the present time. At some future date no doubt we shall find that we can take some advantage of this characteristic.

Perhaps the greatest difficulty with short-wave transmission of music, etc., lies in what is called *audio-frequency fading*. It appears that in common with the longer waves, short waves also fade in and out during the transmission, but that at times the fading happens so rapidly as to produce a sound of its own. This results in blurred or mushy speech or music.

Audio-frequency fading seems, however, to have something in common with the ordinary fading in that it more often than not is quite local to the receiver in nature, that is *fading out* or growing weaker at one receiving station and at the same instant be *fading in* or growing stronger at another station two or three miles away. So frequently, in fact, does this condition obtain that very reliable reception may be had by connecting two or more receivers, located several miles apart, together to one output, thus endeavoring to have one receiver balance against the other. But this, of course, does not help the individual much for he would find it difficult probably to have several antennae located so far apart.

However, it is possible by this method for a broadcasting station to cover greater distances by using the

(Continued on Page 37)

All Records Smashed *by* WOAW

By EUGENE KONECKY

APRIL 2d, 1923, 9:00 P. M. was the occasion for the first cry of a new-born radio station issuing into the ether and thence into the ears of hundreds of thousands of confirmed radio bugs.

At that time the advent of the new station was marked by a remarkable number of radio applause letters and the executives of the Woodmen of the World Life Insurance Association, which owns and operates Radiophone WOAW, especially W. A. Fraser, president, who was chiefly instrumental in the creation of WOAW, felt that their expectations were more than realized and that they had made no misjudgment in adopting radio transmission as the means for maintaining their fraternal beneficiary insurance organization abreast of the times. However, little did they dream that two years later this same radio infant would establish unprecedented records in reported reception of radio programs.

For weeks the managers of WOAW, including Orson Stiles, director of the station, the announcers, operators and hostesses, had planned to the last detail the complete direction of the birthday anniversary programs. Every possibility was plumbed and catalogued, as well as assigned to some particular, responsible person. Systems were devised for the recep-



A view of the avalanche of telegrams received by WOAW on the anniversary programs. Pretty Virginia Swanson, a Woodmen of the World employe, is almost submerged beneath the 21,972 telegraphic responses

tion of telegraphic communications, phone calls (local and long distance) and letters. Arrangements were made for the distribution of prizes, of which there were thousands.

Yet, in spite of all this careful preparation and provision, the actual results swamped and almost paralyzed the entire staff of operators, announcers, hostesses and clerks. The Western Union Telegraph Company experienced the same problem and exactly the same results. With double shifts and the supervision of experts and with complete methods to receive the expected rush of telegrams all fully set and primed, still they could not meet the onrush of communications from radio fans and for ten hours valiantly struggled to maintain pace with the increasing avalanche of telegraphic responses to WOAW's prize anniversary program.

Before offering any statistics, let us first see what it was that caused this remarkable event. WOAW in the two years of its existence has been very popular, not only in the vast Middle Western region of the United States, but also in the North, East, South and West, where reception of the 1000-watt station has always been clear and consistent. In other words, WOAW had, as the basis of its success, an appreciative audience of great size, thoroughly

Below: Art Landry and his famous Victor Recording Jazz Orchestra, which was featured during the anniversary programs, playing at half-hour intervals from midnight until 4 in the morning

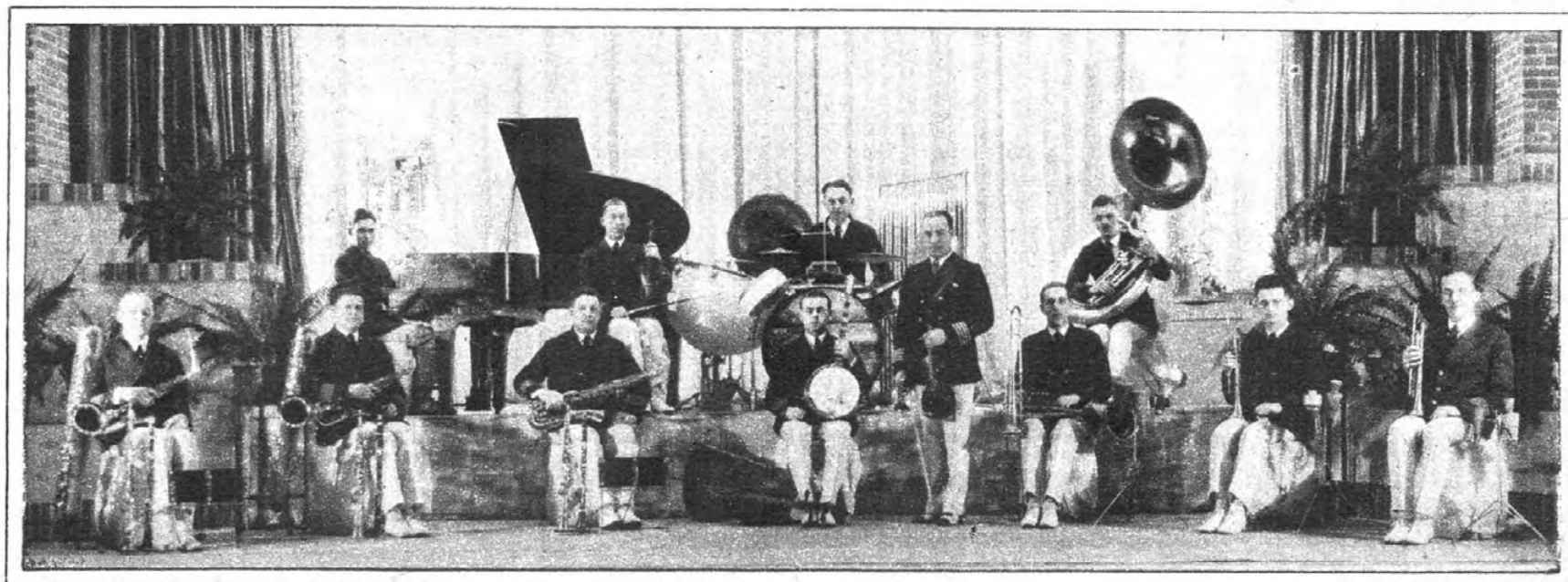

familiar with the history of the station and its talent. These listeners knew that an anniversary affair from WOAW could not be other than unusual, and they were prepared to listen from the start to the finish to the de luxe offerings.

In addition to this, repeated announcements had been made of special arrangements with featured artists for the anniversary programs. These artists included Randall's Royal Fontenelle Hotel Orchestra, and Art Landry and his famous Victor Recording Orchestra of the Brandeis Store Restaurants. These two orchestras have a national reputation.

In addition to this, the Tangier Temple Shrine Band was scheduled to radiocast; also well-known local orchestras of the jazz type—the Shanghai and the Adams (colored) jazz orchestras. Well-known soloists, including Harry Brader, violinist; Frank E. Strawn, pianist, and a host of vocalists, were also on the program, and finally the Elks' Quartet of Council Bluffs, Iowa; the Kiwanis Quartet, the Reese String Quartet and the Skeen trio, WOAW favorites, had been announced to play. These did not compose the entire program, but were special features. Prominent local citizens and orators were also on the program, including:

James C. Dahlman, Mayor of Omaha.

Jack Harding, Mayor of Council Bluffs.

W. D. Hosford, president Ak-Sar-Ben.

Rev. Frank Anderson, secretary Omaha Ministerial Union.

Ballard Dunn, editor Omaha Bee.

Neal Jones, managing editor Omaha Daily News.

W. H. Graham, radio editor Omaha World-Herald.

Clarke Powell, commissioner Omaha Chamber of Commerce.

Mrs. J. W. Gill, president-elect Omaha Woman's Club.

Edwin G. Stevens, secretary Omaha Musicians' Association.

J. H. Beveridge, superintendent Omaha Public Schools.



Eugene Konecky and, to left, L. P. (Lester Palmer), the two announcers who "put over" the 19 hours of radiocasting, reading 19,000 prize awards at the rate of 166 2/3 words per minute for five consecutive hours, relieving each other at intervals of half hours

Col. T. E. Patterson, sovereign auditor of W. O. W.

M. V. Robins, U. S. Government meteorologist.

Major J. M. Pruyn, U. S. Army headquarters.

Therefore, we may generalize and say that the second factor accounting for the tremendous success of the anniversary program was the program itself, including the artists and performers.

But these factors alone do not entirely account for the epoch-making response which followed the programs. Another important factor was the list of prizes offered to listeners who responded either by telegram, long distance telephone calls, post cards or letters. These prizes were offered not in the spirit of commercial advertising, but were offered as a token of recognition by the directors of the station to the radio listeners for their loyal support in the two years of its radiocasting.

These prizes were contributed by 106 donors, representing some of the most reputable local, as well as national, business concerns. As a matter of fact, the majority of these prizes were unsolicited, and the original intention of the directors of the station was to offer the listeners a modest favor of some kind for their kindness in reporting reception; but, upon the initial announcement of the intention of the station to offer these small favors, the station was swamped with the proffered contributions of thousands of business organizations.

However, it was felt that it was not only impossible but also inadvisable to



Gene Rouse, announcer of Station WOAW, Omaha, Nebraska



This force of telephone operators in the Western Union office, receiving telegraph messages to WOAW on the afternoon of the anniversary, is but a portion of the full force of 197 persons employed in traffic and delivery departments. This was the largest amount of dispatches ever handled in the Omaha office in the history of the Western Union Telegraph Co.

handle all of these contributions, and so the list of prizes was reduced to a select class of articles and a total amounting to 23,451 prizes. In addition to these prizes, a special contribution was made by the Kellogg Company, of Battle Creek, Michigan, to provide every communicant, either by telegram, long-distance telephone, postcard or letter, who did not win one of the capital or major prizes, with a combination package of its cereal products. The offer was generous without a doubt, but it is certain that even Kellogg Company did not really estimate the tremendous whirlwind of responses which was to follow and cost them thousands of dollars. The prizes were valued from \$1 up to \$350, and were incredibly varied, as may be seen from the following brief list:

First of all, there were the capital prizes consisting of ten radio receiving sets; prizes of radio accessories including loud speakers and storage and dry batteries; cash prize of \$25; an assortment of personal wearing apparel for men and women, including shoes, slippers, hosiery, shirts, boys' blouses, neckties, silk and house dresses; foodstuffs and table supplies, including bread, cake, coffee, flour, breakfast foods, cookies, wafers, crackers and biscuits, bacon, dried beef, cheese, canned corn, butter, condensed milk, macaroni and spaghetti, eggs, mayonnaise dressing, pancake flour, starch, pickles, pineapples and milk; confections, including candies and ice cream; household furnishings, including varnish, furniture polish, Egyptian clay, laundry stove, brushes, rug, wallpaper, furnace attachment; a variety of beauty preparations and toilet articles; cigars, theatre tickets, roses, palms, subscriptions to periodicals; stationery and picnic sets; live chicks, jewelry, portraits, radio albums, toy cabs and taxi tickets, season basketball tickets, poultry tonic, tire and tube, motor oil, traveling set, camping outfit, panel switches and Ford accelerators.

One extremely important factor in regard to the prizes offered to listeners was the outstanding affirmation that there were no rules governing the award of prizes; that anybody who communicated would receive a prize of some sort through a simple general drawing of all the responses without condition as to time or particulars of reception, etc.

At 10.30 A. M., Central standard time, the first program commenced. For nine-



A view of the first batch of mail in the executive office of the Kellogg Company's plant at Battle Creek, Michigan, from which 159,496 packages of Kellogg's cereals were mailed as prizes to listeners

teen hours thereafter the studio was the scene of a constant stream of telegraphic messages. At 5 A. M., the following day both announcers, E. K. and L. P., signed off. It was only then that the results could be viewed in perspective, and some of the outstanding facts which were discovered are:

First, that the event had won such general recognition, that the Fox Film Corporation of New York City sent a special representative and cameraman to film scenes of the anniversary program, including "shots" of the performers, the telegraph responses, the prize drawing and the operating staff in action. It might be mentioned here incidentally that for the first time in radiocasting in the Middle West the sound of the clicking of the camera made during the actual filming of pictures was transmitted through the ether, into the ears of listeners.

Second, 185,447 responses were received from listeners. These responses were divided as follows: 2500 long-distance phone calls and 2500 local telephone calls, 2644 Postal telegrams and 19,328 Western Union telegrams, 158,475 postcards and letters. Never before in the history of radio reception had a like number of responses been received by any radio station for such an occasion and in such a brief period of time.

Third, that the Woodmen of the World Life Insurance Association was compelled to employ for a full week more than 160 clerks to receive, open the mail, read the letters, assist in the drawing of prizes and to distribute the winning responses to the various donors, who, in turn, distribute the actual prizes.

In order to handle the tremendous number of telegrams, the Western Union had a total force of 197 clerks, working in double shifts from 8 A. M., April 2, until 8 A. M., April 3, twenty-four consecutive hours of continuous

(Continued on Page 29)

Counterflex Circuits for Experimenters

Part 1

By **KENNETH HARKNESS**

Associate Editor of "Radio in the Home"

graphs and step-by-step wiring diagrams. I shall then be glad to publish constructional details of the circuits which appeal to the greatest number of readers. In the meantime, however, I shall merely show the hook-ups, explain the underlying principles of their operation and give the reader sufficient practical data to enable him to experiment with the circuits himself.

It might be well first to explain, briefly, the principles of the Counterflex system of controlling self-oscillation, as this system is used in all the circuits to be described.

Generally speaking, the Counterflex system controls self-oscillation by neutralizing the effects of tube capacity. In a well - designed

WHEN I started to write about the Counterflex circuit, eight months ago, I explained that the Counterflex method of controlling self-oscillation could be applied to a great many circuits. Two of these, the two-tube and three-tube circuits, have been very fully covered in preceding issues of *Radio in the Home*. This month I begin a series of articles outlining a number of other circuits incorporating the Counterflex system of controlling self-oscillation.

This series is written in response to the many requests I have received for information of this nature. For instance, a great many readers have asked how they can add a stage of radio - frequency amplification to the two-tube and three-tube Counterflex circuits. In a later article of this series I shall explain how this can be done; in fact, I shall show several different ways of doing it.

Some of the circuits we shall discuss are merely modifications of the two and three tube Counterflex circuits already published. Others are circuits with which I have experimented and which are different from those hitherto described. Still others might be called "theoretical" circuits, in so far as I have not yet actually tested their operation experimentally. In analyzing these circuits I shall attempt to outline the effects and results which the experimenter may expect from these hook-ups.

As the title of the series indicates, these articles are addressed to radio experimenters.

I am going to assume that the reader thoroughly understands "schematic" wiring diagrams, as they are called, and is familiar with the general principles and operation of radio receiving systems. I do not intend, at present, to give complete constructional details or any photographs of receivers using these circuits. Later I shall probably explain, in detail, how to build receivers using some of the circuits which we cover in this series; in fact, I shall appreciate it if readers will write and tell me on which circuits they would like complete constructional data, with photo-

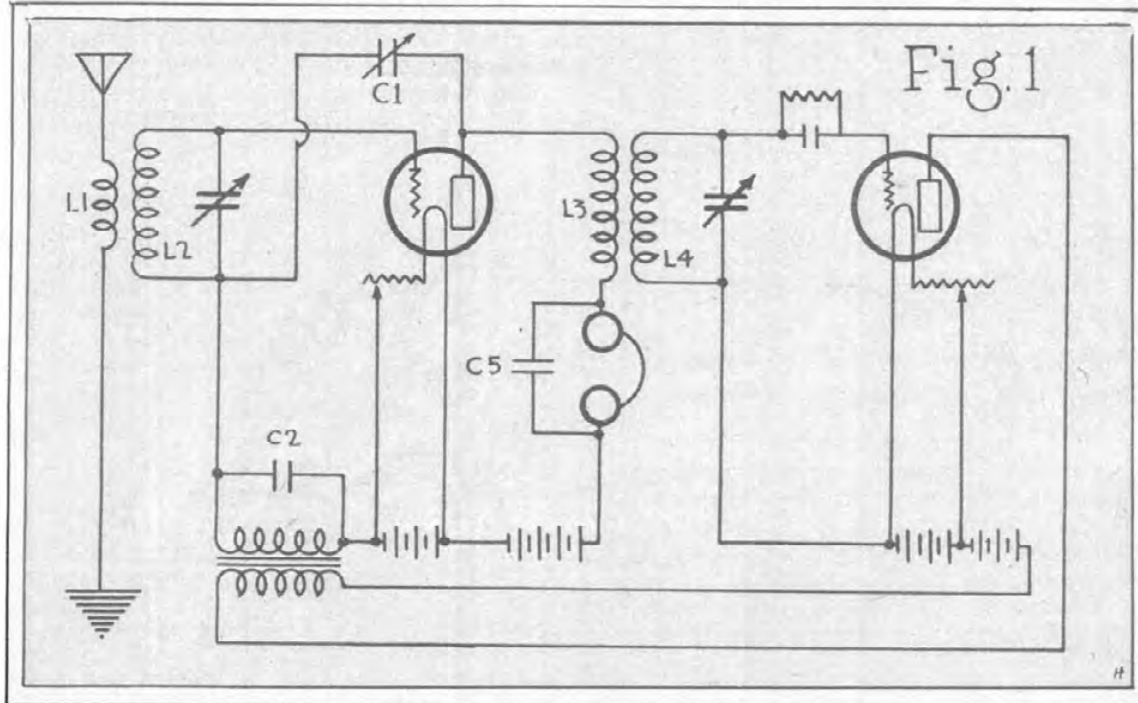

To Our New Readers
The Harkness Counterflex is one of the most successful circuits of this past season. It is good for both novice and experimenter. We can still supply the issues which Mr. Harkness mentions. See the back page of this number.

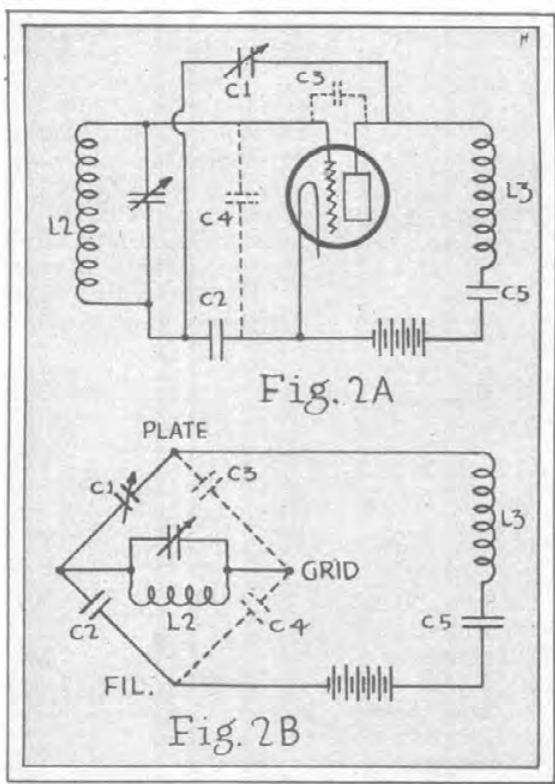

radio-frequency amplifying receiver the unavoidable capacity between the elements of the tubes is mainly responsible for the production of continuous oscillations. The internal capacity of a radio-frequency amplifying tube causes energy to be fed back from the plate to the grid circuit, resulting in regenerative amplification, or, if the feed-back is strong enough, in continuous self-oscillation.

While the regeneration is often desirable, the continuous oscillations must be checked. In Counterflex circuits this is accomplished by inserting an additional capacity coupling between the plate and grid circuits and connecting this capacity to produce a counteracting feed-back, a feed-back which is directly out of phase with the reacting feed-back set up by the tube capacity and which partially or completely neutralizes the effect of the latter.

As I explained in a previous article, the principle of this system of controlling self-oscillation was defined, in a general way, about ten years ago by French engineers, and practical methods of applying the principle were disclosed at that time. Since then, other methods have been developed, including the neutrodyne method, the Jones' method (first defined by Lester W. Jones, and used by him in the Melco receiver and the Grebe Synchrophase, also used in the Roberts' circuit), the Rice method and several others. All these

All the material in this article is fully protected by the copyright laws. Permission to republish, either in whole or in part, will be cheerfully given, providing the republication is fully credited to "RADIO IN THE HOME, Philadelphia." Otherwise this circuit and these instructions must not be used by other publications nor in any other unauthorized manner.
 H. M. N.

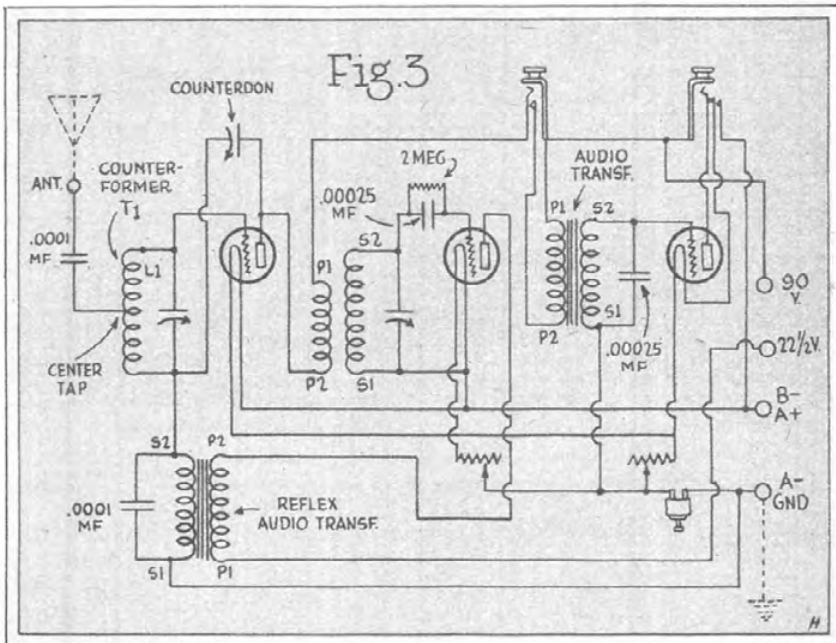

methods, including the Counterflex, operate on the same general principle and differ from each other only in their methods of applying the principle.

The Counterflex method is particularly adaptable to reflex circuits, although it can also be used in straight radio-frequency amplifying circuits. The method is illustrated in Figs. 1 and 2. Fig. 1 shows a typical reflex circuit incorporating the Counterflex method of controlling self-oscillation. In this circuit, if L_3 has a high enough impedance and is coupled closely enough to L_4 to produce good amplification, continuous oscillations will be self-generated in the circuits of the reflex tube when the tuned circuits are adjusted to any given frequency. These continuous oscillations

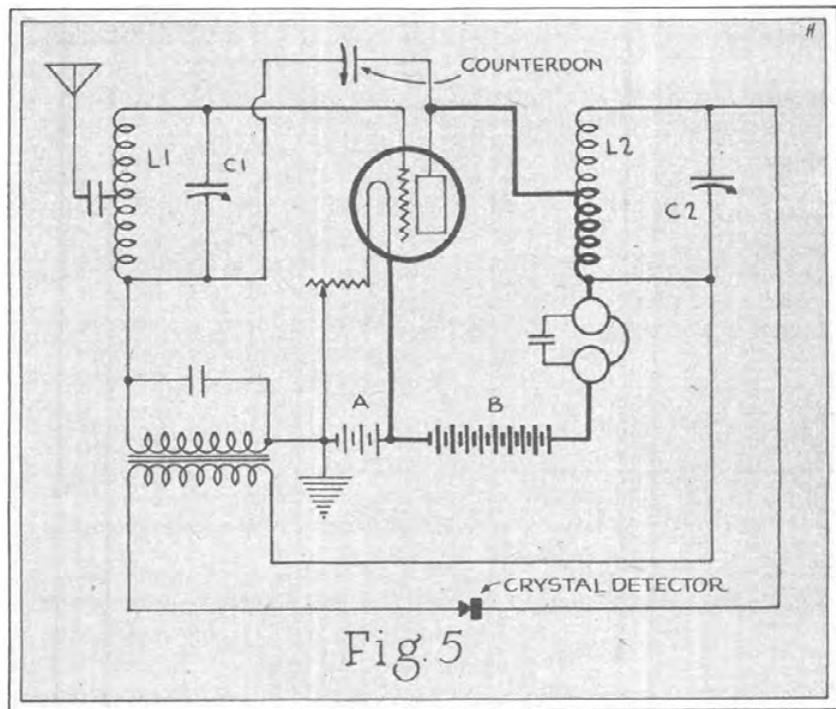

can be stopped by adjusting the capacity of the counteracting condenser C_1 .

Figs. 2A and 2B illustrate the functioning of the counteracting condenser in more detail. Fig. 2A shows the grid and plate circuits of the reflex tube of Fig. 1 apart from the remainder of the system. C_1 is the variable counteracting capacity. C_2 represents the capacity of the reflex audio-frequency transformer secondary and the fixed capacity shunted across it. C_3 represents the grid-plate capacity of the tube and C_4 the grid-filament capacity. In the plate circuit L_3 is the primary of the radio-frequency transformer, L_3 , L_4 and C_5 is the capacity of the telephones and by-pass condenser. Fig. 2B is exactly the same circuit as 2A. It demonstrates that the tube capacities (C_3 and C_4) and the capacities C_1 and C_2 form a Wheatstone bridge, which can be balanced by adjusting the capacity of the counteracting condenser C_1 . When the bridge is balanced the grid is not affected by oscillations in the plate circuit so that continuous oscillations cannot be generated. If the bridge is off balance, in either a posi-

tive or negative sense, the grid is proportionately affected by oscillations in the plate circuit and either regeneration or self-oscillation takes place, depending upon the extent to which the bridge is unbalanced.

It is important to note that a comparatively large counteracting capacity is needed at C_1 (especially in a reflex circuit) and that this capacity does not require a critical adjustment. This is one of the most important features of the Counterflex method. Nearly all other methods (including the Rice method, which is often erroneously confused with the Counterflex method) use an extremely small counteracting or neutralizing capacity (approximately the same capacity as the grid-plate capacity of the tube), and this capacity requires very critical adjustment. The slightest change in this capacity or in the tube capacity (which frequently takes place when the tubes in a set are changed) unbalances the system sufficiently to produce self-oscillation.

For this reason, in most receiving systems using other methods the neutralizing condenser is permanently adjusted and

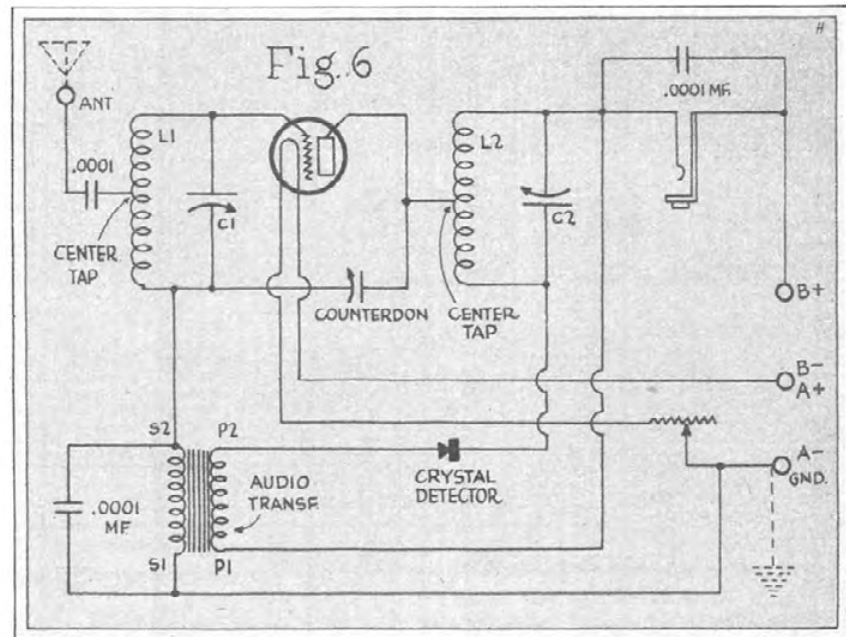

cannot be varied while operating the receiver, as it can be in the Counterflex. With these other methods the capacity values are so small and the adjustment of the neutralizing capacity is so critical that it is frequently impossible even to find a value which neutralizes at all frequencies covered by the receiver.

The Counterflex method is very simple in this respect. The counteracting condenser is quite large and is by no means critical in adjustment. The standard counteracting capacity designed for this circuit is a 3-plate condenser, the plates being almost as large as the average tuning condenser. The maximum capacity is about .00006 mfd. There is, of course, one value of this condenser which accurately balances the system, but this value must be considerably increased or decreased to produce self-oscillation.

For instance, using a standard counteracting capacity as described, and presuming that the values

(Continued on Page 25)

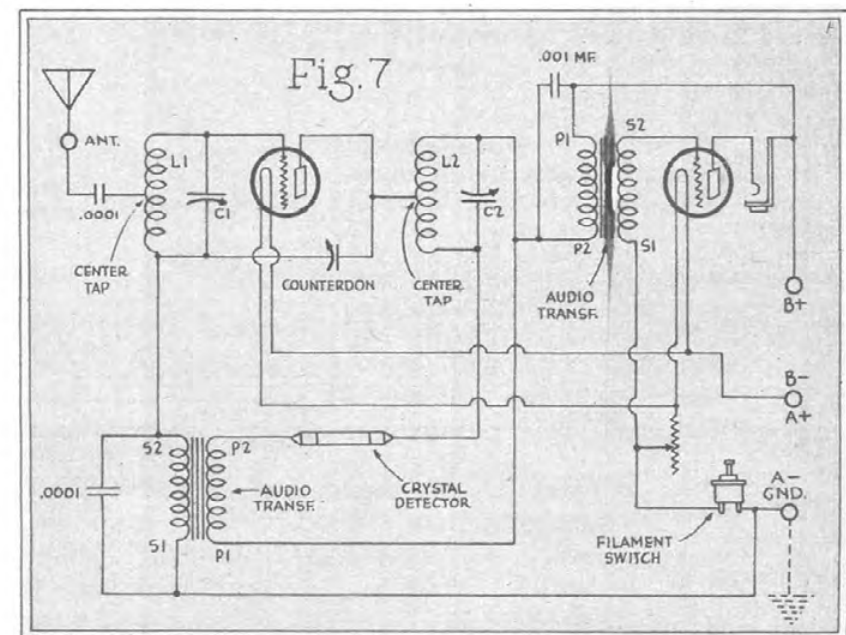

Let's Cut Out *those* Whistles!

By R. S. McBRIDE

Washington Representative of Radio in the Home

HOW would you like to be the traffic officer on an exceedingly busy corner at night if all the automobiles were running at high speed without lights and there were no street lighting? This is about the situation in which the director of radio traffic has been until lately; but fortunately radio engineers have erected rather an effective system of radio street lighting and now have devised for radio the equivalent of brilliant but "non-glare" headlights. As a result the future radio accidents are going to be caused only by the stupid or the reckless, just as most of the auto mishaps are.

The radio listener is the one who suffers when there is a traffic jam in the air or a collision of ether waves. As a matter of fact, with the present wave-length assignments, the occasion for traffic jams over most of our wave-length area has been reduced to a minimum. As listeners we are, therefore, now more worried by the collisions which evidence themselves in squeals and grunts or growls. And it is the frequency of these disturbances, which result from "heterodyning," that is causing the present criticism of the ten-kilocycle spacing and is creating the demand for fifteen-kilocycle intervals between stations. It is worth while, therefore, to dig down under the surface of this problem and see what the real facts are.

Two stations whose radiated waves reach a common point produce beat notes at that point. If the frequency of the two waves differs by less than five or six kilocycles the beat note produced is audible. The result is a disturbance in the loudspeaker or head phone, the pitch of which depends upon the difference in the frequency of the interfering waves.

If two stations are exactly on their assigned wave lengths, that is, ten kilocycles apart, the interference they produce cannot be heard, for the human ear does not detect such high frequency. But if each of the two strays a couple of kilocycles off the assigned frequency, they may then be separated by only six kilocycles, and the result is a very high-pitched continuous note. If the wandering from the straight and narrow way is more serious the interference gradually assumes a lower and lower tone, and the screeching of hyenas is replaced by the roar of the lion or perhaps a rumbling low-pitched tone that, if such a thing is possible, is worse. Until the difference of frequency gets as small as twenty cycles the tone remains audible and disturbing.

These aerial collisions are really inexcusable. Well developed and thoroughly proven apparatus which will enable the station operator to avoid creating any such disturbance is to be had at nominal cost. No less an authority than the National Bureau of Standards will vouch for this conclusion.

That institution has developed and made available to all broadcasters the de-



sign for a frequency indicator by which any man capable of operating a station at all can instantly determine whether he is on his assigned wave length or not. And, of course, all properly built stations have no difficulty in coming back to the proper frequency when their departure from the proper point has been detected.

The Second National Radio Conference, which met in 1923, recommended that all stations maintain their frequency within plus or minus two kilocycles of the assigned value. Any station operator who will claim that he cannot maintain the frequency he desires within half this, i. e., one kilocycle for broadcasting purposes, is not worthy of a license.

Hence no one can claim that those who have been guiding radio traffic in the past have made the traffic lanes unduly narrow. Now the excuse for straying is even less with the Bureau of Standards offering what might almost be called an automatic steering mechanism for the radio machine.

This device is a harmless looking little box about the size of a storage "A" battery. In the lid is mounted a simple indicating meter. When the Bureau has calibrated the device for a particular station the operator needs only to make sure that the pointer on this dial remains always at the highest possible point to know that his transmitter is correctly adjusted as to frequency.

The frequency indicator can be built from specifications furnished free by the Bureau by any radio instrument company or any skilled radio experimenter with parts that certainly would not cost more than \$25 or \$30. The market price as it becomes more widely used will probably be about \$100 complete with calibration guaranteed. Incidentally, this calibration costs the tremendous sum of \$5!

All worthwhile stations, which, of course, means all those of class B, take great pains to furnish their studios with every mechanical contrivance for perfect transmission and their reception rooms with artistic and comfortable fittings. It

is hard to understand, therefore, why the operating room, which is the vital mechanical center of the station, is so seldom equipped with an accurate calibrated frequency indicator. It does little good to have the best artists in a perfect studio with a powerful transmitting outfit if undetected wandering from the assigned frequency brings aerial collisions and hyena solos to the listener.

The alternative to prompt installation of such frequency-indicating devices and their regular use, is a wider frequency spacing between stations. The listener is really indifferent as to which alternative is taken. But the station operator can hardly be so disinterested, for if a fifteen-kilocycle spacing is the means finally adopted for elimination of this heterodyning, then more than one-third of the present Class B stations will either have to close or to move down out of the preferred wave-length area which they now enjoy into the congested district which is populated by 500 other stations, most of which are of Class A. Personally, if I owned a station, I know that I could not make haste half fast enough to suit me in getting and putting into use the very best frequency indicator that money could buy.

From the above discussion the reader must not infer that all broadcasters are happy-go-lucky wandering miscreants who ride the air at any wave length that may suit their fancy. There are, on the contrary, stations whose performance is exceptionally fine and Uncle Sam is recognizing some of these excellent performers in what could rightly be called a Radio Roll of Honor. This roll is made up of those stations which have been found by the Bureau of Standards to maintain a sufficiently constant frequency to be useful as frequency standards. Seven such stations with frequencies from the 950 kilocycles of KDKA to the 610 kilocycles of WEAJ are within the range of interest to the broadcast listener and are given on the latest available list from the Bureau. The other five "honor" pupils are WCAP, WRC, WSB, WGY and WBZ.

Of all the stations WEAJ has the finest record, for upon no occasion of measurement has the Bureau found that station as much as one-tenth of 1 per cent off its assigned frequency.

The Government does not make it necessary to depend even upon these well-operated stations for frequency comparisons, for the Bureau of Standards itself sends out from its station, WWV, and from Stanford University, station 6XBM, at bi-weekly intervals a series of signals that will permit any listener to calibrate his wave meter or his receiving set with the highest possible precision. Thus, operating engineers, manufacturing companies and amateurs, all can get a regular check on their equipment.

Still another effort of the Department of Commerce to insure proper maintenance



of frequency is being made through the radio-inspection service of the Department. The inspectors of each of the nine districts are being supplied just at the present time with improved instruments and new standards for this purpose. In the old days, a decremeter was employed to determine the variation from desired frequency of the spark sets commonly used on ship board. These decremeters are now being sent in to the Bureau of Standards for remodeling and recalibration, so that each inspection district will have an instrument that will certainly be correct in its indications within one kilocycle.

To insure that the apparatus remains in calibration, each district will also be supplied with a new type of Piezo-electric oscillator which will really serve as its fun-

time than the directors of automobile traffic because the ether wave is intangible and travels everywhere and its vagaries are many and little understood. But in one respect the radio inspector has an easy time ahead of him now that first-class equipment and dependable testing methods are available. He need only go to his own inspection laboratory and sit there in comfort while he manipulates the testing instruments to determine whether all the broadcasters in his district are keeping properly in bounds.

When a station is on the air at all, it is automatically furnishing a sample of its transmitted wave right at the inspector's instruments ready for his test. There is no chance, therefore, for the culprit long to escape the vigilant inspector's ear. Dis-

tion, the transmitting station itself produces distortion; and then there is no hope that a receiving set can pick up the original music with true quality.

For this, if for no other, reason a spacing of seven and a half kilocycles, which was experimentally attempted a few months ago, was doomed to failure even before the tests began. But from those tests the Government specialists will not agree that there is any indication of the necessity for a greater than ten-kilocycle separation — *provided, of course, each broadcaster does a good job of operating.* These experts still believe that the report of the engineers at the Third National Radio Conference in October, 1924, recommending ten-kilocycle spacing, gave adequate protection against any aerial confusion

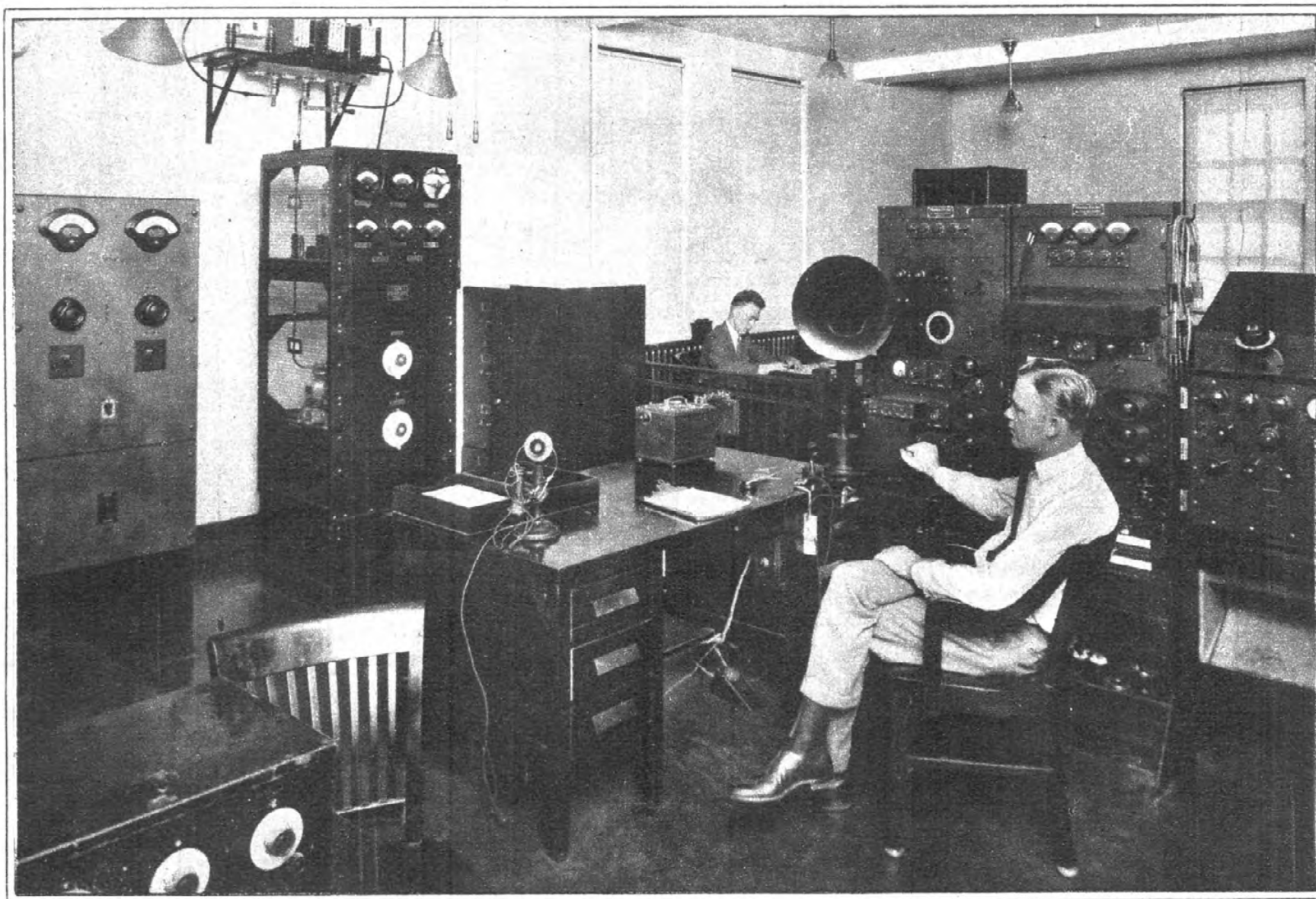

*Operating room of Station WCAP,
Washington, D. C.*

The frequency indicator is the box on the right-hand far corner of the table in front of the operator

damental frequency standard. The vital part of this instrument is simply a carefully prepared disc of quartz cut from a quartz crystal. This material has the property of responding to electrical vibrations at certain definite frequencies and it can, therefore, be used to test the frequency meter and thus insure that the adjustment has not changed since calibration. Each inspection office will keep this quartz oscillator, much as a weights and measures inspector keeps his shiny gold-plated weights in a plush-lined box, simply as a reference instrument to which the common working meters can be compared from time to time to make sure that every-day use has not resulted in any discrepancy in their indications. In some ways the radio inspectors of the Government have a harder

cussing the fundamentals of radio interference, the radio engineers of the Bureau of Standards make very clear why it is that the ten-kilocycle separation between assigned frequencies for stations is the closest spacing which will ever be practicable. No matter how accurately two stations may run their apparatus, they find it necessary to produce modulations of five kilocycles above and below the basic frequency in order to accommodate all kinds of speech and music. If it is attempted to work within a narrower range of modula-

due to too close a placing of stations on the aerial wave-length area.

"Blanketing" of one station by another more powerful nearby station is not a matter which can be controlled by the broadcaster; the listener has to care for this problem almost altogether for himself. But the radio experts who are studying every possible angle of radio technology feel that the time is near at hand when the average listener with moderate investment can do this without difficulty. This will be accomplished by using either a wave trap in combination with a moderately selective set or a highly selective set such as the superheterodyne. Either combination is good, of course assuming proper design, unless one is so unfortunate as to live within a mile or

(Continued on Page 24)

Now Women Demand their Share of Programs

By
ELIZABETH HALLAM BOHN
Instructor, Home Management, New York University

MORE and more, women are demanding their fair share of the material broadcast from their favorite stations. Women, be it added, are much the better audience also because they will take the trouble to write to the broadcaster saying what they like and what they do not. This is of immense value to the men in charge of making programs.

Considerably over 100,000 have written to Elizabeth Hallam Bohn since she started broadcasting her little five-minute rice recipe during the concert by the B. Fisher Company Astor Coffee Orchestra. Miss Bohn has now inaugurated a weekly hour for housewives during the morning from station WEA-F, and this is proving just as popular as did her rice talks.

Not long ago, Miss Bohn used as the topic for one of her talks the modern scientific way of taking the drudgery out of the household task of dishwashing. The talk proved tremendously popular. She was literally deluged with letters from women listeners who did not quite understand some of the details.

Miss Bohn then realized that a talk of this kind could be made immensely more valuable to her women listeners if only she could show them by pictures or actual example just what she meant by the various utensils and how they are used. She spoke to me about this one time when I was with her in New York, and it immediately occurred to me that thousands of women who read this magazine would probably appreciate a "3XP style wire-up" of Miss Bohn's most popular talk of the month so that they themselves could actually put the process into operation just as their husbands or brothers or sons put into operation our instructions for wiring up radio sets by means of this same kind of step-by-step pictures.

On the next two pages will be found the photographs giving the "3XP style wire-ups" of how to wash the dishes. Each month Miss Bohn will furnish us with material of this kind on her most popular talk. Hand this to your wife and ask her what she thinks of it.

Following is the lecture which Miss Bohn gave from WEA-F:

THE eternal woman manifests itself in us constantly. One of its earmarks, most easily discerned in those who disclaim all things feminine, is the characteristic query, "But, my dear, how did you ever accomplish such wonders?"

As our Indian sister guards the story of the exquisite colorings in the rugs she has wrought, even so it with some of us fondly to cherish the secrets of any success we have achieved in our home-making.

In the Home Economics Department of a great metropolitan university, a group of women trained in scientific home-making and management, unlike many of their sisters, thrive on passing on all of the little aids and devices which will lighten the irksome duties of those engaged in home-making. They have taken for their motto, "Come out of the kitchen!" Their program consists of experiments made to discover the easiest way of performing household tasks so as to prevent waste of time, strength, money and materials. Recently, they selected the task that housewives detest most—dishwashing—and set to work



ELIZABETH HALLAM BOHN

to eliminate some of its disagreeable features. Let me take you into their workshop. Let us ask them, "My dear, how did you ever accomplish such wonders?"

Here are some of the interesting and helpful things they discovered about dishwashing:

By rearranging your equipment, purchasing additional utensils and changing the order of your work, you can reduce the time spent and the motions made, and convert this unpopular home task almost into a science.

Starting with the sink, add a roomy, enameled dishpan, a dish drainer and rinsing pan combined, dishcloth, dish towels, soap shaker, metal dishcloth, dish mop, steel wool, sink brush and rubber plate scraper. The last four utensils will cost you only ten cents each and will prove their worth many times over. Keep your sal soda, soap, scouring powder, steel wool and a large

cork on a shelf above the sink. The dishwashing moves faster if one cleans up as much as possible during the preparation of the meal. It is pleasanter, too, if one does not have to wash the greasy pots and pans after all the table dishes have been finished.

Soak in cold water the pans in which eggs, milk and flour have been cooked, and in hot water the utensils which have contained sugar or fat mixtures. Before washing the frying pan and the heavier kitchenware, wipe them out with paper and soak them in a solution of hot water and sal soda to dissolve the grease. Steel wool with a little white soap is splendid for removing stains from agate ware, enamel ware, aluminum ware or glassware. Aluminum can be kept shiny and clean by rubbing it with steel wool; cutlery and glass need a gritty scouring powder applied with a cork.

The secret of caring for all utensils, and especially those made of aluminum, lies in

3XP Style Wire-Ups of

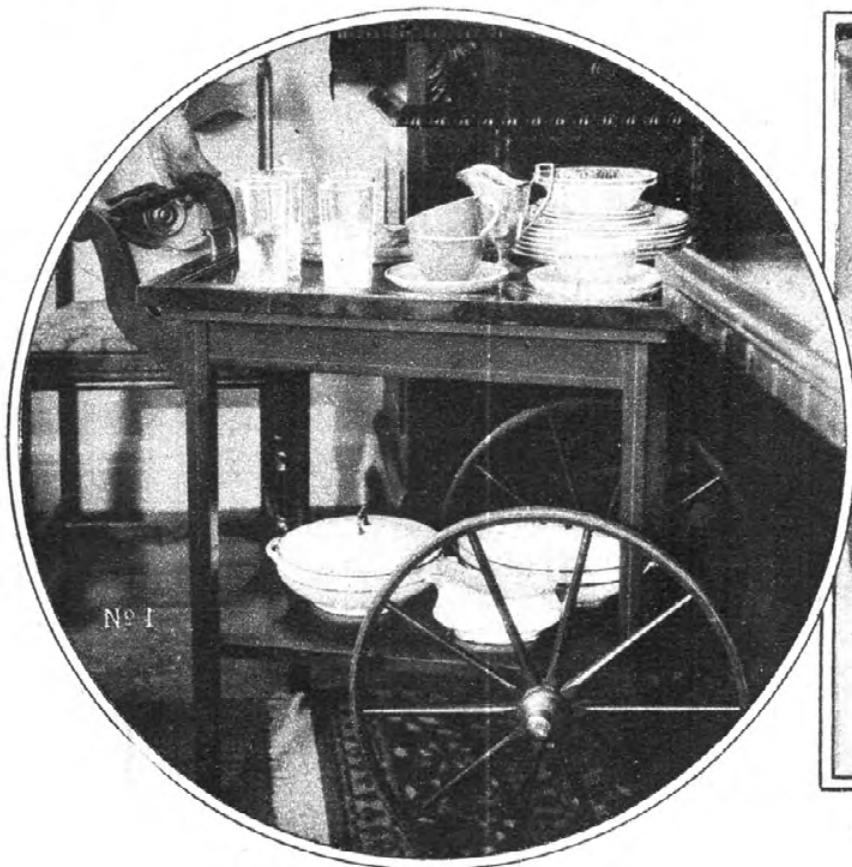

No. 1.—Dishwashing really begins in the dining room with the clearing of the table

No. 2—Proper dishwashing equipment simplifies work. Soap shaker, metal dish-cloth, plate scraper and sink brush from the ten-cent store

No. 3—Put soap in hot water, stirring with soap shaker to make good suds.

No. 4—Wash all glassware, using a little soap to give it a bright polish

prevention. We should not allow our food to burn while cooking, but if it does burn, we should clean the utensil thoroughly and wash it immediately.

Dishwashing really begins in the dining room with the clearing of the table. A wheel tray is invaluable for removing soiled dishes. After each meal, roll it close to the dining-room table; then, putting the silver on one empty dish, scrape the soiled plates with the plate scraper, and pile the china each size and kind by itself on the tray. Then wheel it out to the kitchen sink. First

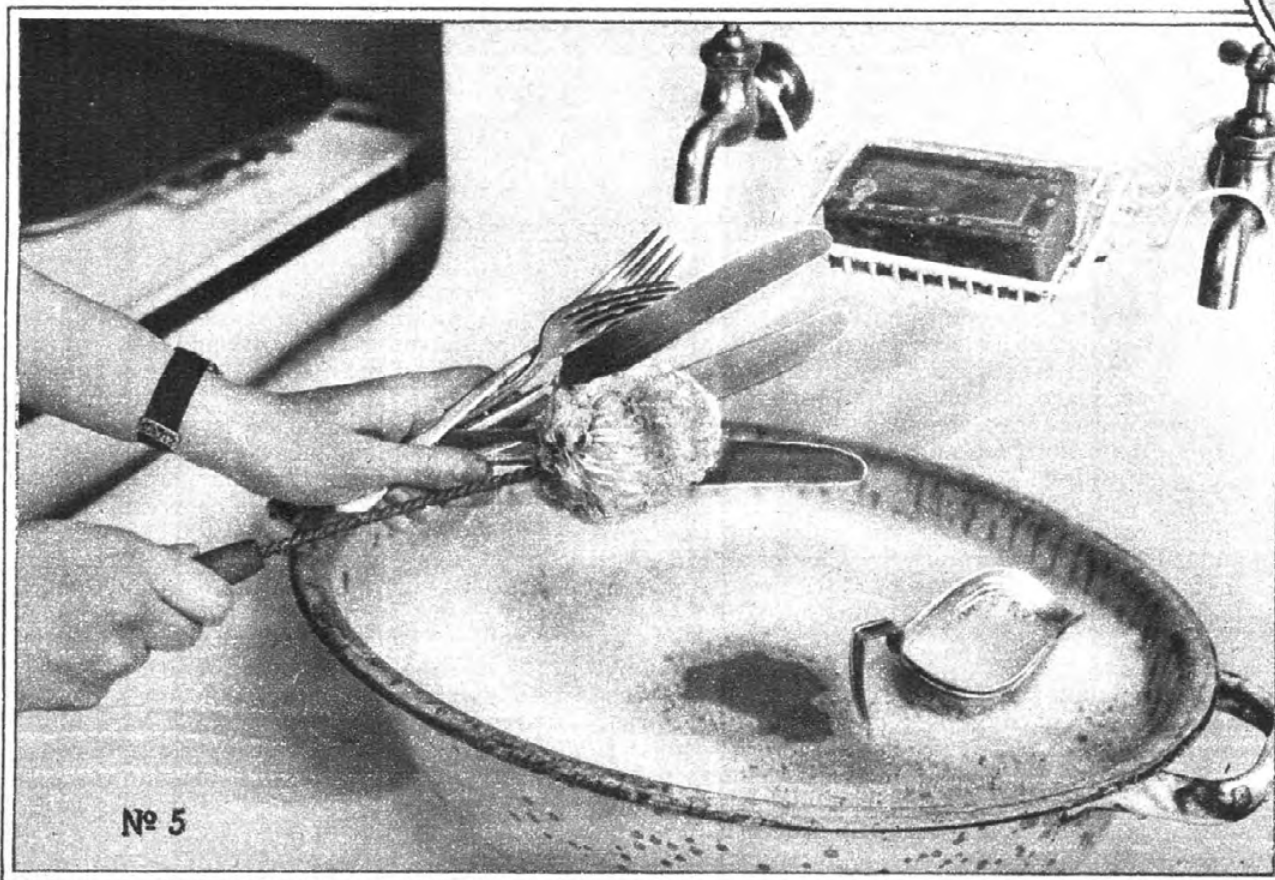
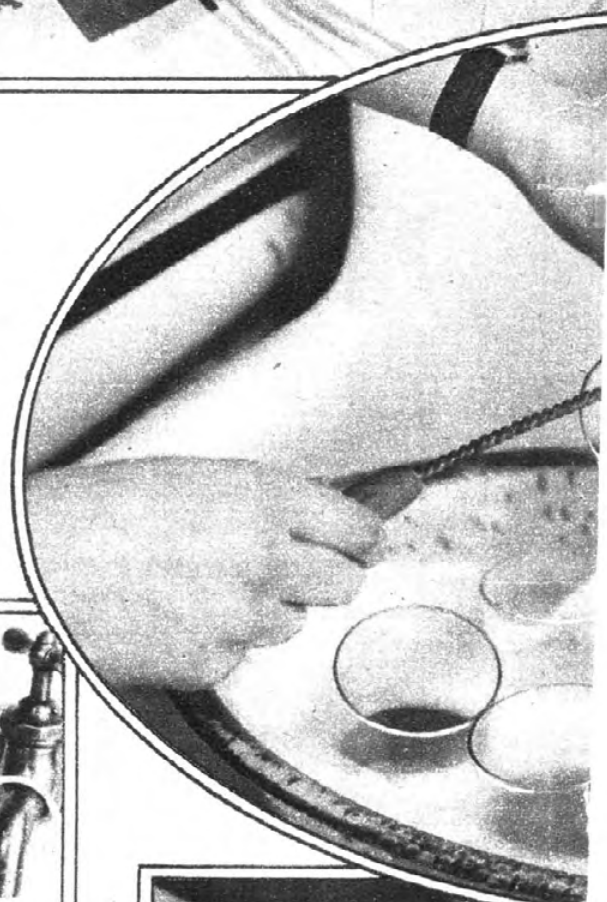

How to Wash the Dishes

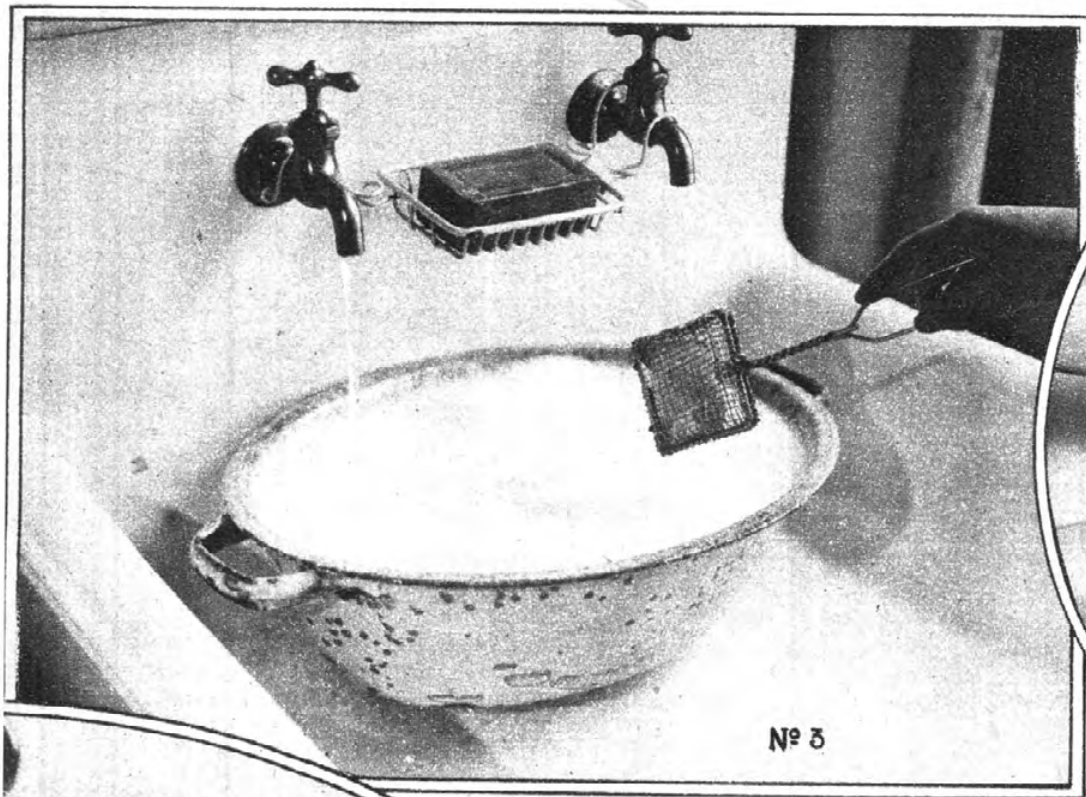

No. 3

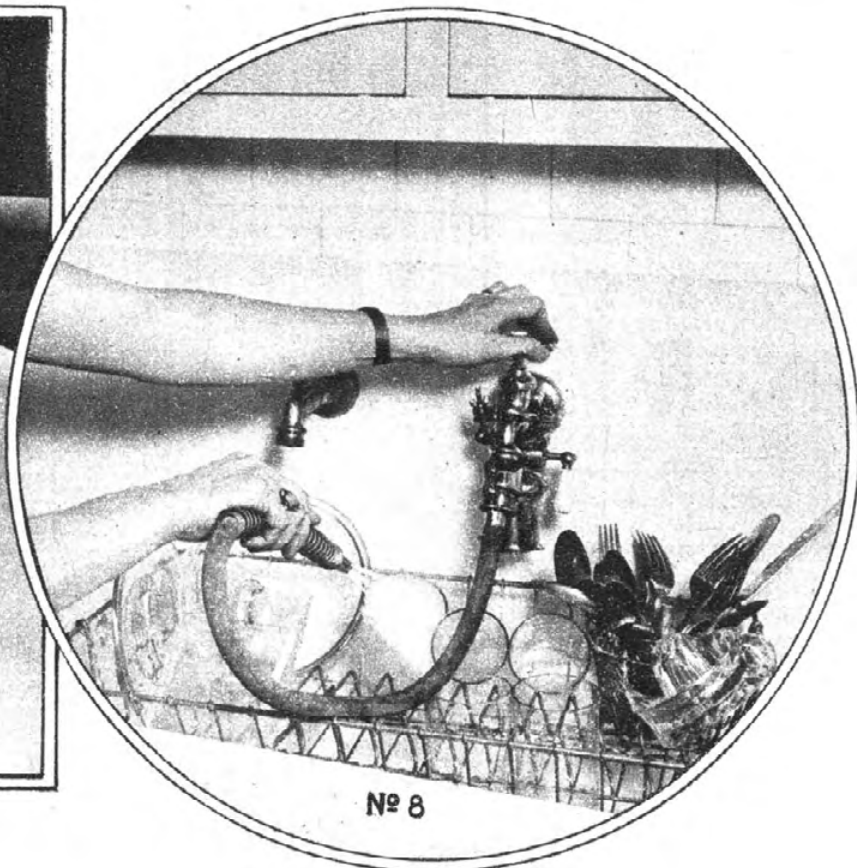

No. 8

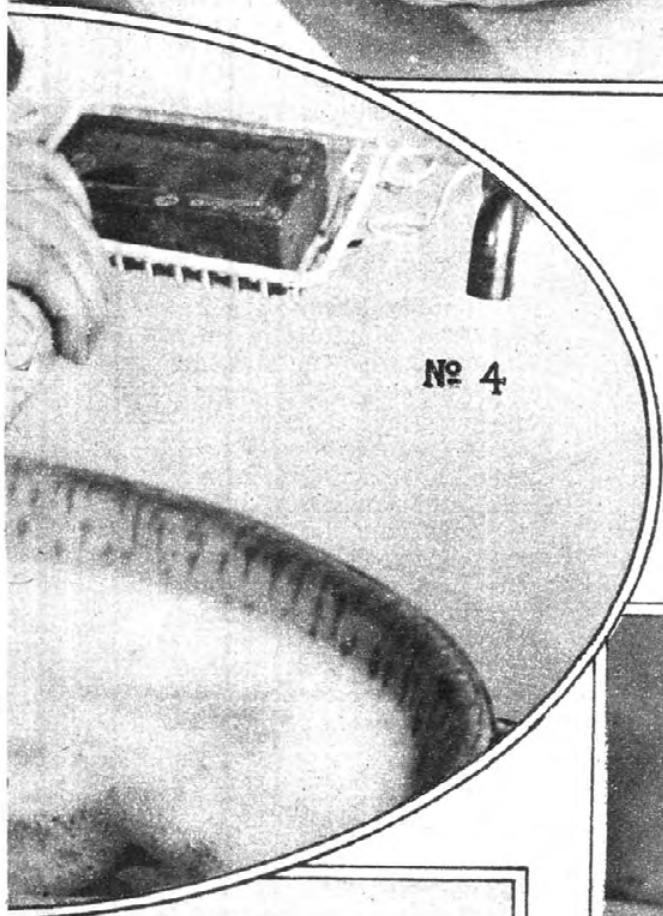

No. 4

remove the glass dishes, and if they have been used for anything but water rinse them. Then sort the silver, putting the knives, forks and spoons in different piles. After that, rinse the china dishes again, and sort them, arranging them in piles once more. After this preliminary work, wipe off your drainboard so as to have a place for the clean dishes. If you wash dishes with a dish mop, you may use very hot water into which soap flakes or a shaker filled with small bits

(Continued on Page 28)

No. 5—Wash the silver next and place it in the wire basket

No. 6—Then wash the china carefully using a dish mop to keep your hands out of hot water

No. 7—Place the dishes in the wire drain, scald them with plenty of hot water and allow them to dry

No. 8—This new nonelectrical dishwashing device may be used on any faucet. The dishes are washed, rinsed and allowed to dry in the drain basket without touching the hands to the water

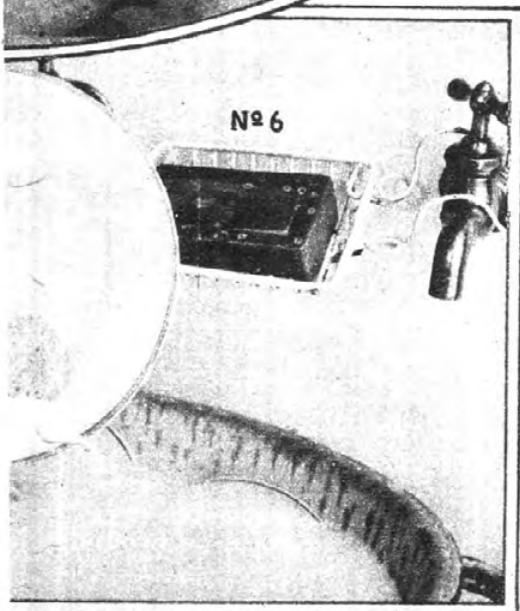

No. 6

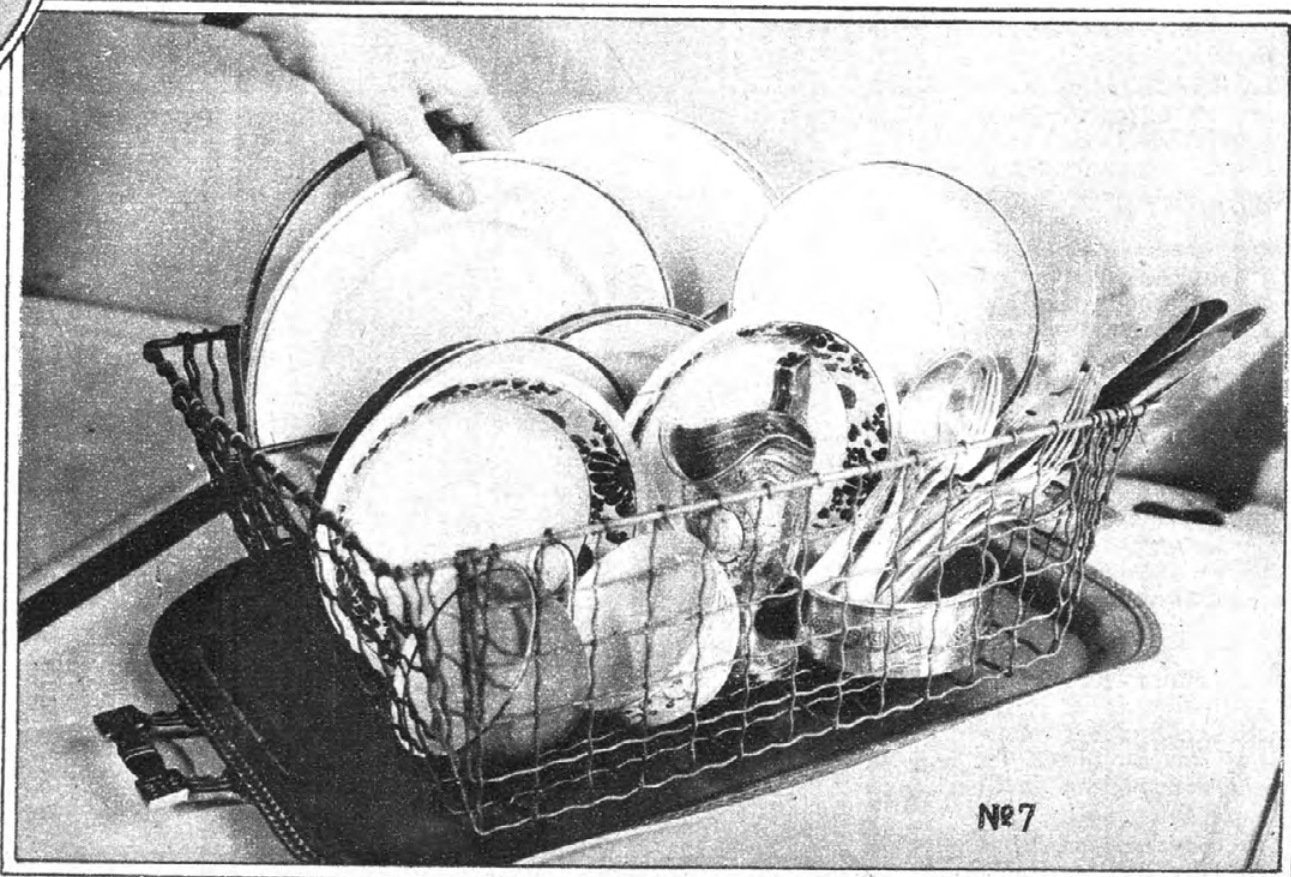

No. 7

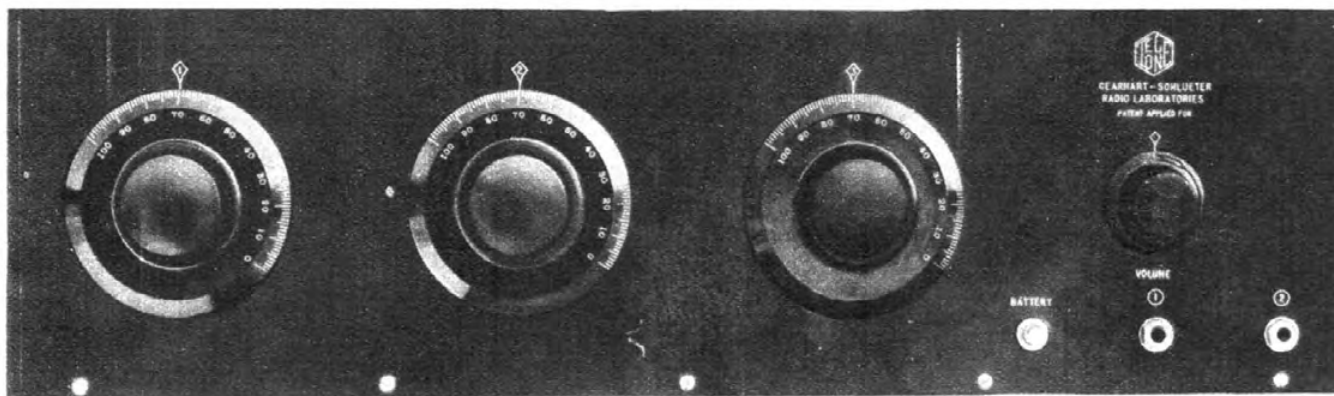

How to Make the New Quadraformer Receiver

NOTE: Permission is granted to the readers of "Radio in the Home" to use these circuits, diagrams and instructions for experimental use only. All the improvements described by Mr. Gearhart in this, and succeeding articles, are being protected by patents pending. Their use without authority would constitute infringement.

PART II

IN THE May issue of *Radio in the Home*, I told something of the theory behind the development of the Quadraformer tuned radio-frequency transformer, and how the set of three necessary Quadraformers for a two-stage radio-frequency amplifier could be made at home by the advanced experimenter.

For the benefit of those readers who do not care to spend the time and careful labor necessary to make their own Quadraformers, there is now on the market a kit of three Quadraformers together with a most complete step-by-step instruction book describing their use in a powerful five-tube set. Fig. 1 shows the design of the commercial transformer.

The development of the Quadraformer started over a year and a half ago, when we began our search for a practical non-oscillating radio-frequency amplifier without the disadvantages of the known methods of introducing resistances or other losses into the circuits to stop self-oscillation.

Early in our experiments we discovered that if we could do away with magnetic coupling and still design an efficient transformer, our problem would be solved. The Quadraformer is the result.

Since several manufacturers are now advocating various designs of toroidal transformers (which the Quadraformer is *not*), with claims of results closely paralleling those you will get with the Quadraformer, it might be of interest to tell you why we discarded the toroidal idea nearly a year ago.

In our early experiments we naturally turned first to the to-

By E. J. GEARHART
Of the Gearhart-Schlueter Radio Corporation

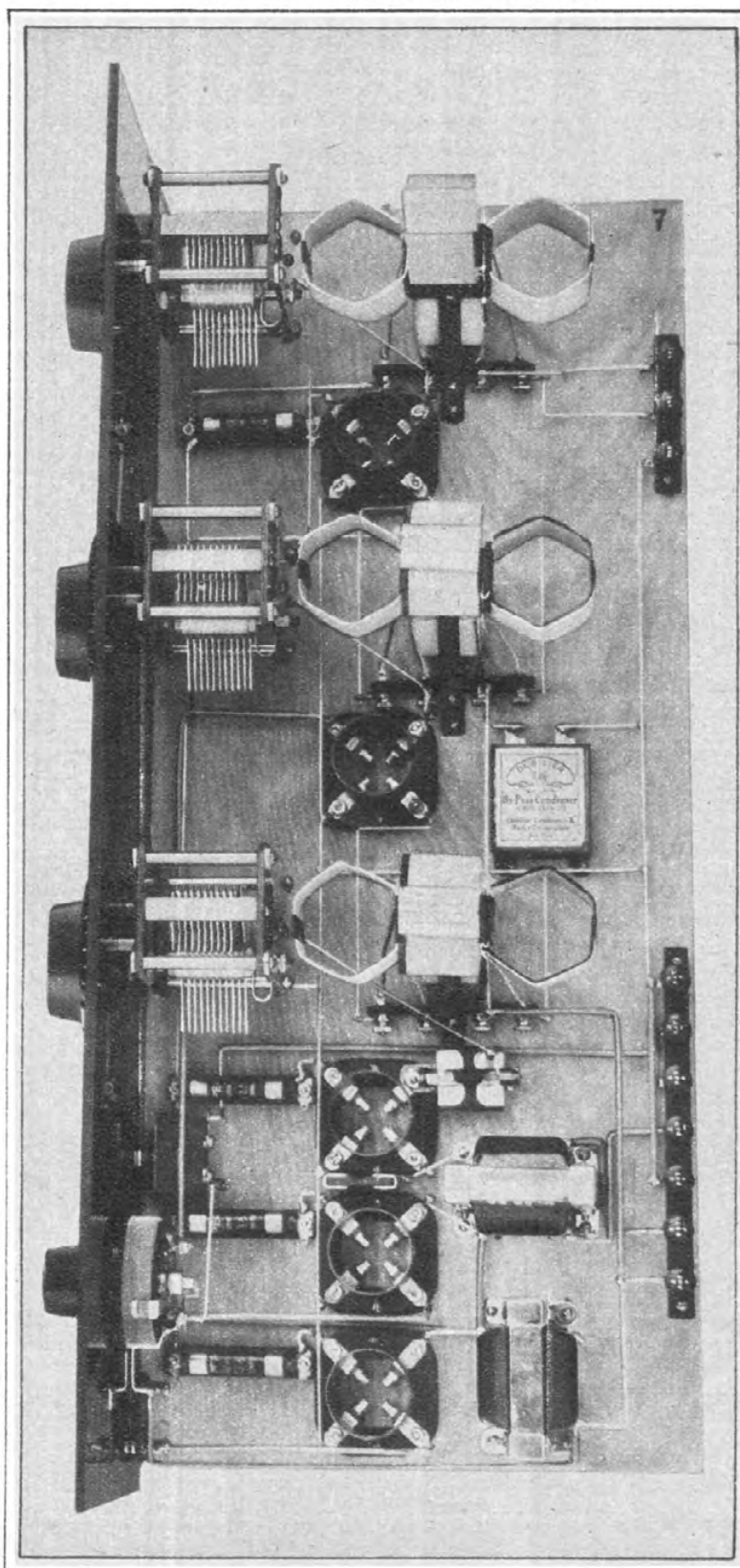

roidal idea, for it is the oldest known method of constructing a coil with a closed magnetic field.

I have before me, as I write, a text book of the International Library of Technology No. 383, published by the International Textbook Company of Scranton, copyright in 1925, in which, on Page 13 of the chapter on "Direct Current Generators" is shown a "ring winding" described as:

"The winding is a continuous spiral . . . all the flux, except a few stray lines, follows the ring between adjacent poles."

And again in *Radio*, a magazine published in San Francisco, for November, 1923, Page 25, is shown two illustrations of toroidal coils, with the statement:

"To confine the magnetic effects of a coil it is necessary to reduce its stray field. Even though two coils may be at right angles there may be some magnetic induction due to stray fields. To avoid this it is necessary to use certain types of coils called 'toroidal' coils. There is practically no magnetic field from such a coil, the entire field being confined within its core."

It is nothing new; in fact, it is probably the oldest known type of closed magnetic field coil.

Mr. Schlueter and I introduced the idea to practice and designed a toroidal radio-transformer, with primary and secondary windings, over a year ago—and then discarded it in favor of the Quadraformer type.

In the May issue, Mr. Neely described a Quadraformer receiver with resistance-coupled audio-amplification. Now, personally, I don't say that resistance coupling is any better or any worse than the use of good audio-transformers, but knowing that many experimenters are, like myself,

Fig. 7 (to the left) is the completed Quadraformer receiver. At the top of the page is Fig. 5, which shows the control arrangements on the panel

perfectly satisfied with the results obtained from good audio-transformers, I will describe this month my favorite set:

Five 201A tubes, two of radio, detector and two stages of audio.

Fig. 2 shows the wiring diagram, and Fig. 3 a drawing to scale of the wired set. These two drawings make the construction of the set almost an automatic one if carefully followed.

The following parts are necessary:

- 1 Quadraformer kit, consisting of antenna coupler and two interstage transformers.
- 1 Front panel of bakelite, 3-16 x 7 x 24.
- 1 Baseboard, 9 $\frac{3}{4}$ x 23.
- 3 Low-loss .0005 mfd. condensers with dials.
- 1 20-ohm rheostat.
- 1 Single-circuit small-space jack.
- 1 Closed-circuit small-space jack.
- 1 "A" battery switch.
- 4 1A Amperites with mountings.
- 5 Sockets.
- 2 Audio-transformers (any good make and any favorite ratio).
- 1 .002 mfd. fixed condenser (Dubilier, Freshman or Sangamo).
- 1 .00025 mfd. fixed grid condenser with leak clips (same as above).
- 1 5 megohm Daven or Durham grid leak.
- 1 .5 mfd. by-pass condenser (any standard make).
- 10 Engraved Eby binding posts.
- 2 Binding post mounting strips, as shown, necessary screws, soldering lugs, wire, etc.

Fig. 4 shows the back of the front panel with the three variable condensers, the rheostat, jacks and battery switch properly mounted. No panel layout is given because various makes of instruments require different mounting holes. The center holes for the three condensers

Fig. 2. Wiring diagram of the Quadraformer receiver

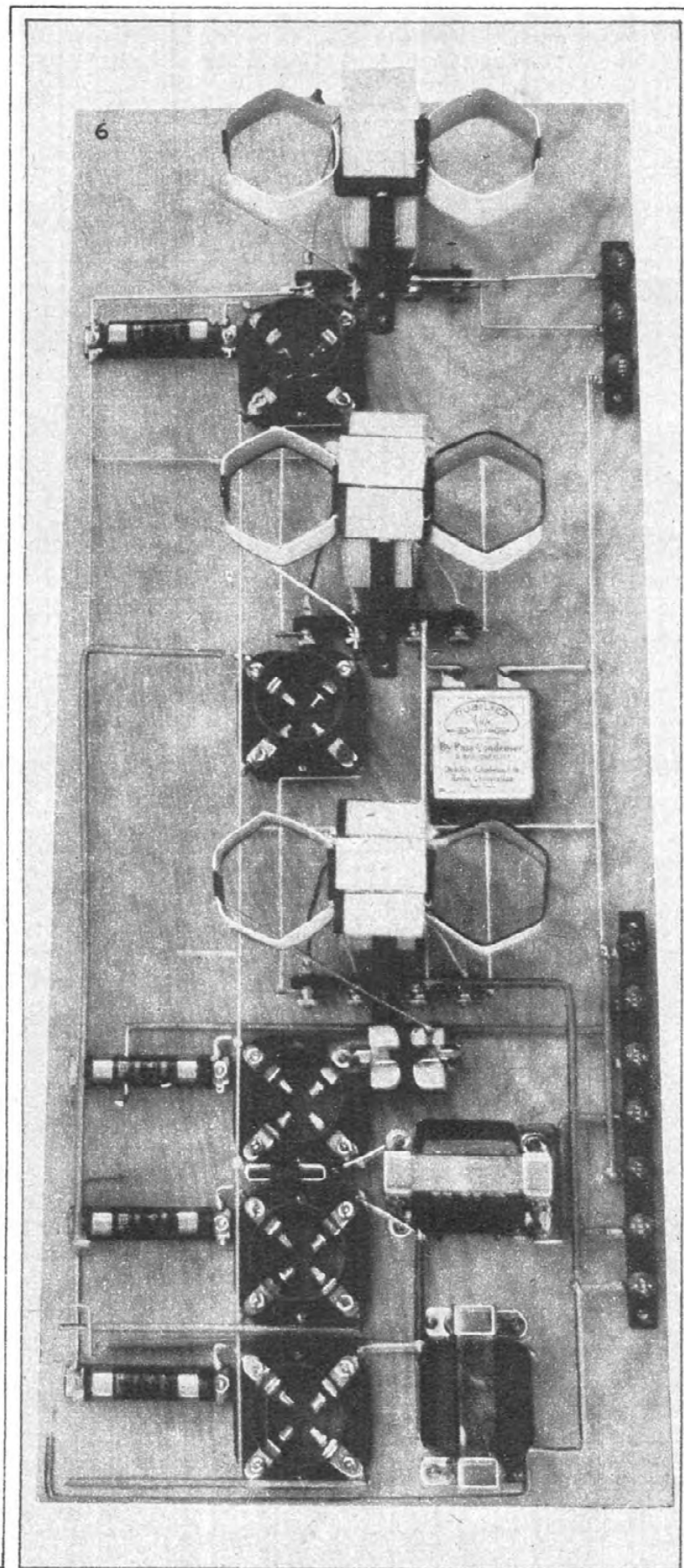

and the rheostat are six inches apart, midway between the top and bottom of the panel. If you will lay out your panel on a piece of paper the exact size of the panel, locating the shaft holes first, and then making use of the templates that are furnished with all good instruments you should have little difficulty in properly planning your panel.

Fig. 5 shows a view of the front of the panel, with instruments mounted and dials in place.

Lay out your instruments on the baseboard as shown in Fig. 3 and in the photograph Fig. 6.

Now screw the front panel temporarily to the baseboard to see if all instruments clear each other. Note that the battery switch just fits in between two of the Amperites.

When sure that all the instruments are properly placed, screw them firmly to the base and remove the front panel to make the wiring of the instruments on the base easier.

The two Jefferson audio-transformers shown are mounted by reversing the mounting feet, which brings the soldering terminals close to the base and shortens the plate and grid leads considerably.

Mount the grid leak and condenser, as shown, using a short piece of stiff buss wire or a small angle bracket.

You should now be ready to wire the set.

Please do not use hard-drawn buss wire. Use Celatsite wire, or plain No. 14 soft-drawn tinned copper and spaghetti. Be sparing of the spaghetti. We used three lengths.

Now following Fig. 2 or 3, or both, as you prefer, start wiring the filament leads first. Note that one wire connects one side of all the Amperites, and also the filament terminals of the antenna coupler and the first interstage transformer.

If your Quadraformers are

Fig. 6 (to the left) gives a very good arrangement of parts to be mounted on the baseboard

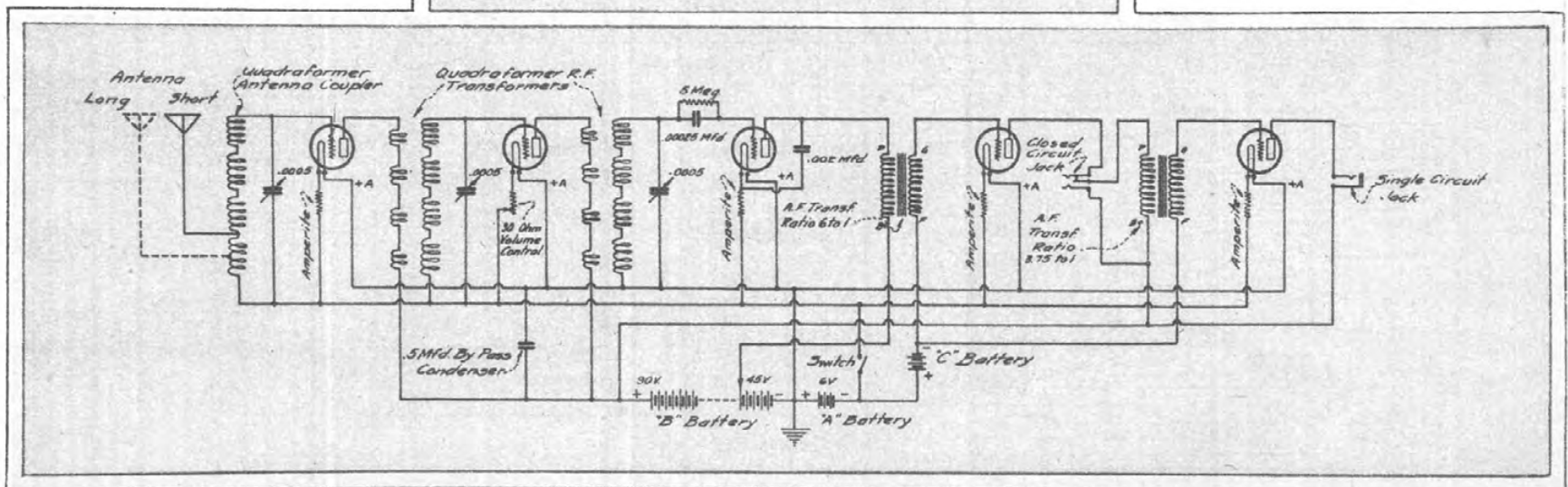

home-made, stop right here and check your binding posts: They will work only one way: The beginning of the winding on the antenna coupler goes to negative filament. The tap on this first coil goes to one aerial post for great selectivity. The other aerial post is connected to the end of coil No. 1 (between coil No. 1 and coil No. 2). The end of the fourth coil (and also of the winding) goes to the grid.

The terminals of the interstage transformers are as follows:

First Stage: The beginning of the secondary (from coil No. 1) goes to the grid. The beginning of the primary (also from coil No. 1) goes to the B plus terminal. Be sure of that. The end of the secondary (from coil No. 4) goes to negative A, and the end of the primary (also from coil No. 4) goes to the plate. Note that the filament

return of both the antenna coupler and the first-stage transformer goes to the negative filament battery lead, and *not* to the filament terminal of the tube sockets.

Second Stage: Just like the first stage, except that the filament return is connected to the "A" battery positive lead instead of to the negative. The commercial Quadra-

formers have properly engraved binding posts so that there can be no mistake. Another long lead connects all the positive terminals of the sockets together and the filament return of the second stage Quadraformer. Please note that one side of the .5 mfd. by-pass condenser, the B battery negative, and the ground connection all go to A positive. This is important.

Finish up the filament connections, wire in the antenna and ground leads, all grid leads and all plate leads. If you carefully follow Figs. 2 and 3 you should make no mistakes.

Screw the front panel to the base. Connect the battery switch, the jacks and the rheostat in the order named. Then connect the variable condensers. It's a mighty good idea to use flexible wire in making leads from the front panel to instruments on the base, then, if you pick the set up by the front panel you are not so apt to break any connections. Use soft-drawn No. 18 and

(Continued on Page 22)

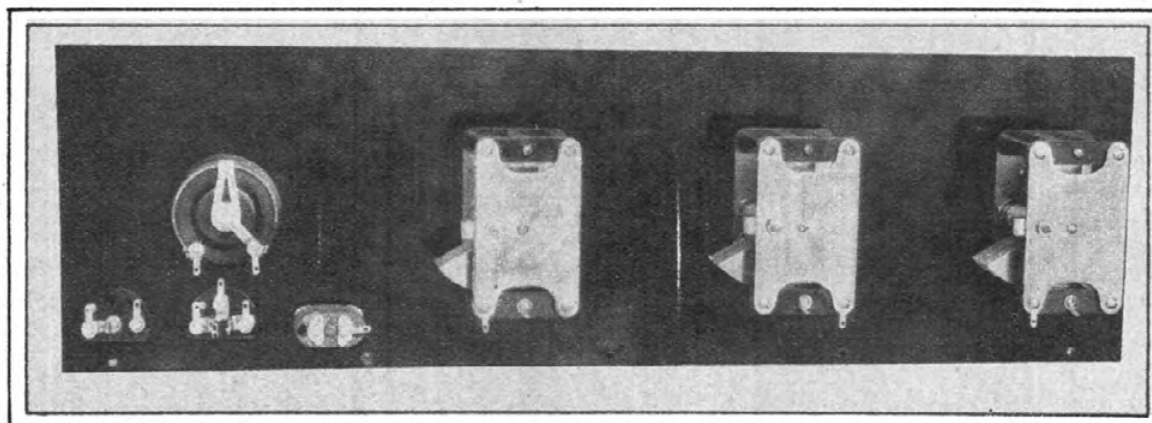
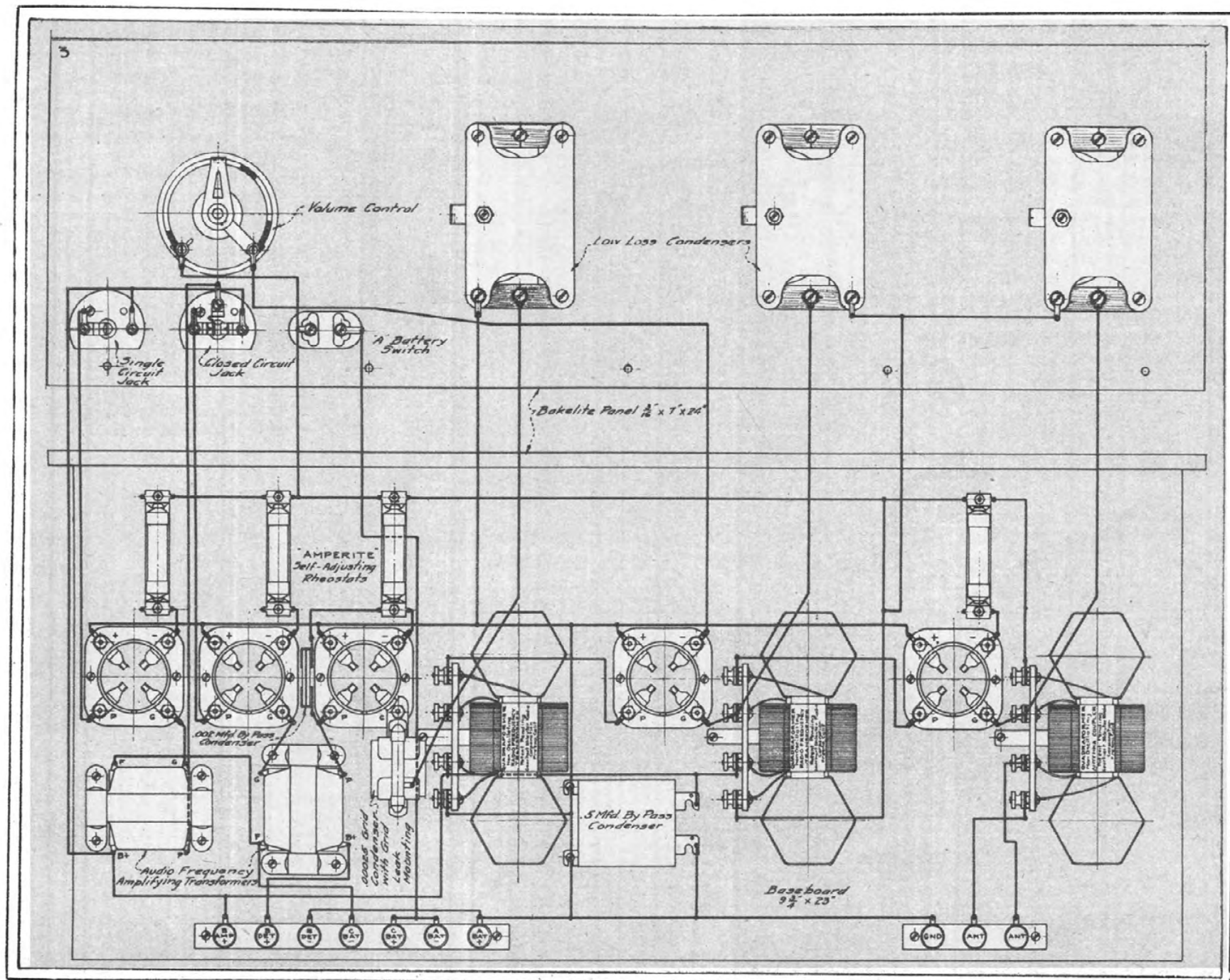

Fig. 4 (above) portrays the parts arrangement on the back of the panel
Fig. 3 is a wiring diagram of the Quadraformer receiver



The Superspeaker

THROUGH the ether there will come to you some time a Voice. A Voice of Friendship—A Voice of Romance. Be ready with a Jewett Superspeaker to catch every revealing inflection of living, breathing, human Personality!

The Superspeaker horn is non-metallic, and is therefore absolutely free from discordant harmonic vibrations.

"THERE IS NO SUBSTITUTE
FOR THE BEST"

JEWETT RADIO & PHONOGRAPH COMPANY
5682 TELEGRAPH ROAD PONTIAC, MICHIGAN

Factories: Allegan, Michigan—Detroit, Michigan—Pontiac, Michigan

Canadian Sales Offices: Walkerville, Ontario

Export Sales Offices: 116 Broad Street, New York City

The Jewett Superspeaker—All that the name implies. Recommended by experts everywhere. Price \$30.00.

The Jewett Vemco Unit—Makes a loud speaker out of your phonograph. The Reproducer used in the Superspeaker. Price \$12.00.

The Jewett Micro-Dial—Makes tuning 50 times as accurate. Fits any set. Needs only a screwdriver to install. Price \$3.50.

The Jewett Parkay Cabinet—With parquetry top. Puts the amateur on a par with the most exclusive cabinet worker. All sizes, prices to correspond.

The Jewett Superspeaker Highboy—Houses Radio set and all batteries. Superspeaker built in. Takes Radio into the realm of fine furniture. Price \$130.00.



JEWETT QUALITY PRODUCTS



Natural

Not only is Rauland-Lyric an instrument of superb amplification, but through skillful design it goes far in compensating for imperfections in the loudspeaker. Thus is reproduced in your home the beauty of actual tones as they are created in the broadcasting studio—pure, flawless, natural.

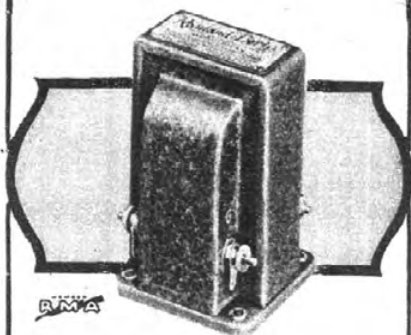

Rauland-Lyric is a laboratory-grade audio transformer designed especially for music lovers. Descriptive circular with amplification curve will be mailed promptly on request. All-American Radio Corporation, 2666 Coyne St., Chicago.

The price is nine dollars



The Choice of Noted Music Critics

How to Make the New Quadraformer Receiver

(Continued From Page 20)

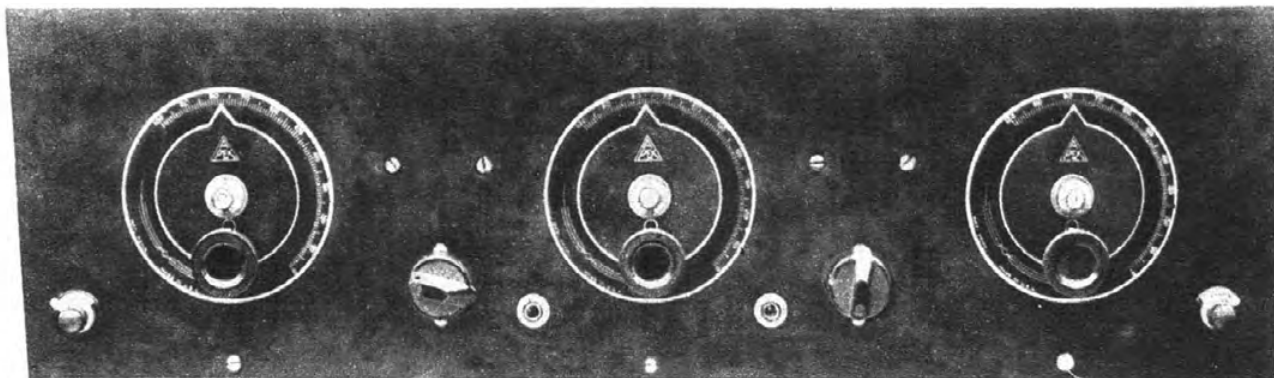

spaghetti. Use soldering wherever possible, instead of trusting to a loop in the wire under a binding post. Funny how they will loosen up, but they do.

The drawings and photographs are so plain I haven't taken the space to give you wire for wire instructions. Check your work often against Figs. 2 and 3.

When you're all done, take a hint from me and connect your "A" battery to the "B" battery binding posts, put a tube in each socket. If any of them lights you've got a short circuit somewhere, which you'd better find before going further. If none lights, disconnect the "A" battery, take out the tubes and connect the "A" battery to its proper binding posts. Connect the "C" battery and "B" battery. If you still have the metal base 201As use 45 of 67½ volts on the detector, but if your detector is one of the new bakelite base tubes you will probably find 22½ volts best. Try 67½ and 90 volts, or more, on the high-voltage binding post.

Now to be doubly sure take just one tube and try it out in each socket with the battery switch on and the volume control turned about three-quarters on. If the tube burns properly in each socket, you're safe in inserting all tubes and tuning in your first station, after connecting aerial and ground to the proper binding posts.

If you have ever tuned a neodyne, you will have no difficulty in tuning your Quadraformer receiver, as the operation is exactly the same.

Assuming that the batteries, antenna and ground have been connected, and that the tubes have been placed in their sock-

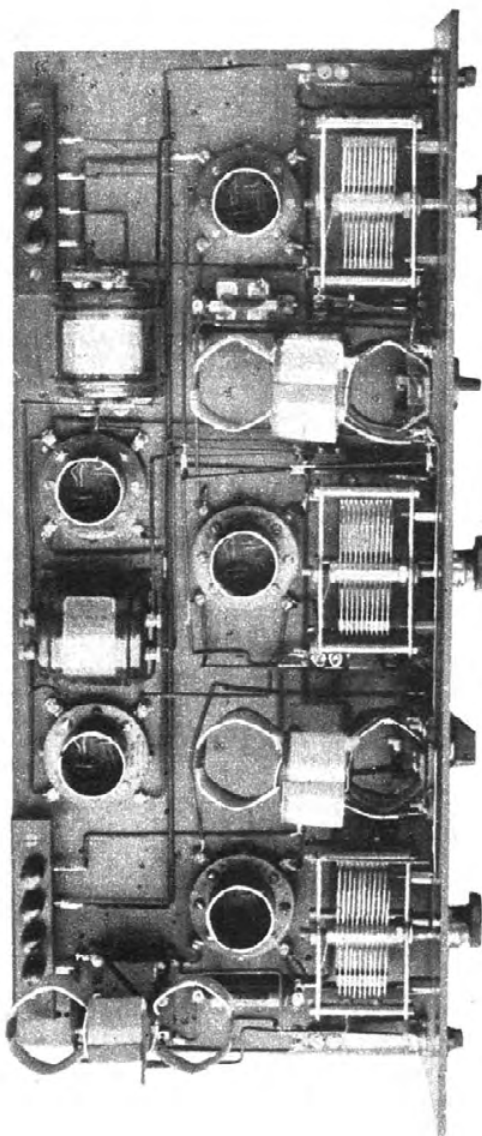

ets, the horn or phones plugged in, set the volume control (which is the rheostat on the second radio-frequency stage) approximately three-quarters of a revolution in a clockwise direction and snap the battery switch on.

Set dials No. 2 and No. 3 at any low number, say 15 degrees. Then rotate dial No. 1 slowly from 10 degrees above to 10 degrees below that number. If there is no station on the air on that particular wave length and nothing is heard, set dials No. 2 and No. 3 about two degrees higher and again rotate dial No. 1 above and below that number. If nothing is yet heard, continue in the same manner until the whole scale has been covered. At some point a station will be heard, perhaps only faintly, if on the air.

As soon as a station is heard, readjust each of the three dials, starting with dial No. 3, then No. 2, and lastly No. 1 until the point is found on each where the volume is greatest.

As the volume will now probably be too great on a nearby

This is the Quadraformer set as we built it at Station 3XP. You will note that we mounted two of the Quadraformers on the back of the panel so as to allow a wider separation of the apparatus on the baseboard. We used the new Karas audio-frequency transformers and the neat Apex dials, both of which are proving so satisfactory among radio fans. The mounting of the coils in this way gives just comfortable room for the three Cardwell condensers, the Pacent rheostats and the Carter jacks and switches.

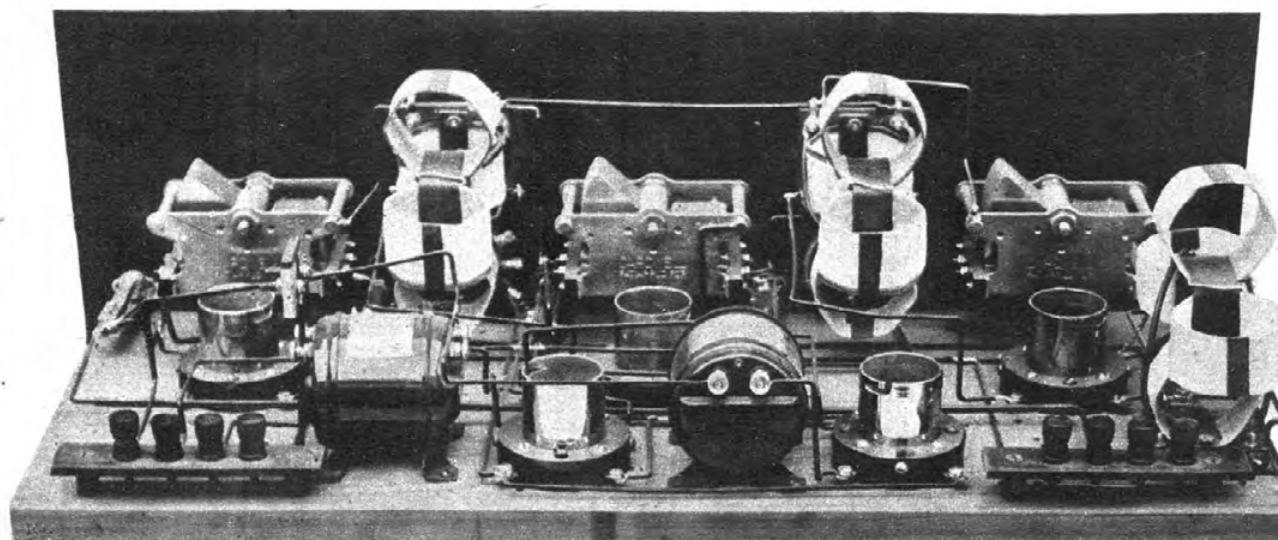

station, adjust the volume control knob to the most pleasing intensity.

Now observe your dial readings on all three dials. It will probably be found that they are not all quite alike. In any event, if you properly fastened the dials onto their shafts (with the

and a lot of fun but not worth the undeniable burden which a large expenditure of spot cash places upon the average man.

To be able to get a complete outfit for one hundred dollars or less and to be able, in addition, to make the

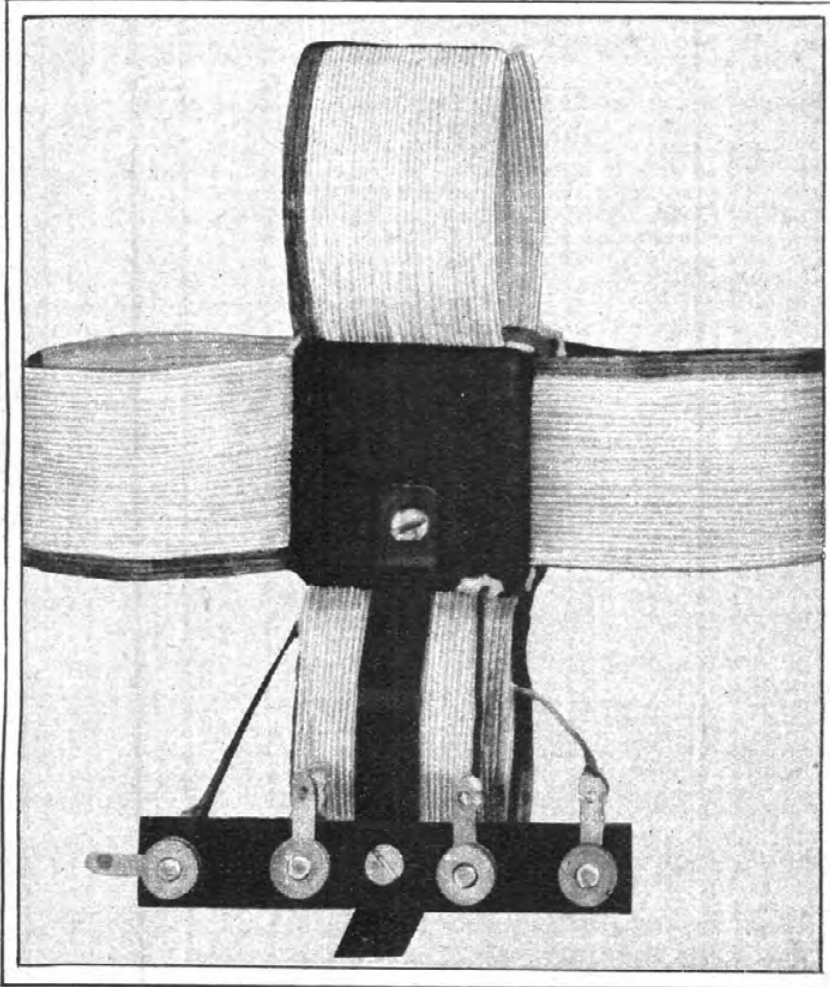

Fig. 1. The commercial Quadraformer

dial reading exactly 100 when the condenser plates are all in) they will read very nearly alike. Write down the dial readings for the stations as received, and that station can always be again tuned in by setting the dials to the same numbers. No. 1 dial, which tunes the antenna circuit, is the only one that may vary slightly from the recorded setting when using a different antenna.

Editorially Speaking

(Continued From Page 3)

profit. This dumping of receiving sets by the department stores has been a painful and a costly thing to all of us who are in the radio business. Pick up any radio magazine today and compare the small amount of advertising which we are carrying with the advertising which we carried last December and January. If you have ever been in the publishing business, you will wonder how we are able to pay salaries. Maybe we aren't. Still we are going ahead just as the radio manufacturers are going ahead, confident that this is only a temporary liquidation and that it will turn out to be a good thing for radio permanently.

The benefit to radio lies in the fact that this whole department store dumping has placed excellent receiving sets at the disposal of people who are not sufficiently interested in radio to spend a large sum of spot cash upon it. These people want good entertainment in their homes; they know what radio will do and they are probably quite familiar with it, having listened to the sets of friends. They are not, however, technically inclined nor are they fans in the sense that you and I are fans. They regard radio merely as entertainment or as a hobby which is interesting

necessary arrangements for time payment has at last brought them to the buying point and they are entering the ranks of the listener-in by the hundreds of thousands.

The more such people we have in radio, the better it is going to be for all of us. They will probably not be the buyers who will immediately purchase each new type as it comes out each season at its original value, but they will always be in the market for a good second-hand set or to absorb the overproduction which seems to be inevitable in the radio business as it is conducted at the present time. They will, in other words, give all standard receiving sets a resale value, and so the man who is sufficiently interested to buy a new type set each season will now spend more money because he will not have to junk the set which he already has in order to get a new one, but will be able to sell it at a fairly decent price and so reduce his actual yearly expenditures while at the same time being a ready market to the manufacturer for the new models each season.

I think we have an excellent illustration of this tendency in the automobile trade. The resale value of a Ford car is one of the best selling points which the new models have. Any one buying a new Ford knows that when he wants to change he can get a decent price for his flivver if it is in half way good condition. If he could not resell it, he would probably not be ready to get a new car for a number of years or until his present outfit was absolutely unsatisfactory. As it is, with a decent resale price always available, he looks over every new announcement of the Ford Company and of all automobile companies and he is constantly buying because he can constantly resell.

I doubt very much if the nook-up

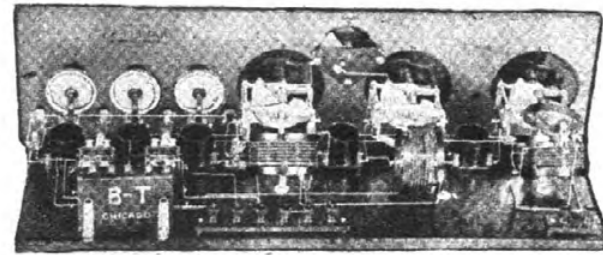

"The Last Word in Selectivity—"

—Chicago Evening Post.

"Owners of the 'NAMELESS,' properly built, possess the last word in selectivity on an outside antenna," says the well-known radio authority, Freund, in the Chicago Evening Post of April 2, 1925.

"New York Swept by 'Nameless' "

—New York Telegram-Mail.

"Out of the Windy City has blown the wonder circuit of 1925. The entire Middle West has been shaken by the veritable tornado of popularity attending its introduction, and now New York radio opinion is beginning to shake under the gale of approval that has greeted this circuit. This veritable wizard of the ether is the Bremer-Tully 'NAMELESS.'"

The "NAMELESS" circuit with condensers and coils of B-T quality has set a new standard in Radio Efficiency.

Ask your dealer for a circular or write direct.

BREMER-TULLY MFG. CO.

532 S. Canal St.

Chicago, Ill.

New Model

"C"

**For Better Radio
Hammarlund
PRECISION
CONDENSER**

(Copyright March 17, 1925)

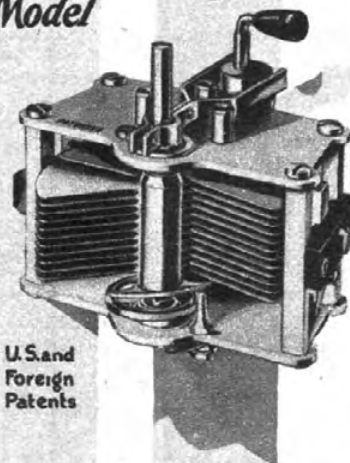

U.S. and Foreign Patents

When you find Hammarlund Condensers in the receiver you buy, it indicates that the manufacturer built for quality, not price, and that uppermost in his mind was your complete satisfaction.

Hammarlund Condensers are not expensive, but it is often expensive not to use them.

All models: plain and vernier. Sold by the better radio dealers; used in the better radio receivers.

Write for Interesting Folder

HAMMARLUND MFG. CO.
424-438 W. 33rd St., New York



EARN
\$50 to \$200
A WEEK!

Become a Radio Expert

This is the time to get into Radio—the new, fast-growing, uncrowded profession. Stop working long hours for small pay at work that is drudgery. Men from all walks of life are taking advantage of the big opportunities now open in this wonderful new industry. Salaries of \$100 a week—and more—not at all uncommon!

Learn at Home

You can train for this "big-money" field right in your own home—in spare time. You need know nothing about Radio or even electricity—the National Radio Institute—the largest and oldest home study Radio school in the world, established 1914—can quickly make you an expert through a marvelous method of practical instruction—which includes all material for building the latest Radio apparatus.

Big Demand Now

Almost every day we get urgent calls for our graduates. The big jobs hunt YOU when you are a Radio Expert. Radio offers you more money than you ever dreamed possible—a chance to travel or to take any one of the many Radio positions all around you at home. And Radio offers you a glorious future!

Send for FREE Book

Write today for free book, "Rich Rewards in Radio." Tells all about this great new money-making field—and describes our amazing practical method which gets you the BIGGER PAYING jobs in Radio.

No obligation
mail postcard NOW
National Radio
Institute
Dept. 54HB,
Washington, D. C.



The National Radio Institute,
Dept. 54-HB, Washington, D. C.

I am interested in Radio as a profession. Send me, free and without obligation, your interesting book, "Rich Rewards in Radio," all information about your spare time, home-study plan and free employment service. Also the details of your Special Offer.

Name..... Age.....
Street.....
City..... State.....

fraternity is going to increase in the future. As I said in an editorial some time ago, I believe that it is merely going to move out into the country farther and farther. I believe that wherever the hook-up craze does strike, it will do just what it has done in the past—it will thrive for a certain period and then turn over into the complete set market as the hook-up craze moves on farther out into the wilderness. This will keep the hook-up market fairly constant although always shifting in location, but will always increase and steadily enlarge the market for the manufactured set and the high-class accessory. The hook-up, in other words, is the missionary going out into the wilderness to preach the gospel so as to make the wilderness a fitting place for the established church.

Next season will, I think, bring us to a much clearer understanding of the tremendous problems of broadcasting wave length assignments, and I look to see a fairly satisfactory settlement by the end of the coming winter. I cannot too strongly emphasize here to the new readers that they must not continue to blame Secretary Hoover for the present chaos as so many of them do in their letters to me. Secretary Hoover has absolutely no authority to do any more than he is doing; in fact, he has not really the legal authority to do as much. It is simply that he realizes that a high government official has a certain moral authority in insisting upon amicable agreements among conflicting interests, and this is what the Secretary is using when he calls his conferences on radio. We go down to Washington, we thresh out our difficulties, we come to some sort of compromise and everybody agrees to stand by the agreement reached there. There is no law about it; it is simply that everybody realizes that to refuse to abide by the opinion of the conference would arouse public resentment, which would be a costly business liability.

That is what Secretary Hoover has been doing and is continuing to do. If, as it is reported in the newspapers, he issues a call for another conference in September, I think that this will go a long way to making reception better next season than it was last season. September is the time for holding a conference of that kind. We have all been through a strenuous six months during the past winter and this experience has taught us a lot of things about the present problems in broadcast reception. We will have the summer to think the problems over and to devise plans for solving them, and, if a conference can be called in September and if it can reach further agreements for simplifying the broadcasting situation, we can start the next season much nearer to a satisfactory arrangement than we have ever been before.

It seems to be definitely established now that it is impossible to separate stations by more than the present ten kilocycles. This means two things—it means that receiving sets must of necessity be made more selective, and it also means that there must be some method of constant checking up on the wave lengths of all stations that are broadcasting and some method by which every station may be forced to readjust to its assigned wave length the moment it strays away from it. When you get a heterodyne whistle in your receiving set, you must not blame the ten-kilocycle separation. Two stations which are really ten kilocycles apart will not cause a heterodyne whistle.

Unfortunately, it is virtually impossible at present for the average broadcasting station to stay definitely upon its wave length unless there is some adequately equipped laboratory at hand to check up on the wave

length the moment the station puts its carrier wave in the air. I believe that this problem will also be solved and, with the stations accurately upon their assigned frequency, the heterodyne whistle should disappear on all except the wave lengths below about 280 meters. Down there, the situation is hopeless and will have to remain hopeless until some one has the authority to refuse to grant more broadcasting licenses and to weed out some of the stations which already have licenses. Unfortunately at the present time no one has such authority and this authority cannot be granted except by act of Congress. Consequently, do not expect satisfactory reception of the lower wave lengths in the broadcasting bands. It cannot be done at the present time.

This necessity for crowding stations as closely together as this is, as I have said, going to give rise to a demand for increased selectivity in receiving sets of next season. I look for a revival of interest in the superheterodyne. This circuit has already been discussed a number of times in these columns and I have in the past said some unfavorable things about it. The old type superheterodyne apparatus was so constructed that quality was entirely suppressed for the sake of distance and selectivity and the resulting signals were not the kind that a musically trained ear could tolerate.

There is no question that the superheterodyne has many advantages over the other circuits. With the best of the standard kits recently developed and now on the market, it is going to be a serious contender next season, and the added selectivity of the directional loop aerial is going to be one of its strongest selling points. I have been using a Cotton superheterodyne in my own home lately with an Amplion phonograph attachment on my Victrola, and if radio never advances one inch beyond the results which I am getting I shall be perfectly satisfied with radio as it is.

I feel now at the end of this present radio season that we have at last got started in radio. I feel that previous seasons were a blind and uncertain groping about to find our footing, but I believe that we are now getting our feet firmly on the ground and that we are going to go ahead and make this wonderful hobby of ours the greatest force in human enlightenment and unity that science has yet offered to mankind.

Let's Cut Out Those Whistles

(Continued From Page 14)

two of a very powerful station. This question of living next door to powerful broadcasters is another subject on which the National Bureau of Standards has been working vigorously in the public interest. Foreseeing the troubles that now are all too keenly realized the Bureau some time ago took a stand against placing big stations inside big cities. At that time, such a stand was decidedly unpopular with the industry as a whole, but the wisdom of the stand is now unquestionably demonstrated and many of the most progressive stations, realizing the inevitable need for moving out into the country with their transmitting equipment already have built or are building new transmitting stations in suburban or country districts. This removal to the country reduces to a very small number the receiving sets which are so strongly affected by a single station that there is no hope for them of getting distant reception while the nearby station is operating.

Fortunately the bureau experts in radio also are "fans" and they have combined with their pleasure in receiving high-class programs a study

of just what limits will probably have to be observed to avoid serious blanketing effects. And, I am glad to say, they are all optimists on this subject. They point out that under the radio conference recommendations no two stations in a given radio zone are supposed to be assigned frequencies closer than 50 kilocycles to each other and a minimum separation of 20 kilocycles between stations in adjacent zones should be observed. If this is done, one who lives two miles or more from all ordinary Class B stations can, with a first-class wave trap or with a superheterodyne, tune out such stations and get any other station he may wish that is within his listening range. Of course, the reception may not in every case be perfect, but with the improvements that now are definitely in sight we can expect it to become practically so in the very near future.

However, despite this encouraging advice, if the presence of a big broadcasting station using 1500 or 2000 watts within five miles is expected, the writer is still a bit of a skeptic as to the possibilities of getting other stations less than 50 kilocycles separated from it. Hence there is little likelihood that the demand for a "silent night" once a week is going to disappear altogether.

By the time this discussion comes to the readers of *Radio in the Home*, there will be still another sort of interference very much in evidence again. This will be caused by "static," that mysterious and little-understood summer phenomenon of atmospheric electricity. Thus far the most commonly proposed cure for static troubles seems to be increased signal strength. But that cure is not one which can be universally applied, for only the big stations can, or should, use largely increased transmitting power.

For the present, however, the only alternative by which one may minimize the static interference at low cost is the use of the indoor loop antenna. And most of us are still inclined to fish for distance and hence are not altogether willing to accept a loop antenna as our only signal source.

The question of increasing station power is one that always causes differences of opinion. But the Bureau of Standards experts have an interesting suggestion on this point, too. They object to rating stations on the basis of the power input at the tubes. This is really no accurate measure of the station's signal strength and, after all, the usefulness, and hence the rating, of a station should depend upon its ability to produce signals or electric fields of a given strength at a given distance. The time may well come, therefore, when Uncle Sam's experts will rate the stations according to this characteristic. Thus our favorite broadcaster might be rated at "200 microvolts per meter at five miles," instead of at "500 watts," as now. Until some such thing is done we will have no real gauge of the effective power of a station, for the current consumption is of no more interest to the listener than the number of lead pencils used.

Of course, one must not expect that signal strength will be just the same in all directions from a station. It is well established that big buildings cast "radio shadows" which are even longer than the shadows which they cast just before sunset. A radio contour map made by one of the big New York stations showed the Woolworth Building casting a great shadow off across Long Island and Southern Connecticut. This apparently resulted from the absorption of the signal strength by this great structure, so that very little of the radiation could travel effectively from the transmitting antenna in this direction.

Counterflex Circuits for Experimenters

(Continued From Page 12)

of the circuit are arranged so that exactly half of this capacity is required to balance the system accurately, it would then be necessary to increase the counteracting capacity to its maximum value, or decrease it to its minimum value, to produce self-oscillation. It may appear, incidentally, that this would be the ideal way to arrange the values of the circuit, but this is not the case. It is better to arrange the values so that nearly all the counteracting capacity is required to balance the system accurately. Then self-oscillation can be produced only by decreasing the counteracting capacity.

When a Counterflex circuit is arranged in this way self-oscillation usually takes place when less than 10 or 20 per cent of the counteracting capacity is used. Above this approximate value the tube will not oscillate. It will be readily seen that the counteracting capacity of the Counterflex circuit is, in fact, a very useful and easily adjusted audibility control.

And now we will consider some practical Counterflex circuits. In Fig. 3, I show the standard three-tube Counterflex circuit which I have already explained in detail, and for which building instructions have been given. The circuit of Fig. 3, however, is slightly different from the original three-tube circuit. A different method is used for coupling the antenna to the tuned grid circuit of the reflex tube.

In the original Counterflex circuit the antenna was connected to a coil which was inductively coupled to the grid coil L1, the opposite end of the antenna coil being connected to ground. This arrangement was not found to be quite selective enough when the receiver was located near powerful broadcasting stations. Last month, therefore, I suggested another method of coupling the antenna to the grid circuit. I suggested that a small variable capacity (about the same value as the counteracting capacity) be used for this purpose, connecting this coupling condenser directly between the antenna and the grid of the reflex tube. This variable coupling condenser proved to be a very excellent selectivity control.

Since writing last month's article, however, I have experimented further with this idea and I find in the vast majority of cases a variable coupling is not necessary. A fixed value of capacity coupling can be used, provided the coupling is loose enough to give selectivity, even under difficult conditions. If a fixed coupling condenser were connected directly between the antenna and the grid, however, it would have to be a very low value, much lower than any of the fixed condensers readily obtainable on the market. Even if such low capacity fixed condensers were obtainable they would probably not be uniform, and slight differences in capacity would have a large effect upon selectivity.

The same loose coupling effect, however, can be obtained with a comparatively large fixed condenser if it is connected between the antenna and a tap on the grid inductance L1, instead of directly to the grid. Slight variations in the value of the coupling condenser do not then have much effect upon selectivity. I find that very excellent selectivity can be obtained by using the values indicated in Fig. 3, and, more clearly, in Fig. 4.

If you have a standard three-tube Counterflex receiver you can very easily make the changes necessary to improve the selectivity of your set. Just remove the primary winding of

Counterformer T1 and tap the center turn of the secondary coil. Then connect a .0001 mfd. fixed condenser between this tap and the antenna, as shown in Fig. 4. If, by any chance, your set then develops a 60-cycle hum or picks up other interference of this nature by induction, you can remedy this condition by connecting an inductance directly between the antenna and ground.

The value of this inductance is not critical. About sixty turns of No. 22 on a three-inch tube will serve, but this coil must be turned at right angles to the grid coil L1 and should be as far away from it as possible.

It will be realized that this method of antenna coupling not only affords excellent selectivity, without complicating the operation of the receiver, but also obviates the necessity of using a transformer to couple the antenna and grid circuits. A single coil, with a center tap, is all that is needed.

When I was working with this, the idea occurred to me that the same thing could be done with the transformer coupling the plate circuit to the second tuned circuit. If so, the construction of the receiver would become very simple indeed, even if the operation was not improved. I decided to try out this idea first with a receiver using a crystal detector instead of a vacuum tube. The idea worked out very satisfactorily. I tried various arrangements and finally decided on the circuit of Fig. 5 as the best. As you can see, it is very simple. Instead of using ordinary transformer coupling between the plate circuit and the L2-C2 circuit, direct magnetic coupling is used, a portion of the coil L2 being common to both circuits. In Fig. 5 the plate circuit is shown with heavy lines so that you can trace it easily.

While I have not made any scientific comparison between this circuit and the original circuit with ordinary transformer coupling, the audibility seems to be every bit as good, if not better. In any case the change is an improvement as the construction of the transformers is greatly simplified. With the original circuit it was necessary to have two different types of transformers (T1 and T2). Although there was nothing very complicated about these transformers a great many home-made sets were inefficient because the coils were not wound right or were incorrectly connected in the circuit. With the circuit of Fig. 5 I hardly think it is possible to make a mistake. In the first place, L1 and L2 are exactly alike. Each has the same number of turns and each is tapped in the center. The connections are so simple that it would be almost impossible to make a mistake.

The simplicity of this circuit, however, is not its only advantage. There is another very important feature. When the correct constants are used the two tuning dials read alike when the circuit is tuned to any given frequency. That is to say, if a low-wave station tunes at 20 on the first tuning dial, it also tunes at 20 on the second dial. Similarly, if a long-wave station tunes at 85 on the first dial it tunes at 85 on the second dial.

Furthermore, the dials read alike, no matter what type or length of antenna (with reasonable limits) is used with the circuit. For example, the dials read alike with an eighty-foot antenna and they also read alike with a 125-foot antenna. The very fact that the dials read alike is alone an important improvement. It is usually very difficult to accomplish this with a reflex circuit. It is accomplished in this case because the tuning constants in the antenna-grid circuits are practically duplicated in the plate detector circuits. Ordinary variations in antenna capacity do not affect this arrangement because of

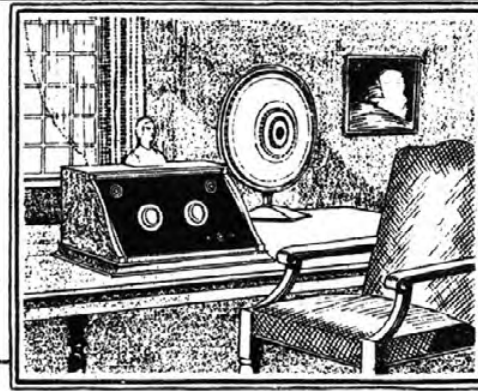

FORMICA IS THE MARK OF QUALITY IN RADIO

Formica panels, tubing and sub bases are the marks of quality in a radio set. You can be sure that the set which has them has been built for life time service—and that enduring good performance has not been sacrificed to the saving of a few cents here and there.

It is more necessary than ever this year to judge a radio set by the material it contains. Price competition last year brought in the type of apparatus that would perform beautifully for a week or two and then quit. And price competition is still with us.

Formica is used by nearly all the great makers of high quality apparatus. They swear by it as they always have. Be sure you have it in the set you buy.

THE FORMICA INSULATION CO.
4654 Spring Grove Ave., Cincinnati, Ohio

Sales Offices:

50 Church Street.....New York, N. Y.
9 South Clinton St.....Chicago, Ill.
516 Caxton Bldg.....Cleveland, Ohio
1142 Granite Bldg.....Rochester, N. Y.
422 First Avenue.....Pittsburgh, Pa.
6 Beacon Street.....Boston, Mass.
55 Calle Obispo.....Habana, Cuba

1026 Second Avenue.....Minneapolis, Minn.
725 Bulletin Bldg.....Philadelphia, Pa.
708 Title Building.....Baltimore, Md.
585 Mission Street.....San Francisco, Calif.
419 Ohio Building.....Toledo, Ohio
309 Plymouth Bldg.....New Haven, Conn.
Whitney Central Bldg.....New Orleans, La.

- Write for Booklet, "What Formica Is"
- 1 Formica is used by 125 leading makers—and has for years been used by more makers than all other materials.
 - 2 Formica will last forever.
 - 3 Formica, in appearance, is the finest of all panel materials and always remains so.
 - 4 Formica's electrical qualities of every kind far exceed any possible requirements.

- 5 Formica has high mechanical strength and will not break in use.
- 6 Formica will not sag from heat or cold flow under pressure. It retains its dimensions. Everything you fasten to it stays tight and precisely where you put it.
- 7 Formica panels are sold in neat craft paper envelopes which assure you that you are getting the genuine.
- 8 Formica is one of the most widely approved materials in radio.

FORMICA

Made from Anhydrous Bakelite Resins
SHEETS TUBES RODS

Hear the Formica Orchestra every Tuesday evening from 8 to 10. Central Standard Time, over WLW.

"You've got a wonderful set with all the power and none of the grief of the Supers"

SO writes Henry M. Neely, Editor of RADIO-IN-THE-HOME. He adds:

"This afternoon we hooked up the QUADRAFORMER KIT you sent us. It took about half an hour. This evening we traveled west with it, and at this minute a mixed quartette is singing a negro melody at KFI (Los Angeles)—2357 miles away from us. I am thirty feet from the loud speaker and hear it clearly. These coils certainly know where they come from!"

The GEARHART - SCHLUETER SUPER-FIVE is a trouble-proof set, far more sensitive and far more selective, of greater volume and more natural tone than any set that you have ever heard.

All so-called "neutralizing" devices are done away with. They are not needed. Internal set noises are eliminated, instead of being imperfectly suppressed. The QUADRAFORMER System will reward you with a remarkable difference in real music—

rich sweet tones, and great volume (without distortion) when desired.

Write today for the QUADRAFORMER BOOK. It will start you on the way toward a new radio experience.

Profusely illustrated with photographs and drawings, it takes you step-by-step through the making of a 5-tube GEARHART-SCHLUETER receiver. The method of description simply takes all the difficulties right out of the set construction.

Don't doubt—know for yourself what the QUADRAFORMER System is. Just write and ask for the QUADRAFORMER BOOK, enclose 25c to cover cost of handling and mailing and you'll have it by return mail. But don't delay—the number of copies available for this offer is limited.

Gearhart-Schlueter
Radio Corp.

P. O. Box 212, Fresno, California

This Amazing New-Type Coil is Revolutionizing Radio Set Building

MODERN electrical science has discovered a new principle in radio-frequency amplification—a new improved transformer that gives the most amazing results.

It is known as the Erla Circloid. Simply clip the coupon below—and let us send you the complete technical story.

Three vital improvements

The story of Circloid advantages is a fascinating study—even for those who are not interested in the technical side of radio.

As practically everybody knows, in the ordinary radio set, not only the antenna but the radio-frequency coils themselves act as pick-up devices of broadcasting signal. This is one of the chief causes of what most radio fans call "broad tuning."

With Erla Circloids, independent pick-up of signals by the coils is completely done away with. Selectivity of the receiver is always at maximum. Sharp tuning and less interference are the direct result.

Static disturbance has been reduced to the very minimum. For everybody knows that static has no particular wave length. It invades them all. And because the Circloids have no pick-up qualities, only such static as happens to be present on the exact wave length to which the receiver is tuned can come through. Thus here at last is a radio set that offers new delights in summer-time radio. No other receiver

Three Great Advantages

1. The absence of an external field eliminates the effect of the coil upon nearby coils or adjacent wiring circuits.
2. The Circloid has no pick-up quality and is rendered immune from outside electrical influence.
3. Its efficiency is higher than any other type of coil and losses are unbelievably low.

The New Erla Balloon Circloid Radio Frequency Transformer and Coupler

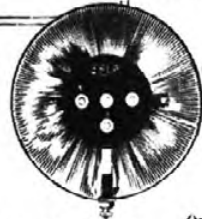

\$4.00 Each Patent Pending

can provide such perfect freedom from annoying interference.

Another Circloid improvement is greater stability—smoothness of operation and ease of control.

The tendency of conventional receivers to squeal and howl uncontrollably is due to excessive feedback between coils and wiring circuits.

With Circloids feedback of energy is eliminated between coils and confined solely to the wiring circuits where it is subject to complete control. Thus perfect stability is obtained. Oscillation that is sudden and violent in the average receiver, making it necessary to start tuning all over again, is now controllable. Just the slight turn of one control and it is completely controlled.

But the most important of all Circloid improvements is its effect upon tone quality. Any radio engineer will tell you that excessive "feedback" is the greatest cause of distortion or blurring.

And Circloids, because they have no external field, eliminate stray feedback effects and do away completely with this principal source of tonal distortion.

Only with the Circloid principle can supreme musical clarity and fidelity of reproduction be obtained. No other radio set can offer you these exclusive advantages. No other set can offer these supreme achievements.

4 ways to buy the Circloid

Erla Circloid Transformers are offered for sale, \$4.00 each—in kits of three, \$12.00—in kits of three with Erla Condensers, \$21.50—and in Factory-Built Kits, \$49.50. They may be obtained direct from your nearest dealer. Or write direct for detailed information.

the loose coupling between the antenna and the L2-C2 circuit.

The selectivity of this circuit is unusually good. The arrangement previously described, and illustrated in Fig. 4, is used. In fact, from every point of view I believe this circuit is exceptionally efficient. I am almost willing to wager there is not another one-tube circuit which possesses all the advantages of this one and I honestly believe it is by far the most efficient one-tube circuit in existence. I shall briefly summarize its advantages:

High Audibility: The audibility of this one-tube circuit is at least equal to that of an ordinary two-tube set with regenerative detector and one stage of audio-frequency amplification.

High Selectivity: The selectivity is remarkably good, especially in view of the fact that the circuit has only

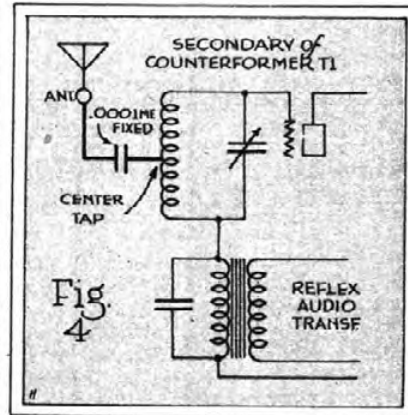

two tuning controls and has very high audibility. Even if a set using this circuit is located within a quarter of a mile of a powerful broadcasting station it is possible to tune in other stations 50 kilocycles away without interference. This, of course, is an extreme case. If the set is four or five miles from the local station it will be able to tune in stations 20 kilocycles or less away without interference. When receiving slightly more distant stations, of course, the set will separate stations 10 kilocycles apart without any trouble.

In other words, this circuit in common with the circuit of Fig. 3, is suitable for use in districts like New York where selectivity is of the utmost importance.

Simplicity of Operation: There are just two tuning controls and, as I said before, the dials of these two controls always read alike when the set is tuned to any given frequency. If desired, the audibility can be controlled with the counteracting capacity or this capacity can be left permanently in a position which prevents the tube from oscillating.

Ease of Construction: The parts used in this circuit are all very simple. The coils L1 and L2 are not critical values. They have only to possess sufficient inductance to enable the tuning condensers to cover the broadcast range of frequencies. With two .00025 mfd. condensers, 60 turns of No. 22 on a three-inch tube will be about right, in each case. Each coil is tapped in the center. I am using low-loss self-supported coils and find them very satisfactory.

Low Cost: This circuit does not cost any more to build than a two-tube set with regenerative detector and one stage of audio-frequency amplification, and yet it uses only one tube and possesses all the other advantages mentioned above.

As you can see, I feel rather enthusiastic about the operation of this circuit, but if you built a three-tube Counterflex with the original circuit, as in Fig. 3, please do not start tearing it down to use the circuit of

Build it Yourself!
New 3-Tube,
Harkness Type
Counterflex Circuit
Complete
Parts
Special
at **\$17.50**

Including Triple-Socket Sub-Panel and Drilled Panel, With Shamrock Transformers & Parts As Described in Radio in the Home for March.

One of the big specials of the year. Has taken country by storm. Gaining popularity every day. 5-tube set efficiency with 3-tube set economy. Loud speaker reception up to 1500 miles. So simple child can operate it. Dials always log.

Our radio engineers have specialized on this set for years. We recommend it, and have sold it in every part of the country to radio fans who are enthusiastic about it.

Recommended by Henry M. Neely in one of his feature articles in this issue

The M. & H. Radio Engineering Service Will Supply Parts or the Complete Set of Any Hook-up Ever Published in Any Issue of This Magazine at No Extra Charge This Service Is Recommended by HENRY M. NEELY

Another M. & H. Special Complete Parts New Quadraformer 6-Tube Circuit... \$47.25

Including Base & Panel As Described in Radio in the Home Last Month Regular Price, \$60.58

A tried and proven circuit with a new coil that kills self-oscillations, the drawback of every radio-frequency circuit. New Jersey to California on loud-speaker several times in week is this set's record.

Still Another Special COMPLETE PARTS BROWNING-DRAKE 3-Tube Set... \$34.75 Described in April "Radio in the Home" Regular value, \$46.40

Only One Kind of Quality here—the best. Radio Sets that give satisfaction demand quality parts. We use no other. Our reputation built up by 29 years' faithful service, is back of each sale.

M&H
SPORTING GOODS CO.
 512 MARKET ST. PHILA. PA.

ERLA *CIRCLOID

Radio Frequency Transformer

*Trade Mark Registered

Electrical Research Laboratories, Inc., 2508 Cottage Grove Ave., Chicago, Ill.

Gentlemen: Please send me detailed information about the new Erla Balloon Circloid Transformer.

Name

Address



READY-WIRED UNITS
 for all of the favorite circuits.
 Detector unit Detector and one step
 Detector and two steps
 Two-step amplifier
 Five tubes for any hook-up
KARDON PRODUCTS CO.
 451 Greenwich St., New York City
 Philadelphia Office, 608 Chestnut St.

Get Clearer Reception This Summer!
 Charge Your Batteries More Frequently and Be Troubled Less With Static

Porch dancing, baseball scores, concerts and folk songs, of long ago—summer radio's contribution to your evening entertainment—may be made more enjoyable by NOT giving "static" the chance to intrude. Keep your batteries fully charged the Sterling way and avoid most of that hot-weather static. It's so easy—just connect up and turn the switch. No extra connections, no lamps or liquids to bother with.

Model 15 (for A & B Batteries) 50 or 60 cycle \$22.50 25 cycle 25.00
 Model 17 (for A & Auto Batteries only) 50 or 60 cycle \$15.50 25 cycle 21.00

THE STERLING MFG. CO.
 Dept. K., 2891-53 Prospect Ave., Cleveland, O.

Sterling
 RECTIFIER
 CHARGES "A" AND "B" BATTERIES FROM A SINGLE UNIT

Fig. 5; or if you contemplated building a three-tube Counterflex, go right ahead. The Fig. 3 circuit is by no means obsolete.

If any of the modifications given here, or in later articles for the benefit of experimenters, appeal to you, you will find that you can very easily change your set to use these modifications. Next month I will show you how to use the system of Fig. 5 with the three-tube circuit of Fig. 3.

Fig. 6 is the same circuit as Fig. 5. It is included to show experimenters the value of the fixed condensers, the arrangement of the binding posts and telephonic jack and the connections to the audio-frequency transformer.

Fig. 7 shows the same circuit with an extra stage of audio-frequency amplification. This, of course, is the most practical circuit to use. The audibility is increased so that a loud-speaker can be used and good volume obtained.

I shall be very glad to receive reports from readers who experiment with these circuits.

(To be continued next month)

Those Short Waves

(Continued From Page 7)

shorter waves, use multiple reception to obtain better quality, and thus be able to rebroadcast the signal on the regular broadcasting waves. This is now done quite often, in particular by the Westinghouse Company, through their Station KDKA, at Pittsburgh.

Another point in question concerning the use of short-wave transmission is the common belief that the short waves travel as well by day as by night.

Very unfortunately, indeed, this is not so. It has been found that waves in the range of 20 to 30 meters reach out much better by day than by night; exactly opposite to those in the usual broadcast range of from 225 to 600 meters. Again waves of from 30 to 50 or 60 meters are apt to prefer the time from noon to midnight for long distances. There does not seem to be a happy medium that will travel as well by day as by night, although the field around 60 meters sometimes shows a little promise in this direction.

If we consider the field of waves shorter than 15 to 20 meters, we begin to enter the questionable; and for the waves of shorter than one meter in length it can only be said that here lies the Great Unknown with all its mysteries, thrills, and, if there be any, promises.

As to the question when broadcasting will be done on the short waves instead of those in use at present, let me remind you that this can probably only be done through congressional action or some other such action. This it is not likely to happen tomorrow afternoon. Again it is well to remember that there are now millions of dollars invested in broadcasting transmitters that would be useless for short-wave work. Also there is so much to be learned about the use of short waves that there are probably not enough engineering data available to assure success if the change were made to the short waves.

If any such change is made, it will come in the natural course of events after long continued work on the part of radio engineers. Like every other industry and art, radio progresses only in proportion to the time and energy devoted to it. On the other hand, the Westinghouse short-wave transmitter broadcasts regularly and simultaneously with the regular KDKA transmitter and has been heard in all parts of the world. Regular broadcasting on the short

waves is therefore happening at the present time, as you can see.

This brings us to the question often asked as to what can be heard in the short-wave range. It is, of course, not easy to answer this question because of the constantly changing conditions, due to the fact that all of the work that is being done at present is more or less of an experimental nature. One can be assured, however, that no matter where he lives the chances are that he will be able to hear KDKA. The author's station, 9XBG, has also been reported from practically the entire United States, although broadcasting from this station is necessarily of an infrequent nature. Stations in France and England have been heard in the Middle West, so that while there are but few stations broadcasting by means of short waves, their ability to cover greater distances often means the thrill of hearing a foreign station.

To return now for a moment to the question as to the greater distances possible with short-wave transmission. The amateur radio operator with his transmitter has been responsible for the importance that short waves are assuming in the field. Too, he is the one who has been able to point out by actual demonstration the enormous distances that it is possible to attain by their use.

This brings us to another reason for this article when I mention that so far we have been considering the use of short waves for radiophone work. The amateur has done but little phone work in the short-wave field; in fact, is not allowed to by his Government license, and there is a vast difference between the transmission of code and phone. Code, you understand, consists of nothing but dot and dash signals and, roughly speaking, has but one tone. Quality of tone does not count for much; it is the ability to get a signal through regardless, if necessary, of quality.

This rather more simple operation naturally aids the transmitter considerably. On the contrary, radiophone transmission requires the transmission of practically all of the notes or frequencies in the audible range, the full scale of the piano, various musical instruments, etc., and this, it can be seen, is a tremendously more difficult problem, because quality transmission becomes paramount in importance and it may be necessary to limit the distance of transmission for the sake of securing quality of reception.

So far in our discussion of the subject we have not been extremely kind to short-wave transmission, but we are also able to show very good reasons why their use may quite likely be universal at some future time.

As I have said, the amateur has shown the possibilities of distance transmission. He has done this so well that many times he has sent signals half around the world with only about as much power in his transmitter as is used to light one's reading lamp—surely a marvelous achievement and one that begins to make us wonder what is to come in short-wave power transmission.

We can also add one or two more advantages to the credit of short waves. One, for instance, the fact that it becomes possible to use extremely small antennae. The brass curtain rod, two or three feet long, above your window, would serve as a very excellent antenna for the transmission or reception of waves in the neighborhood of four or five meters long. Proportionately then, it should be possible to carry in our pockets, without folding, a perfectly good antenna for waves under one meter in length! Miniature transmitters, receivers and antennae, operating with small power expenditure,

Better Contact

An easy way to get distant stations clearly



Na-Ald DeLuxe Socket No. 400, 75c



Na-Ald Small Space Socket No. 401, 35c



Na-Ald Socket No. 411, 75c



Na-Ald Socket No. 499, 50c



Na-Ald Adapter No. 429, 75c

It's important at all times—but doubly important in summer, when static is apt to be troublesome—to have clean, perfect contact between tubes and sockets. If you don't, the almost unnoticeable films of corrosion act as barriers for the delicate currents; magnified, they cause annoying noises.

"It's the contact that counts"

Na-Ald Sockets remove those barriers. The exclusive side-scraping contacts (not just side pressure) of Na-Ald DeLuxe Sockets cut the corrosion from the sides of tube terminals. A turn or two of the tube—and the tube terminals are clean.

The Alden-processed Bakelite conserves all the current energy. Laboratory tests proved Na-Ald Sockets most efficient in low loss and low capacity.

Na-Ald Adapter No. 429 and Na-Ald Socket No. 499 are especially made for use with UV-199 and C-299, and No. 411 for WD-11 tubes, all of which are used with dry batteries. They are a big aid to the highest tube efficiency.

Use Na-Ald Sockets not only in the set you build, but also install them in the set you buy. At all dealers.

Mail coupon for free booklet, "What to Build," giving tested, selected circuits.

ALDEN MANUFACTURING COMPANY
Also makers of the famous Na-Ald Dials
Dept. J-7, Springfield, Mass.



Alden Manufacturing Co.,
Dept. J-7, Springfield, Mass.,
Send me free booklet, "What to Build"
Name
Address

"Last night we heard the sweetest voice"



Few boast of having heard a powerful voice. Radio has grown up. It is now something to listen to, not to marvel at. We are now in the cycle of TONE!

The other day a man said he was just realizing that he had a hundred dollars' worth of set and a dollar's worth of horn! His next move is to balance up his set with a good speaker.

The BRISTOL has all the volume you will ever want, but its fine point is TONE. It is good to listen to. The notes come in in tune. You receive a wealth of music from which the cream of tone has not been skimmed.

For \$20, \$25 or \$30 you can get a Bristol Speaker, and there are others for less. Ask your dealer to send one out to the house. And let us send you folder No. 3022-Q; it tells why the Bristol is the horn of tone.

BRISTOL AUDIOPHONE Loud Speaker

THE BRISTOL COMPANY, WATERBURY, CONN.



Fit for a King

Britain's greatest engineers, in designing receiving equipment for His Majesty, KING GEORGE V, chose Resistance Coupled Amplification. None other would do.

The DAVEN RESISTANCE COUPLED SUPER AMPLIFIER

will give to your favorite tuner that finesse in quality amplification desired for the Chambers of Buckingham Palace. With Resistance Coupling, overtones and undertones are amplified alike, therefore, distortionless. The most delicate shadings in musical composition, either with instruments or the voice, are reproduced with a faithfulness not obtainable with any other method of amplification. It costs less to install than other methods of amplification and adds greatly to the life of your "B" Batteries.



DAVEN RESISTANCE COUPLED KITS

These kits are put up in three or four stages and bring perfection of amplification to those who would rather build than buy a completely assembled Resistance Coupled Amplifier. Secure from your Dealer the "RESISTOR MANUAL," our complete handbook on Resistance Coupled Amplification. Price 25c. Postpaid 35c.

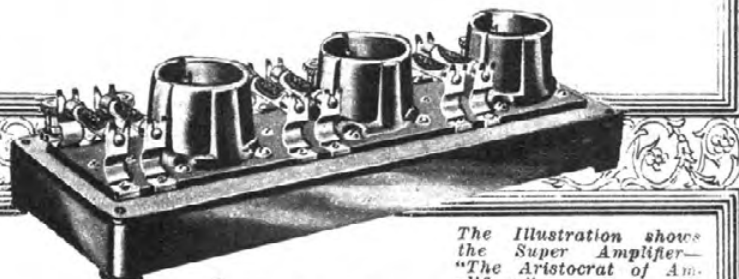

The Illustration shows the Super Amplifier—"The Aristocrat of Amplifiers."

The Sign of Merit

DAVEN RADIO CORPORATION
Resistor Specialist.
NEWARK, N. J.

yet able to communicate around the world, is something for us to dream about.

I have referred throughout this article to waves in terms of their length only because this has been the popular way of thinking of them. It is far better, though, to think of the waves in terms of their frequency rather than their length because it in a way means more.

For example, the length of the wave does not help us directly, so far as the much-discussed subject of selectivity is concerned. Selectivity is one of the factors that has determined for us how much radio we can use without destructive interference, and selectivity is primarily dependent upon the frequency of the wave.

To illustrate more clearly, perhaps, what is meant here, consider the wave lengths used in broadcasting—those from 200 to 600 meters long. A 200-meter wave has a frequency of 1,500,000 cycles, that is, it reverses its direction that many times each second. A 600-meter wave has a frequency of 500,000 cycles. Now, in general radio-phone work, with a receiver of the better type, two transmitting stations should be separated by a frequency difference of at least 10,000 cycles in order that they shall not interfere with each other. Between the 600-meter wave of 500,000 cycles and the 200-meter wave of 1,500,000 cycles there is a total difference of 1,000,000 cycles, which means that only 100 stations might operate within this band and be free from interference.

It will be seen from the above that the shorter the wave the greater its frequency. A wave one meter long has a frequency of 300,000,000 cycles per second and a wave of 5 meters length has a frequency of 60,000,000 cycles, a difference of 240,000,000 cycles. Dividing this by our necessary separation figures of 10,000 cycles we find that we could operate 24,000 stations in this band without interference. If broadcasting ever is done on the waves under 5 meters in length, it is conceivable that one might have to take about half a day off in order to find the local station unless more general use is made of wave meters.

H. M. N. I am sure would be glad to include in an early issue of *Radio in the Home* an article on how to build a short wave—or, for that matter, a universal range-receiver if my readers desire.

NOTE.—Sure I will. All that our readers have to do is to let us know that they want such an article and the necessary space will be allotted at once.
H. M. N.

Now Women Demand Their Share of Programs

(Continued From Page 17)

of soap have been put. Use boiling water for all of the dishes except the silverware.

Wash glassware first, then silver, then cups and saucers, plates and serving dishes. As I said before, it is easier to wash the pots and pans during the preparation of the meals.

Glassware will be brighter if not much soap is used, though a little makes it brighter. Using the dish mop, first wash the glasses inside and out, rinse them and place them upside down, slightly tipped, in the drain basket, and then dry them. The silverware may be cleaned satisfactorily and quickly with the mop, and this method keeps the hands out of the water.

Have you a drain basket? It is such a time saver and does away to a large extent with the insanitary dish towel. After washing the dishes, stack them in the racks and scald

CARTER

Radio Receptacle Jack for Wall Mounting

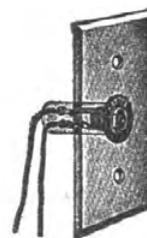

No. 302

\$1

Pat. 1-30-23

For use in homes, etc., for aerial and ground, battery and loud-speaker connection.

Fits all standard Radio plugs.

The jack can be mounted flush on the wall or baseboard, or in regular outlet box.

Extends 1 1/2" back of plate and is completely encased in shell.

The jack is provided with terminal screws—connections can be made without solder.

Any dealer can supply



In Canada—

Carter Radio Co., Ltd., Toronto

Carter Radio Co.
300 E. RACINE AVENUE
CHICAGO, ILL., U.S.A.

HARKNESS

Counterflex and Reflex Kits



MODEL "C"

The 3-TUBE CIRCUIT—Actually better than the average 5-tube.

List Price: United States ..\$39.50
Canada\$48.00

MODEL "B"

The ORIGINAL HARKNESS REFLEX Two Tubes and Crystal

List Price: United States ..\$35.00
Canada\$42.50

Both kits include all necessary parts and instructions. Reflex sets are the Best Summer Sellers.

Jobbers and Dealers—Write

KENNETH HARKNESS RADIO CORP.

727 Frelinghuysen Ave,
Newark, N. J.



Make Money Building This Set for Friends

Here is a 4-tube set with 5-tube volume and a wonderfully sweet tone. It is not reflexed, but employs the circuit (with improvements) which made the Greene Concert Selector such a favorite in the East.

The secret is the L+K Variable Clarifying Selector and the VT25 Variotransformer, so widely praised by radio authorities. The Selector is a patented aerial tuner that gives needle-point selectivity. The VT25 is a variable transformer, operating without a condenser, that gives the amplification of two ordinary fixed R. F. transformers. Both will improve any standard hook-up.

We'll supply all the parts and charts and free expert advice to build this excellent set. Get just one set working in your neighborhood and you'll soon be good and busy on very profitable work. Write for Free diagram spread and particulars.

Address

The Langbein-Kaufman Radio Company

511 Chapel St., Dept. R.,
New Haven, Conn.

An L+K Product
TUNERS **ELKAY** SETS, KITS

The **Low Loss**
Supercoils
Fully Adjustable for all Circuits
Three-Circuit Tuner **\$7.**
Is Shown Above

Basket weave windings—large wire—duplex insulated. Minimum of dielectric—each coil fully adjustable—180° tapper. Extreme volume—distance—selectivity. This Three-Circuit Tuner is endorsed by H. M. Neely—the Non-radiating Coil—The "Beginner's Best Set."

At all dealers or direct C. O. D. plus Parcel Post

Send \$1.00 for full-sized blue prints, for 18" panel and baseboard, lay-out and complete instructions for building the ideal three-tube set.

"Radio Broadcast's 'Knockout'"
Walter Van B. Roberts' Circuit—



Combining Radio Frequency, Regeneration and Reflex.

Supercoils are endorsed by Mr. Arthur H. Lynch, Editor "Radio Broadcast"

Per Set, 5 coils in 2 mountings, \$8

Tap Antenna Coils \$1.00 Extra

Jobbers and Dealers Write for Open Territories

Perfection Radio Mfg. Co.

Dept. R, 1520 Chestnut St., Philadelphia, U. S. A.

them with hot rinsing water. They look better and are certainly more sanitary when left to dry in this way than when dried with a towel. While they are drying, scald the dish mop and wash the sink. When you have finished, you will have completed what you once considered a distasteful kitchen task.

Quite recently there was brought into our laboratory a new non-electrical dishwasher which can be used on any faucet. This small water-power dishwasher includes a faucet attachment, a hose, a wire rack, two stiff brushes, a small mop and a rubber-edged pot scraper, with an arrangement for fitting the nozzle onto the galvanized iron handles of the brushes. The value of this device is that it is not necessary to put the hands in water at any time and the dishes are washed in hot soapy water followed by a clear rinse and dried in the drain basket.

One of the keenest joys that life can offer is the consciousness of having mastered an appointed task. We take pride and pleasure in work well done, and dislike that which we can do only in an awkward fashion. It follows that one who detests housekeeping and regards it as drudgery has not mastered her problem, and not until she has conquered the last puzzling detail can she know the deep joy of achievement.

All Records Smashed By Station WOAW

(Continued From Page 10)

labor before the jam was abated.

Added to this, there were employed by the Woodmen of the World the following staff: two announcers; two operators; fifteen hostesses; six telephone operators and two supervisors. The Postal Telegraph Cable Com-

ATLAS
RADIO TUBE
"BRINGS IN THE WORLD"
Made in All Standard Types

INSTRUMENT TESTED

Read the guarantee furnished with every Atlas Tube:

"This Atlas Tube has been individually instrument tested and is guaranteed to give entire satisfaction. If unsatisfactory for any reason whatever, it may be returned within a period of thirty days to the manufacturer or to the dealer from whom it was bought, provided the filament has not been burned out.

"Dealers are authorized by the manufacturer to make replacement or refund (in such cases) whichever may be desired by the customer.

Atlas Instrument-Tested Tubes are guaranteed to function efficiently in Reflex, Neurodyne, Superheterodyne, Radio Frequency or any of the circuits which require highest efficiency in tubes."

At best dealers or direct from us. **\$3.00** Mail orders promptly filled.

SPECIAL OFFER—At no extra charge, we will furnish selected, instrument-tested, matched tubes in sets as follows:

- Reflex Set—3 Tubes \$9.00
- Neurodyne Set—5 Tubes 15.00
- Superheterodyne Set—8 Tubes, 24.00

They will get the most out of your Radio Set.

DEALERS and JOBBERS—There is satisfaction as well as profit in handling ATLAS TUBES, the first tubes to be sold on merchandising principles affording full protection and satisfaction to your customers.

Write or wire for proposition.

THE RSK CO

309 Caxton Building, Cleveland, Ohio
609 Chamber of Com., Pittsburgh, Pa.



Lewis Grubtill, Western Union messenger No. 8, is one of the boys who helped deliver the thousands of messages to WOAW

pany maintained a staff of fifty-one persons in the Traffic and Delivery Department for the anniversary responses. This makes a total number of 435 persons composing the full staff which was necessary to direct the anniversary program in all the various departments.

Fourth, that fully three weeks were consumed from the time that the anniversary programs commenced to the time that the last prize was received by the farthest listener. This gives one an idea of the infinite detail of labor involved.

Fifth, that 22,123 winners had their

"pep up" your radio
for good summer reception

JEFFERSON
TUBE REJUVENATOR

keeps tubes like NEW!

YOU can't get good summer reception with weak tubes. All radio tubes weaken with use—especially in summer when burned at higher voltage. Keep your radio tubes efficient this summer with the Jefferson Tube Rejuvenator. Just attach to a convenient electric light socket—"bring back" each tube in 10 minutes!

For Home Use



Repeat once a month—note how it improves reception; DOUBLES and TRIBLES tube life, and saves batteries. It's wasteful to be without one; it's economy to own one. Takes large or small tubes—201-A, 301-A, UV-199, C-299. Fully guaranteed. Get yours now. At leading stores selling radio. If your dealer can't supply you, send \$7.50 to

JEFFERSON ELECTRIC MFG. CO.

501 So. Green St., Chicago, Ill.

Makers of Jefferson Radio, Bell Ringing and Toy Transformers; Jefferson Spark Coils for Automobile, Stationary and Marine Engines; Jefferson Oil Burner Ignition Coils and Transformers.

\$7.50
\$10 in Canada

Vigilance



Leadership



The most thorough accuracy and care in manufacturing and testing has enabled ALL-AMERICAN to hold continuously for a number of years the position of proven leadership in quantity of sales.

Such an achievement is the best possible proof of continued satisfaction given to users of ALL-AMERICAN transformers.

A new edition of the Radio Key Book, just off the press, illustrates an eight-tube set which is the sensation of the year. Send 10 cents for it now, coin or stamps.

ALL-AMERICAN RADIO CORP.

E. N. RAULAND, President

2666 Coyne St.,

Chicago

ALL-AMERICAN
Largest Selling Transformers in the World

AMPLIFIER AND DETECTOR
5 VOLT TUBE
DISTANCE MAKES NO DIFFERENCE
SEA GULL



"DISTANCE makes no Difference" is an accomplished fact to users of this latest development in amplifier and detector tubes.

Sea Gull Tubes prove superior in reproductive quality, clearness and tone differentiation.

Sea Gull Tubes are the result of expert skill in construction and constant supervision in maintaining the highest standards in operative test-outs.

These tubes cannot be overloaded under usual operating conditions found in superheterodyne, neutrodyne, tuned radio frequency, and reflex sets. A tube of remarkable performance.

We make a special high capacity rectifier tube for "B" battery eliminators, which is most remarkable.

Write us for details.

Send us your order today for Sea Gull Tubes.

\$3.00 per tube
 p. p. c. o. d.

ABERDEEN SPECIALTY CO., Inc.
 Mail Order Dept. 318
 1520 Chestnut St.
 Philadelphia

prizes announced from the radio station in the course of the week following the program. Of these prizes announced, more than 10,000 telegrams were read and the prizes announced in five hours of actual time by the two announcers. This, averaging five words for each telegram, including the sender's name, town and



Ina Deppe, Western Union dispatch messenger No. 1, who holds a record of having delivered more than 5000 telegraph responses to WOAW during the anniversary programs

prize, established a record of continuous radiocasting at the rate of 166 2-3 words a minute for five consecutive hours.

It does not really make much difference whether or not the various records established by Station WOAW are equaled or surpassed. Eventually, they will be, perhaps by WOAW itself. However, the significant thing is that WOAW has demonstrated to the world, not only its popularity but also that radio has attained proportions in the public interest absolutely unrealized prior to this epoch-making event. WOAW has, in its pioneering way, revealed that radio listeners of first-class stations can be numbered, not only by thousands, nor hundreds, but by millions, and of the millions of radio listeners throughout the United States, Canada, Mexico and South America, as well as the islands of the Pacific and Atlantic, WOAW has won a generous portion.

The Sound of the Silvertown Chimes

(Continued From Page 6)

was able to develop innumerable stars, such as Paul Henneberg, now conductor of the New York Police Band; Nicolo Lauchella, flutist of the Philharmonic and Metropolitan Orchestras, and Concertmaster Gussikoff, of the St. Louis Symphonic Orchestra.

Mr. Knecht's radio work began at WJZ on Sunday nights. When WEAJ decided this winter that it wanted to broadcast dinner music it chose that from the Rose Room at the Waldorf because that was the finest.

It is not surprising, therefore, to know that when the Goodrich Company wanted to organize the Silvertown Cord Orchestra it also asked Mr. Knecht to be its guiding spirit. You will find him balancing his

The Five Tube Set which startled the World!
FRESHMAN MASTERPIECE
The Greatest Value Ever Offered in A Radio Receiving Set
At all dealers!

LIKE A SENTINEL GUARDING YOUR RADIO
 The Lightning Season Is Approaching Protect Your Radio And Home NOW!
 with a **BRACH VACUUM ARRESTER**
 Used By Principal Railroads In U. S. And Canada For 19 Years To Protect Signal Systems



OLD MAN STATIC "KILLED" AT LAST

Statchoke Has Startled the Radio World—Insures Clear, Long Distance, Summer Reception.

The long promised invention which insures clear, long distance, "summer radio" without the agony of static, has just been announced. Radio experts and fans who have tested this new imported invention pronounce it marvelous. Awarded Certificate of Merit by Radio News of Canada.

In addition to reducing static to a minimum, the Statchoke increases the volume as well as clarity of distant reception, sharpens the selectivity of tuning in, eliminates that harshness of the tubes so noticeable on local loud speaker reception and acts as a safety lightning arrester.

The Statchoke somewhat resembles a small transformer, and by a system of coils it allows only the correct current value to enter the set, choking out other high current variations from the aerial, which is passed off through a secondary ground connection.

So confident are the American distributors that Statchoke will give you clear long distance, summer reception that they have set aside 1,000 units for initial distribution direct to the radio fans, at a special price of only \$2.50 each.

If interested write today to Radio Dept., Imperial Laboratories, 9605 Coca-Cola Bldg., Kansas City, Mo., and the Statchoke will be sent you by insured mail. Write today, as this is a special offer and may not appear again.



Obsolete

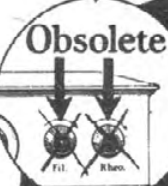

The HEART of the Circuit is AMPERITE
 The "Self-Adjusting" Rheostat

As the heart controls the flow of blood through the body, so AMPERITE, the self-adjusting rheostat, controls the flow of current through the tubes—automatically—never allowing too much to injure the tubes, and always permitting true tone qualities with proper volume. No hand rheostats. No guessing. Simplifies wiring. Improves operation. Used in over 50 leading sets and circuits. \$1.10 everywhere.

RADIALL COMPANY
 Dept. R.H.-8, 50 Franklin St., N. Y. City

Write for **FREE** Hook-ups

AMPERITE
 "means right amperes"



The Best Transformer Money Can Buy

You secure Marvelous Reception with these New KARAS HARMONIK Audio Frequency Amplifying Transformers.

Because they amplify with GREAT VOLUME the extremely low frequency tones that other transformers fail to amplify at all. They amplify EQUALLY all of the many vital harmonics and rich overtones that combine to form pleasing musical sounds.

There is no muffing of sounds—no fuzz on the edges of words—no thin, squeaky, distorted tones.

Instead, EVERY tone is clean-cut, separate and distinct from every other tone—soft, rich, round, full, mellow tones—a surprising volume of REAL MUSIC to which it is a delightful pleasure to listen. Price \$7.00 each.

Karas Electric Company 599 N. Rockwell St., Chicago

Rubicon Kits Cut Cost

Go the coming summer weather one better by building a Super—at a saving. Write for the free folder on RUBICON Kits. It tells just what's needed. Check off the parts you have. Then from your dealer, or from us direct, get the Kit that fits your needs.

Postcard brings free folder.

RUBICON COMPANY
 29 N. Sixth St. Philadelphia, Pa.



Kits to build 8 or 9 tube sets. \$23.50 to \$138.50

DURHAM Grid Leaks

Used by Eagle, Howard, Thompson, Zenith and others. Fit all sets. Sold on guarantee.

50c Metallized Fixed Leaks
18 sizes; under 1/4 meg., 75c; over 1/4 meg., 50c.

75c Glass Sealed Variable Leaks
3 sizes fit all sets; 75c each for 1/10, 5 and 10 megs.

At dealers or postpaid

DURHAM & COMPANY, Inc.
1936 Market Street - Philadelphia, Pa.

Patented!

This is the patented automatic plug—the Pacent Autoplug.

It's shock-proof, and the red and blue buttons indicate polarity. Genuine bakelite shell. Price, 75c. Write for free catalog of the entire Pacent line.

Pacent Electric Co., Inc.
91-7th Ave., New York

Pacent RADIO ESSENTIALS

DON'T IMPROVISE — PACENTIZE!

"Long Distance"

No better tube made for getting distant stations than the SCHICKERLING Tube noises and distortion eliminated by patented stabilizing plates.

\$3

Model S-4000
5 volt, Standard Base, 1/4 amp. Detector-Amplifier
10-Day guarantee

Mail orders filled promptly

SCHICKERLING PRODUCTS CORP.
401-407 Mulberry Street
Newark, N. J.

Write for list of other models

Valley Battery Chargers

Price \$18.50
Complete with Cord, Battery Leads and Clips.

NO BULBS. NO LIQUIDS.
Correct 6-ampere charging rate. Quiet. Safe. Thousands in satisfactory operation.

VALLEY ELECTRIC CO.,
3157 S. Kingshighway, St. Louis, Mo.

ZENITH RADIO

Tunes straight through the locals, gets distance, brings in more stations—clearly and with volume—in a given length of time than any other set. Direct comparisons invited. Zenith receiving sets cost more, but they do more. —The exclusive choice of MacMillan for his North Polar Expedition.

Zenith Radio Corporation
332 S. Michigan Avenue, Chicago

Mailing Lists

WILL help you increase sales. Send for FREE catalog giving counts and prices on thousands of classified names of your prospective customers, including new lists covering the radio field.

99% Guaranteed by 5c each refund of

ROSS-Gould Co. 325 N. 10th St. St. Louis

radio program with as much care as his co-worker, Oscar, balances the menus at the Waldorf. A typical program includes dance music, such as "Bye, Bye, Baby" and "Oh, Katharina," vocal solos such as "A Kiss From You," "Cradle Song," "I Wonder Where We've Met Before," all sung by "The Man in the Silver Mask," and, not to forget our Mr. Carlin, you must hear at least one tango during the evening such as "Spain," so that he can play the castanets.

Mr. Carlin announces very humorously throughout the hour, and so many letters have come to him in recognition of his entertainment that he has opened a mock castanet school, and for a few minutes each evening he gives so-called instruction in the playing of this entertaining instrument.

The real excitement of the evening develops when "The Man in the Silver Mask" sings his opening feature. "Who is he? Is he John McCormack, Chauncey Olcott, Fiske O'Hara?" "Has he had a concert career?" "Is he from the Metropolitan?" Letters pour in by the thousands beseeching his name, hazarding guesses as to his identity, but the studio force at WEAf preserves a strict, heartless silence.

He is, we learn, an Irish lyric tenor, of the real Irish type. He may sing "Mother Machree" with justice, for we learn that not so long ago he had aspirations to become a boxer. He fought several amateur bouts until his mother learned of it, then she begged him to decide between the widely different careers of boxing and singing, laying her own emphasis upon the latter, so the son gave up the boxing.

He is a well-known gentleman, this "Man in the Silver Mask," for during the World War, in which he served as an ammunition runner, he won the praise of King Albert of Belgium and Sir Douglas Haig, Commander-in-Chief of the British Army, when he sang for a dinner given in their honor in France. Chautauqua audiences have listened to him. In your home you undoubtedly have records which he has made for one of the leading companies. All we can do is to show you his picture, masked like a bandit who has stolen his way into your hearts. You may guess who he is if you can.

Some estimate of how tremendously popular the Silvertown Cord Orchestra has been may be gained from the fact that when they started broadcasting the company offered a crossword puzzle book to any one writing for it. The books incidentally contained information about Goodrich Tires, which is one of the several radio tie-ups with merchandising information.

The company started out with 25,000 copies on hand; almost immediately the order had to be increased to 100,000, and at the present time some 300,000 of these books have been distributed.

"The Man in the Silver Mask" has received over 2000 letters in one week. Letters come from all over the country, for we have here one of the largest tie-ups used by any feature at WEAf.

Engagements have been offered the orchestra in all parts of the country. If arrangements could be made whereby their broadcasting could be continued as they travel they might tour from New England to Florida and from New York to San Francisco. The Goodrich Company feels that the orchestra has more than fulfilled the purpose for which it was engaged, which is, of course, the bringing of an hour of happiness into the homes of the American people and developing a spirit of good will between the consumer and the manufacturer.

Popularity of Summer Radio Is Increasing



The use of Kellogg transformers in your set will prove a delight in clear, powerful reception.

Kellogg radio frequency transformers are of the low-loss, high-efficiency type. No "dope" to hold windings in place. Minimum amount of insulating material. No. 603 for selective tuning. No. 602 when exceptional selectivity is not desired.

Kellogg audio frequency transformers are built right for the kind of service you expect. They amplify the highest or lowest tones with absolute fidelity. Built in 3 and 4 1/2 to 1 ratios.

Kellogg transformers are on sale at all radio dealers. Their use with Kellogg low-loss condensers will give you an ideal tuning and amplifying combination for your set, with results that will be most pleasing.

KELLOGG SWITCHBOARD & SUPPLY CO.

Chicago, Illinois



I will buy for you

any apparatus mentioned in this magazine and send it, carefully packed, direct to your door, plus only parcel post and insurance.

I MAKE NO CHARGE FOR THIS SERVICE!
It is conducted in co-operation with Mr. H. M. Neely, and is for the convenience of his readers.

WHY NOT BUY A CERTAINTY? Schickerling Tubes

More Distance—Less Noise. The 4th Element Grounds Eddy Currents—That's Why.

S-4000—1/4 Amp., Std. Base.	\$3.00
S-600—1-10 Amp., 199 Base.	3.00
S-1600—16-100 Amp., Std. Base.	4.00
S-700—1/4 Amp., Power Tube, Std. Base.	7.00

I Have Them in Stock. Try a Set and Note the Difference

AT LAST! I have found a B-Limitator, after long and severe tests, I can put my approval and guarantee upon.

It is the **TIMMONS B-LIMITATOR**

If you have 110-volt, 60-cycle A. C. in your house and operate a set with five or less tubes, take my advice and buy a Timmons B-Limitator. It has my personal endorsement and I know it will improve any set. Costs less than B Batteries.

Timmons B-Limitator Kit, with Tube \$20.00
Put it together yourself in 40 minutes. Add postage for 9 pounds

Timmons B-Limitator, with Tube \$35.00
Completely assembled in metal box. Add postage for 10 pounds

Write Me for Information on the latest SUPER-HETERODYNE development. Will be offered to the public in the Fall.

E. M. CLARKE
1523 Chestnut St., Phila.
Phone Rittenhouse 8918

RADIO BOOK only \$1

514 PAGES

Just off the press! The greatest book on radio ever written. Price only \$1. Filled with sound, practical, tested information for every Radio fan, from beginner to hard-boiled owl. Written, compiled and edited by men of national reputation. Every page tells you something useful—and there are 514 pages. Mail \$1 today and get this I. C. S. Radio Handbook before you spend another cent on parts. Money back if not satisfied.

Box 8266E, Scranton, Penna.
International Correspondence Schools

Made to order especially for radio

Radion is the material with highest insulating characteristics proved by tests. It keeps down leakage and losses. Send 10 cents for helpful booklet, "Building Your Own Set." American Hard Rubber Co., Dept. N-8, 11 Mercer St., New York City.

RADION

The Supreme Insulation

Panels, Dials, Sockets, Binding Post Panels, etc.



A B-Limitator Kit for \$20.00



enables you to use your house current in place of B batteries

B-Limitator Kits are made up the same parts that are used in the Timmons B-Limitator, now so enthusiastically endorsed by radio authorities and set users. Anyone can assemble a B-Limitator Kit. Complete instructions come packed with each one. Special B-Limitator tube is included, at the price of \$20.

The kit can be installed inside a radio cabinet or on a separate panel and baseboard. Detector control gives voltages from 0 to 45—amplifier control from 0 to 120, with all in-between voltages. Operates on alternating current, 110 volt—60 cycle.

Your dealer carries or can obtain for you both B-Limitators and B-Limitator Kits. However, if he cannot supply you, write us direct and mention his name.

We will also send you a folder containing many letters from B-Limitator users.

TIMMONS RADIO PRODUCTS CORPORATION
Germantown, Philadelphia

Timmons B-Limitator. Price, \$35— with special tube

TIMMONS RADIO PRODUCTS



List of Leading
Articles Which
Appeared in

RADIO IN THE HOME

From April,
1924, to
April, 1925

(Excluding September, 1924)

PRICE FOR COMPLETE SET OF TWELVE ISSUES, POSTPAID
\$1.00

INDEX TO THE BEST IN RADIO CIRCUITS, RECEIVERS AND APPARATUS

	Page No.		Page No.
APRIL, 1924			
Grimes Designs a Portable Inverse Duplex.....	8	Notes on the Grimes-Briggs Neutrodyne.....	34
Three Tubes in a Corona Case.....	10	How Far Will This Set Receive?.....	36
The Langbein and Kaufman Circuit.....	14	NOVEMBER, 1924	
Goodreau's Spiderweb Portable Set.....	17	Our Most Successful Hook-Up.....	6
Lightning a Danger? Not a Bit!.....	19	Now's the Time to Overhaul.....	12
Don't Shield—Wire Up Correctly.....	20	How the Harkness Reflex Can Be Changed to the New Harkness Counterflex.....	14
You Can Suppress That Interference.....	24	Inverse Duplexing the Pfanstiehl System.....	18
How to Charge Your Storage B's.....	34	How Much of a Nuisance Are You?.....	25
Answers to Questions on the Super-Heterodyne.....	36	DECEMBER, 1924	
More About the "Levin Singletrol".....	41	Flewelling's New Circuit.....	11
MAY, 1924			
The Story of Reflex and Radio Frequency.....	9	The Two-Tube Harkness Counterflex.....	16
The Aircore Super-Heterodyne.....	11	3XP-Style Wire-Ups, Harkness Counterflex.....	18
A Raw Amateur's Experiences With the Super-Heterodyne.....	18	Reflexing the Oscillating Set.....	21
A Favorite Circuit Simplified (Goodreau Circuit).....	24	A Favorite Circuit Simplified (Goodreau).....	25
JUNE, 1924			
Simple Hook-Up for Testing Tubes.....	6	Further Notes on the Inverse Duplex Neutrodyne.....	54
Harkness Tells About His Reflex.....	9	JANUARY, 1925	
The New Grimes 3XP Inverse-Duplex.....	12	The Question of Dry Cell Tubes.....	6
Re-Radiating Receivers.....	16	Flewelling's Circuit.....	13
"Factory" Refinements in Home-Built Sets.....	17	The Counterflex Simplified.....	19
How to Become a DX Sharpshooter.....	19	The Beginner's Best Bet.....	26
A Novel Loop Tuner.....	25	Grimes Takes the Hum Out of His 3 XP.....	30
JULY, 1924			
Harkness Writes About Self-Oscillation.....	13	Notes on Our Inverse Duplex (Super-Coil).....	36
Trouble Shooting in the Grimes 3XP.....	15	FEBRUARY, 1925	
Static Causes.....	20	Story of the Radio Ray.....	11
"Factory" Refinements in Home-Built Sets.....	21	Grimes Final 3XP.....	12
Levin's New Coil Makes a DX Portable.....	24	Harkness Reflex and Counterflex Circuits.....	19
R. F. and the Goodreau Split Variometer.....	25	Reception With the Flewelling Circuit.....	24
Tube-Testing Outfit for Dealers.....	31	Can You Explain Radio to Your Friends?.....	26
What Size Grid Leak Shall I Use?.....	43	For the Inverse Duplex Experimenter.....	42
AUGUST, 1924			
The Neutrodyne—Installation and Operation.....	9	For the Advanced Student.....	45
Audio-Frequency Amplifiers.....	11	MARCH, 1925	
Neutroformers in the Grimes 3XP.....	13	Let's Talk About Tubes.....	7
Correct Aerial Insulation.....	16	How to Build a Commercial Counterflex.....	10
The Greene "Selector".....	18	A 100 Per Cent Antenna.....	15
A Tube That Eliminates the "A" Battery.....	34	A DX Getter Easy to Build.....	20
OCTOBER, 1924			
On Resistance Coupled Amplification.....	6	Radio Frequency and the Flewelling Circuit.....	24
The New Harkness Counterflex Circuit.....	11	For the Advanced Student.....	26
3XP-Style Wire-Ups of the New Harkness Counterflex.....	14	APRIL, 1925	
New Sets of this Season.....	18	The 3XP Browning Drake.....	9
The Neutrodyne.....	24	The Question of "Low Loss" and "Bunk".....	15
New 110-Volt Tube with Replaceable Filament.....	25	An Humble Thought or Two About "Low Loss".....	16
Tubes—A Survey and a Forecast.....	26	How to Gain Quality.....	18
		Counterflex Symptoms.....	20
		What Colors Does Your Set Receive?.....	24
		For the Advanced Student.....	39
		Bird's Eye View of the "Low Loss" Idea.....	41

Send your order in at once. Our supply is fast becoming exhausted. All other issues except those listed above are out of print. Single copies, 10c each

THE RADIO KINDERGARTEN SERIES—The above issues contain eight lessons on the fundamentals of radio. These lessons are written in simple language and are designed to acquaint the beginner in radio with the leading phases of radio reception.

BROADCASTING STATIONS—The following stations were described and illustrated in the issues listed above: WBAP, WDAR, WJAX, WJAZ, WCBD, WGN, WLS, WLAG, KFNF, WFAF, WTAM, KSAC, WEEL, WTAT, WSAL, KLZ, WMAQ.

The form below is for your convenience in ordering.

RADIO IN THE HOME,
608 Chestnut St., Phila., Pa.

Date

Enclosed find \$1.00 (\$2.00 foreign; \$1.25 Canada), for which please send me postpaid 12 consecutive issues (excluding Sept., 1924), of RADIO IN THE HOME, from April, 1924, to April, 1925, Inclusive.

Name Street

City and State.....